

CONTENTS

PRODUCTS FOR INDUSTRIAL APPLICATIONS

Cable Glands for Industrial Applications

Plastic Cable Glands

• Standard Cable Glands	4 - 7
• Snap-in Cable Glands	8 - 9
• Cable Protection Glands	10 - 13
• Elbow Cable Glands	14
• RJ-45 Cable Glands	15
• Quick-Fit Cable Glands	16 - 17

Metal Cable Glands

• Standard Cable Glands, Brass	20 - 23
• Standard Cable Glands, Stainless Steel	24 - 27
• Snap-in Cable Glands, Brass	28 - 29
• Compression Type Cable Glands, Brass	30 - 31
• Cable Protection Glands, Brass	32
• Neoglands, Brass	33
• Double Seal Cable Glands, Compact Design, Brass	34
• RJ-45 Cable Glands, Brass	35
• Armoured Cable Glands	36 - 37
• EMC Cable Glands	
• EMC 2 Cable Glands, Brass	42 - 45
• EMC 3 Cable Glands, Brass	46 - 49
• EMC 4 Cable Glands, Brass	50 - 53
• Snap-in Cable Glands, EMC 4, Brass	54 - 55
• Cable Protection Glands, EMC 2, Brass	56 - 57

Railway Cable Glands

• Octans Cable Glands for Railway Applications, Brass	60 - 61
• Standard Cable Glands for Railway Applications, Brass	62 - 63
• EMC 4 Cable Glands for Railway Applications, Brass	64 - 65
• Standard Cable Glands for Railway Applications, Polyamide	66 - 67

Ventilation and Drain Products

• Ventilation Cable Glands, Polyamide	70 - 71
• Ventilation Plugs, Polyamide	72 - 73
• Drain Plugs, Polyamide	74 - 75
• Ventilation Cable Glands, Brass	76 - 77
• Ventilation Plugs, Metal	78 - 79
• Drain Plugs, Brass	80 - 81

Hygienic Products

Hygienic Cable Glands

• Hygienic Cable Glands, Stainless Steel	86 - 87
• Hygienic Cable Glands, EMC, Stainless Steel	88 - 89

Hygienic Conduit Fittings

• Hygienic Conduit Fittings, Stainless Steel	90 - 91
--	---------

Conduit Fittings

• Rigid Conduit Fittings	96
• Straight Fittings	97
• Enclosure Couplers	98
• Flexible Fittings for Rigid Conduits	99
• Straight Couplers	100
• Conduit Unions	101
• Bend Couplers	

Liquidtight Flexible Conduit Fittings

• Straight Liquidtight Conduit Fittings, Male	102 - 103
• 45° Liquidtight Conduit Fittings, Male	104 - 105
• 90° Liquidtight Conduit Fittings, Male	106 - 107
• Straight Liquidtight Conduit Fittings, Female	108 - 109
• Straight Liquidtight Conduit Fittings, Cable Hose, Male	110 - 111
• Straight Swivel Fittings	112

Adaptors & Plugs

Plastic Plugs

• Round Plugs	116
• Hexagonal Plugs	117
• Modular Plugs	118

Metal Adaptors

• Enlargers, Brass	119
• Adaptors, Brass	120 - 121
• Reducers, Brass	122 - 123

Metal Plugs

• Hexagonal Plugs	124
• Round Plugs	125

PRODUCTS FOR HAZARDOUS APPLICATIONS

Mining Applications

Metal Products

Cable Glands for Armoured Cables

• Orion for Mining Applications	132 - 135
• Corona for Mining Applications	136 - 139
• Centaurus-A Barrier for Mining Applications	140 - 141

Cable Glands for Non-armoured Cables

• Crater for Mining Applications	144 - 147
• Centaurus-N Barrier for Mining Applications	148 - 149

Gas / Dust Applications

Metal Products

Cable Glands for Armoured Cables

• Orion Universal	152 - 155
• Orion Offshore	156 - 159
• Orion	160 - 163
• Orion Lead Sheathed	164 - 167
• Corona Universal	168 - 171
• Corona Offshore	172 - 175
• Corona	176 - 179
• Centaurus-A Barrier	180 - 181
• E-Vela	182 - 183

Cable Glands for Non-armoured Cables

• E-Octans	186 - 189
• E-Octans Flat	190 - 191
• Crater	192 - 193
• Centaurus-N Barrier	194 - 195

Ventilation and Drain Products

• Hydra, Ventilation Plugs	198 - 199
• Virgo, Drain Plugs	200 - 201

Fittings for Rigid Conduits with Non-armoured Cables

• E-Carina, Straight Conduit Fittings	204 - 207
• E-Carina Flat, Straight Conduit Fittings	208 - 211
• E-Cygnus, Swivel Conduit Fittings	212 - 215
• Phoenix, Multihole Swivel Conduit Fittings	216 - 217

Fittings for Flexible Conduits with Non-armoured Cables

• E-Hydrus	220 - 221
• E-Scorpius	222 - 223
• E-Lupus	224 - 225
• E-Corvus	226 - 227

Adaptors & Plugs

• Apus, Enlargers	230 - 233
• Grus, Reducers	234 - 237
• Aries, Couplers	238 - 241
• Pavo, Nipples	242 - 245
• Aquila Hexagonal, Plugs	246 - 247
• Aquila Round, Plugs	248 - 249

Plastic Products

Cable Glands for Non-armoured Circular Cables

• Lyra	252 - 253
• Hi-Lyra	254 - 257
• Vega	258 - 261

Cable Glands for Non-armoured Non-circular Cables

• Gemini	262 - 263
• Hi-Gemini	264 - 265

Plugs

• Draco	268 - 269
• Hi-Draco	270 - 271

ACCESSORIES

Seals & Dome Plugs

• Reducing Seals	274
• Double Seals	275
• Flat Cable Seals	276
• Dome Plugs For Industrial Applications	277
• Multihole Seals	278 - 279
• Cetus, Dome Plugs For Hazardous Applications	280 - 281

Gaskets

• Serrated Washers	282 - 283
--------------------	-----------

Serrated Washers

• Earth Tags	284
--------------	-----

Lock Nuts

Plastic Lock Nuts

• Lock Nuts, Polyamide, Flanged	286
• Lock Nuts, Polyamide, Without Flange	287

Metal Lock Nuts

• Lock Nuts, Metal	288 - 289
• Lock Nuts, EMC, Metal	290

Shrouds

• Shrouds for Orion Cable Glands	291
• Shrouds for E-Octans / E-Vela Cable Glands	291

APPENDIX

• Thread Diameters and Hole Sizes	294
• Strain Relief acc. to EN and acc. to UL	295
• IP Rating	296
• Type 4x Rating	297
• Assembly Instructions	298 - 301
• Product Number INDEX	302 - 303



Polyamide CABLE GLANDS for Industrial Applications



Glands

Standard Glands	4 - 7
Snap-In Glands	8 - 9
Cable Protection Glands	10 - 13
Elbow Glands	14
RJ-45 Glands	15
Quick Fitting Glands	16 - 17

Polyamide CABLE GLANDS for Industrial Applications







Standard Glands with Thread, Polyamide

Polyamide cable glands with lamellar clamping

- For standard industrial applications.
- Easy assembly.
- High quality strain relief and sealing, reliable performance for standard industrial applications.
- Up-to-date international approvals.

Technical Details

Material	Body, Cap	PA 6 (Polyamide 6)	
	Seal	CR (Chloroprene)	
Ingress Protection Rating	IP 68 - 5 Bar, 30 min		
	IP 66		
Flammability	V2 according to UL94		
Operating Temperature	Permanent		Intermittent
	-20 °C to +100 °C		-30 °C to +150 °C
Thread Type	<ul style="list-style-type: none"> • Metric EN 60423 • PG DIN 40430 • NPT ANSI B1.20.1 • Gas ISO 228 • Other thread types also available upon request. 		
Cable Type	Non armoured		
Accessories	<ul style="list-style-type: none"> • Lock nuts • Dome plugs • Reducing seals • Flat cable seals • Multihole seals • Gaskets (Washers) 		
	<ul style="list-style-type: none"> • Manufactured according to DIN EN 62444/50262. • We recommend the use of locknuts and gaskets to ensure IP rating for rough surfaces or through holes. • Accessories must be ordered separately. • Some approvals do not cover all sizes. • Other colours on request: RAL 5015 (blue) RAL 9003 (white) RAL 3020 (red) 		
Remarks			

Approvals	Certificate Number	Standards
	134171	DIN EN 62444
	115116_0_000	CSA C22.2
	E199260	UL514B CSA22.2 No 18.3-12 CSA22.2 No 94.2-15
		UL50E
TYPE 4X		
	SERCOVAM RES 107572	UL514B §8.26.7
	E-14046	EN62444

For more approvals: see our webpage.



Standard Glands with Thread, Polyamide

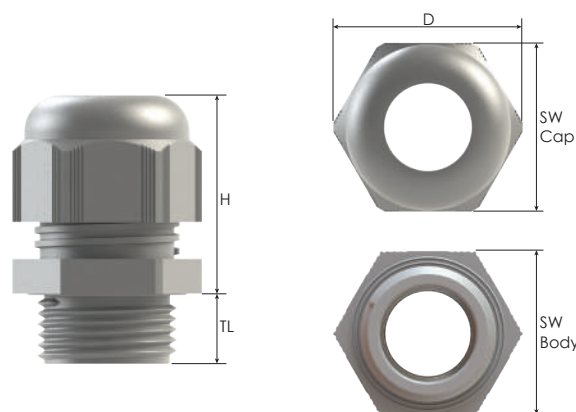

Thread Type METRIC acc. to EN 60423

Outer Thread Size (Male)	Clamping Range Ø min - max	Outer Thread Length	Spanner Width		Outer Ø	max. Height	Part Number			Minimum Order Quantity
			Cap	Body			RAL 7035 light grey	RAL 7001 grey	RAL 9005 black	
			mm	mm						
M12x1,5	2,0 - 5,0	8,0	15	15	17,0	25,3	BI-1S	BI-0S	BI-2S	4000
	2,0 - 5,0	10,0	15	15	17,0	25,3	BM-EN-1SMR	BM-EN-0SMR	BM-EN-2SMR	4000
	2,0 - 5,0	15,0	15	15	17,0	25,3	BM-EN-1SRL	BM-EN-0SRL	BM-EN-2SRL	4000
	3,0 - 6,5	8,0	15	15	17,0	25,3	BM-1S	BM-0S	BM-2S	4000
	3,0 - 6,5	10,0	15	15	17,0	25,3	BM-EN-1SM	BM-EN-0SM	BM-EN-2SM	4000
	3,0 - 6,5	15,0	15	15	17,0	25,3	BM-EN-1SL	BM-EN-0SL	BM-EN-2SL	4000
M16x1,5	2,0 - 6,0	8,0	19	19	21,7	27,4	BM-EN-11R	BM-EN-01R	BM-EN-21R	2000
	2,0 - 6,0	10,0	19	19	21,7	27,4	BM-EN-11MR	BM-EN-01MR	BM-EN-21MR	2000
	2,0 - 6,0	15,0	19	19	21,7	27,4	BM-EN-11LR	BM-EN-01LR	BM-EN-21LR	2000
	3,0 - 7,0	10,0	22	22	25,0	32,2	BI-11	BI-01	BI-21	1800
	3,0 - 7,0	15,0	22	22	25,0	32,2	BI-11L	BI-01L	BI-21L	1500
	4,0 - 8,0	8,0	19	19	21,7	27,4	BM-EN-11	BM-EN-01	BM-EN-21	2000
	4,0 - 8,0	10,0	19	19	21,7	27,4	BM-EN-11M	BM-EN-01M	BM-EN-21M	2000
	4,0 - 8,0	15,0	19	19	21,7	27,4	BM-EN-11L	BM-EN-01L	BM-EN-21L	2000
	5,0 - 10,0	10,0	22	22	25,0	32,2	BM-11	BM-01	BM-21	1800
	5,0 - 10,0	15,0	22	22	25,0	32,2	BM-11L	BM-01L	BM-21L	1500
M20x1,5	5,0 - 9,0	10,0	24	24	27,0	32,4	BI-12	BI-02	BI-22	1600
	5,0 - 9,0	15,0	24	24	27,0	32,4	BI-12L	BI-02L	BI-22L	1000
	6,0 - 12,0	10,0	24	24	27,0	32,4	BM-12	BM-02	BM-22	1600
	6,0 - 12,0	15,0	24	24	27,0	32,4	BM-12L	BM-02L	BM-22L	1000
	7,0 - 12,0	10,0	27	27	30,9	31,9	BI-13	BI-03	BI-23	1000
	7,0 - 12,0	15,0	27	27	30,9	31,9	BI-13L	BI-03L	BI-23L	850
	7,0 - 13,0	10,0	25	25	27,5	34,0	BM-EN-12S	BM-EN-02S	BM-EN-22S	1600
	10,0 - 14,0	10,0	27	27	30,9	31,9	BM-13	BM-03	BM-23	1000
	10,0 - 14,0	15,0	27	27	30,9	31,9	BM-13L	BM-03L	BM-23L	850
	9,0 - 13,0	8,0	29	29	32,5	37,7	BM-EN-13R	BM-EN-03R	BM-EN-23R	800
M25x1,5	9,0 - 13,0	15,0	29	29	32,5	37,7	BM-EN-13RL	BM-EN-03RL	BM-EN-23RL	800
	9,0 - 16,0	10,0	33	33	37,2	38,4	BI-15	BI-05	BI-25	600
	9,0 - 16,0	15,0	33	33	37,2	38,4	BI-15L	BI-05L	BI-25L	600
	11,0 - 17,0	8,0	29	29	32,5	37,7	BM-EN-13	BM-EN-03	BM-EN-23	800
	11,0 - 17,0	15,0	29	29	32,5	37,7	BM-EN-13L	BM-EN-03L	BM-EN-23L	800
	13,0 - 18,0	10,0	33	33	37,2	38,4	BM-15	BM-05	BM-25	600
	13,0 - 18,0	15,0	33	33	37,2	38,4	BM-15L	BM-05L	BM-25L	600
	11,0 - 15,0	10,0	36	36	41,0	42,3	BM-EN-14R	BM-EN-04R	BM-EN-24R	500
M32x1,5	11,0 - 15,0	15,0	36	36	41,0	42,3	BM-EN-14RL	BM-EN-04RL	BM-EN-24RL	500
	12,0 - 20,0	15,0	42	42	47,1	43,3	BI-17	BI-07	BI-27	400
	15,0 - 21,0	10,0	36	36	41,0	42,3	BM-EN-14	BM-EN-04	BM-EN-24	500
	15,0 - 21,0	15,0	36	36	41,0	42,3	BM-EN-14L	BM-EN-04L	BM-EN-24L	500
	18,0 - 25,0	15,0	42	42	47,1	43,3	BM-17	BM-07	BM-27	400
M40x1,5	16,0 - 23,0	10,0	46	46	52,4	47,4	BM-EN-15R	BM-EN-05R	BM-EN-25R	340
	16,0 - 23,0	18,0	46	46	52,4	47,4	BM-EN-15RL	BM-EN-05RL	BM-EN-25RL	340
	19,0 - 28,0	10,0	46	46	52,4	47,4	BM-EN-15	BM-EN-05	BM-EN-25	340
	19,0 - 28,0	18,0	46	46	52,4	47,4	BM-EN-15L	BM-EN-05L	BM-EN-25L	340
	20,0 - 26,0	18,0	53	53	59,6	52,4	BI-18	BI-08	BI-28	200
M50x1,5	22,0 - 32,0	18,0	53	53	59,6	52,4	BM-18	BM-08	BM-28	200
	25,0 - 31,0	18,0	60	60	67,8	54,8	BI-19	BI-09	BI-29	160
M63x1,5	30,0 - 38,0	18,0	60	60	67,8	54,8	BM-19	BM-09	BM-29	160
	29,0 - 35,0	18,0	65	65	72,4	54,9	BI-20	BI-10	BI-30	150
M75x2,0	34,0 - 44,0	18,0	65	65	72,4	54,9	BM-20	BM-10	BM-30	150
	48,0 - 55,0	25,0	75	80	89,0	55,0	BM-B12	BM-B02	BM-B22	80





Standard Glands with Thread, Polyamide

Polyamide cable glands with lamellar clamping

- For standard industrial applications.
- Easy assembly.
- High quality strain relief and sealing, reliable performance for standard industrial applications.
- Up-to-date international approvals.

Technical Details

Material	Body, Cap	PA 6 (Polyamide 6)	
	Seal	CR (Chloroprene)	
Ingress Protection Rating	IP 68 - 5 Bar, 30 min		
	IP 66		
Flammability	V2 according to UL94		
Operating Temperature	Permanent		Intermittent
	-20 °C to +100 °C		-30 °C to +150 °C
Thread Type	<ul style="list-style-type: none"> • Metric EN 60423 • PG DIN 40430 • NPT ANSI B1.20.1 • Gas ISO 228 • Other thread types also available upon request. 		
Cable Type	Non armoured		
Accessories	<ul style="list-style-type: none"> • Lock nuts • Dome plugs • Reducing seals • Flat cable seals • Multihole seals • Gaskets (Washers) 		
	<ul style="list-style-type: none"> • Manufactured according to DIN EN 62444/50262. • We recommend the use of locknuts and gaskets to ensure IP rating for rough surfaces or through holes. • Accessories must be ordered separately. • Some approvals do not cover all sizes. • Other colours on request: RAL 5015 (blue) RAL 9003 (white) RAL 3020 (red) 		
Remarks			

Approvals	Certificate Number	Standards
	134171	DIN EN 62444
	115116_0_000	CSA C22.2
	E199260	UL514B CSA22.2 No 18.3-12 CSA22.2 No 94.2-15
		UL50E
TYPE 4X		
	SERCOVAM RES 107572	UL514B §8.26.7
	E-14046	EN62444

For more approvals: see our webpage.



Standard Glands with Thread, Polyamide

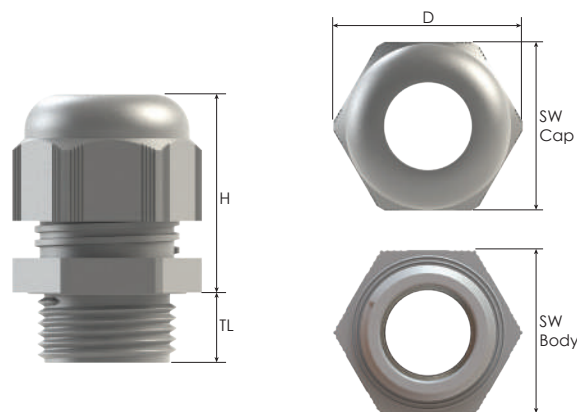

Thread Type NPT acc. to ANSI B1.20.1

Outer Thread Size (Male)	Clamping Range Ø min-max mm	Outer Thread Length TL mm	Spanner Width		Outer Ø D mm	max. Height H mm	Part Number			Minimum Order Quantity
			Cap SW Cap mm	Body SW Body mm			RAL 7035 light grey	RAL 7001 grey	RAL 9005 black	
NPT 3/8"	3,0 - 7,0	15,0	22	22	25,0	32,2	BSPA-11R	BSPA-01R	BSPA-21R	1500
	5,0 - 10,0	15,0	22	22	25,0	32,2	BSPA-11	BSPA-01	BSPA-21	1500
NPT 1/2"	5,0 - 9,0	15,0	24	24	27,0	32,4	BSPB-12R	BSPB-02R	BSPB-22R	1000
	6,0 - 12,0	15,0	24	24	27,0	32,4	BSPB-12	BSPB-02	BSPB-22	1000
	7,0 - 12,0	15,0	27	27	30,9	31,9	BSPC-12R	BSPC-02R	BSPC-22R	850
	10,0 - 14,0	15,0	27	27	30,9	31,9	BSPC-12	BSPC-02	BSPC-22	850
NPT 3/4"	9,0 - 16,0	15,0	33	33	37,2	38,4	BSPD-13R	BSPD-03R	BSPD-23R	600
	13,0 - 18,0	15,0	33	33	37,2	38,4	BSPD-13	BSPD-03	BSPD-23	600
NPT 1"	12,0 - 20,0	18,0	42	42	47,1	43,3	BSP-14R	BSP-04R	BSP-24R	400
	18,0 - 25,0	18,0	42	42	47,1	43,3	BSP-14	BSP-04	BSP-24	400

Thread Type PG acc. to DIN 40430

Outer Thread Size (Male)	Clamping Range Ø min-max mm	Outer Thread Length TL mm	Spanner Width		Outer Ø D mm	max. Height H mm	Part Number			Minimum Order Quantity
			Cap SW Cap mm	Body SW Body mm			RAL 7035 light grey	RAL 7001 grey	RAL 9005 black	
PG 7	2,0 - 5,0	8,0	15	15	17,0	25,3	BSR-11	BSR-01	BSR-21	4000
	3,0 - 6,5	8,0	15	15	17,0	25,3	BS-11	BS-01	BS-21	4000
PG 9	2,0 - 6,0	8,0	19	19	21,7	27,4	BSR-12	BSR-02	BSR-22	2000
	4,0 - 8,0	8,0	19	19	21,7	27,4	BS-12	BS-02	BS-22	2000
PG 11	3,0 - 7,0	8,0	22	22	25,0	32,2	BSR-13	BSR-03	BSR-23	1800
	5,0 - 10,0	8,0	22	22	25,0	32,2	BS-13	BS-03	BS-23	1800
PG 13,5	5,0 - 9,0	10,0	24	24	27,0	32,4	BSR-14	BSR-04	BSR-24	1600
	6,0 - 12,0	10,0	24	24	27,0	32,4	BS-14	BS-04	BS-24	1600
PG 16	7,0 - 12,0	10,0	27	27	30,9	31,9	BSR-15	BSR-05	BSR-25	1000
	10,0 - 14,0	10,0	27	27	30,9	31,9	BS-15	BS-05	BS-25	1000
PG 21	9,0 - 16,0	11,0	33	33	37,2	38,4	BSR-16	BSR-06	BSR-26	600
	13,0 - 18,0	11,0	33	33	37,2	38,4	BS-16	BS-06	BS-26	600
PG 29	12,0 - 20,0	11,0	42	42	47,1	43,3	BSR-17	BSR-07	BSR-27	400
	18,0 - 25,0	11,0	42	42	47,1	43,3	BS-17	BS-07	BS-27	400
PG 36	20,0 - 26,0	13,0	53	53	59,6	52,4	BSR-18	BSR-08	BSR-28	200
	22,0 - 32,0	13,0	53	53	59,6	52,4	BS-18	BS-08	BS-28	200
PG 42	25,0 - 31,0	13,0	60	60	67,8	54,8	BSR-19	BSR-09	BSR-29	160
	30,0 - 38,0	13,0	60	60	67,8	54,8	BS-19	BS-09	BS-29	160
PG 48	29,0 - 35,0	14,0	65	65	72,4	54,9	BSR-20	BSR-10	BSR-30	150
	34,0 - 44,0	14,0	65	65	72,4	54,9	BS-20	BS-10	BS-30	150

Thread Type G acc. to G ISO 228

Outer Thread Size (Male)	Clamping Range Ø min-max mm	Outer Thread Length TL mm	Spanner Width		Outer Ø D mm	max. Height H mm	Part Number			Minimum Order Quantity
			Cap SW Cap mm	Body SW Body mm			RAL 7035 light grey	RAL 7001 grey	RAL 9005 black	
G 1/4"	2,0 - 5,0	10,0	15	15	17,0	25,3	BPFR-1S	BPFR-0S	BPFR-2S	4000
	3,0 - 6,5	10,0	15	15	17,0	25,3	BPF-1S	BPF-0S	BPF-2S	4000
G 3/8"	3,0 - 7,0	11,0	22	22	25,0	32,2	BPFR-11	BPFR-01	BPFR-21	1800
	5,0 - 10,0	11,0	22	22	25,0	32,2	BPF-11	BPF-01	BPF-21	1800
G 1/2"	5,0 - 9,0	10,0	24	24	27,0	32,4	BPFR-12	BPFR-02	BPFR-22	1600
	6,0 - 12,0	10,0	24	24	27,0	32,4	BPF-12	BPF-02	BPF-22	1600
	7,0 - 12,0	11,0	27	27	30,9	31,9	BPFR-13	BPFR-03	BPFR-23	1000
	10,0 - 14,0	11,0	27	27	30,9	31,9	BPF-13	BPF-03	BPF-23	1000
G 3/4"	9,0 - 16,0	12,0	33	33	37,2	38,4	BPFR-14	BPFR-04	BPFR-24	600
	13,0 - 18,0	12,0	33	33	37,2	38,4	BPF-14	BPF-04	BPF-24	600
G 1"	12,0 - 20,0	13,0	42	42	47,1	43,3	BPFR-15	BPFR-05	BPFR-25	400
	18,0 - 25,0	13,0	42	42	47,1	43,3	BPF-15	BPF-05	BPF-25	400





Snap-In Glands without Thread, Polyamide

Polyamide cable glands, without thread

- Easy assembly; push cable gland and turn body clockwise.
- For wall thickness 0,5 mm to 4,0 mm.
- High quality strain relief and sealing, reliable performance for standard industrial applications.
- Easy disassembly (with separate tool).

Technical Details

Material	Body, Cap	PA 6 (Polyamide 6)	
	Gasket	CR (Chloroprene)	
	Seal	CR (Chloroprene)	
Ingress Protection Rating	IP 68 - 5 Bar, 30 min IP 66		
Flammability	V2 according to UL94		
Operating Temperature	Permanent	-20 °C to +100 °C	Intermittent
			-30 °C to +150 °C
Cable Type	Non armoured		
Accessories	<ul style="list-style-type: none"> • Dome plugs • Reducing seals • Flat cable seals • Multihole seals • Disassembly tools (one piece included per Minimum Order Quantity) 		
	<ul style="list-style-type: none"> • Different Seal types available. • Manufactured according to DIN EN 62444/50262. • Accessories must be ordered separately. • Some approvals do not cover all sizes. • Other colours on request: RAL 5015 (blue) RAL 9003 (white) RAL 3020 (red) 		
Remarks			

Approvals	Certificate Number	Standards
	134171	DIN EN 62444
	115116_0_000	CSA C22.2
	E199260	UL514B CSA22.2 No 18.3-12 CSA22.2 No 94.2-15
TYPE 4X		UL50E
	SERCOVAM RES 107572	UL514B §8.26.7
	E-14046	EN62444

For more approvals: see our webpage.

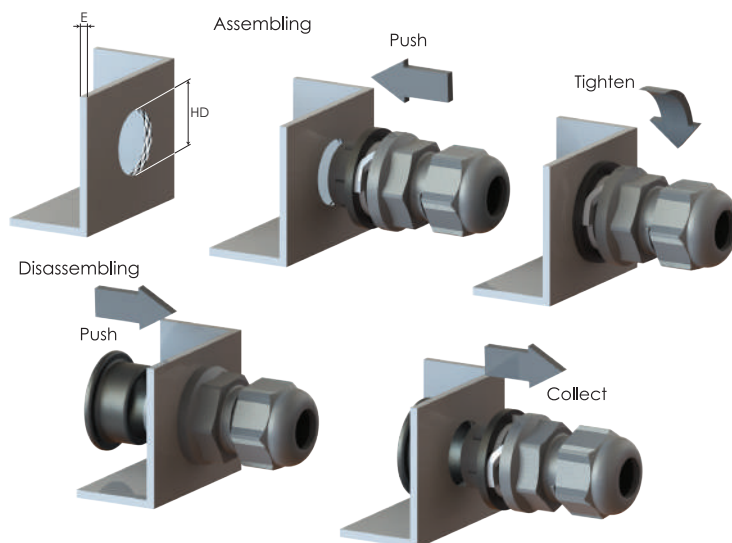
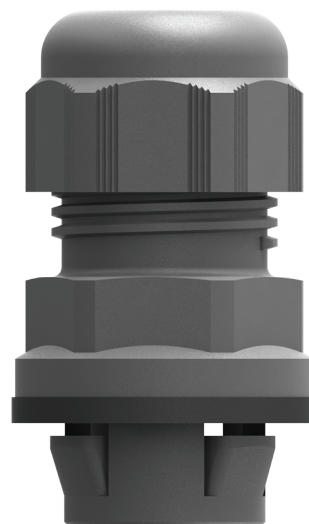

Snap-In Glands without Thread, Polyamide

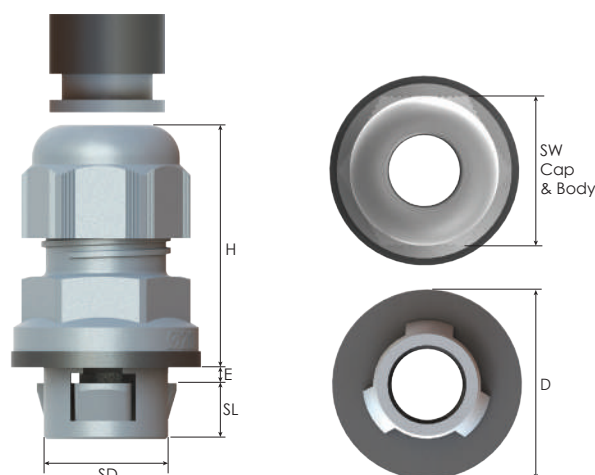

wall thickness (E) : 0,5 - 4,0 mm

Snap Size	Clamping Range		Snap Length		Wall Hole Ø	Spanner Width		Outer Ø	max.Height	Part Number			Minimum Order Quantity
	Ø min-max mm	Seal Type	SL mm	SD mm		HD mm	SW Cap mm			SW Body mm	D mm	H mm	
16	3,0 - 10,0	Double	9,0	15,9	16,2 - 16,4	22	22	26,5	44,5	BMOS-DS-11	BMOS-DS-01	BMOS-DS-21	1000
	5,0 - 10,0	Single	9,0	15,9	16,2 - 16,4	22	22	26,5	44,5	BMOS-11	BMOS-01	BMOS-21	1000
20	5,0 - 12,0	Double	9,0	19,9	20,2 - 20,4	24	24	30,3	43,5	BMOS-DS-12	BMOS-DS-02	BMOS-DS-22	1000
	3,0 - 13,0	Double	9,0	19,9	20,2 - 20,4	25	25	30,3	43,5	BMOS-EU-DS-12	BMOS-EU-DS-02	BMOS-EU-DS-22	1000
	6,0 - 12,0	Single	9,0	19,9	20,2 - 20,4	24	24	30,3	43,5	BMOS-12	BMOS-02	BMOS-22	1000
	7,0 - 13,0	Single	9,0	19,9	20,2 - 20,4	25	25	30,3	43,5	BMOS-EU-12	BMOS-EU-02	BMOS-EU-22	1000
25	8,0 - 17,0	Double	9,0	24,9	25,2 - 25,4	29	29	36,3	45,5	BMOS-EU-DS-13	BMOS-EU-DS-03	BMOS-EU-DS-23	500
	11,0 - 17,0	Single	9,0	24,9	25,2 - 25,4	29	29	36,3	45,5	BMOS-EU-13	BMOS-EU-03	BMOS-EU-23	500
32	11,0 - 21,0	Double	9,0	31,9	32,2 - 32,4	36	36	43,2	51,5	BMOS-EU-DS-14	BMOS-EU-DS-04	BMOS-EU-DS-24	500
	15,0 - 21,0	Single	9,0	31,9	32,2 - 32,4	36	36	43,2	51,5	BMOS-EU-14	BMOS-EU-04	BMOS-EU-24	500
40	16,0 - 28,0	Double	13,2	39,9	40,2 - 40,4	46	46	55,2	58,0	BMOS-EU-DS-15	BMOS-EU-DS-05	BMOS-EU-DS-25	250
	19,0 - 28,0	Single	13,2	39,9	40,2 - 40,4	46	46	55,2	58,0	BMOS-EU-15	BMOS-EU-05	BMOS-EU-25	250

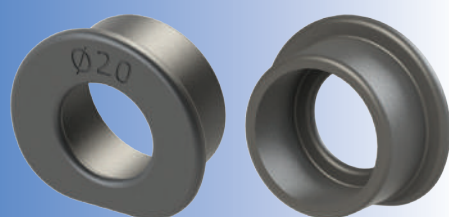

Tool to disassemble Snap-In Glands

Technical Details

Material Plastic

For Gland Size	Inner Ø	Height	Part Number
	ID mm	h mm	
16	16,0	13,0	BEX-16
20	20,0	13,0	BEX-20
25	25,0	13,0	BEX-25
32	32,0	13,0	BEX-32
40	40,0	15,5	BEX-40





Cable Protection Glands Polyamide

Cable protection glands with lamellar clamping

- For cable bending protection.
- Easy assembly.
- High quality strain relief and sealing, reliable performance for standard industrial applications.
- Up-to-date international approvals.

Technical Details

Material	Body, Cap	PA 6 (Polyamide 6)
	Seal	CR (Chloroprene)
Ingress Protection Rating	IP 68 - 5 Bar, 30 min IP 66	
Flammability	V2 according to UL94	
Operating Temperature	Permanent	-20 °C to +100 °C
	Intermittent	-30 °C to +150 °C
Thread Type	<ul style="list-style-type: none"> • Metric EN 60423 • PG DIN 40430 • NPT ANSI B1.20.1 • Gas ISO 228 • Other thread types also available upon request. 	
Cable Type	Non armoured	
Accessories	<ul style="list-style-type: none"> • Lock nuts • Reducing seals • Flat cable seals • Multihole seals • Gaskets (Washers) 	
Remarks	<ul style="list-style-type: none"> • Different Seal types available. • Manufactured according to DIN EN 62444/50262. • All accessories must be ordered separately. • We recommend the use of lock nuts and gaskets to ensure IP rating for rough surfaces or through holes. • Some approvals do not cover all sizes. Other colours on request: <ul style="list-style-type: none"> • RAL 5015 (blue) • RAL 9003 (white) • RAL 3020 (red) 	

Approvals	Certificate Number	Standards
	134171	DIN EN 62444
	115116_0_000	CSA C22.2
	E199260	UL514B CSA22.2 No 18.3-12 CSA22.2 No 94.2-15
TYPE 4X		UL50E
	SERCOVAM RES 107572	UL514B §8.26.7
	E-14046	EN62444

For more approvals: see our webpage.

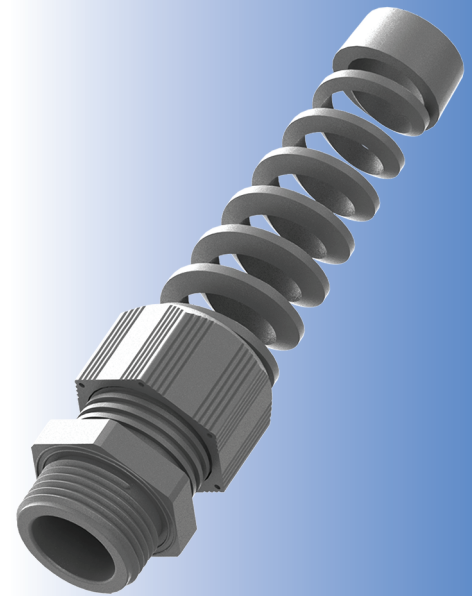

Cable Protection Glands Polyamide

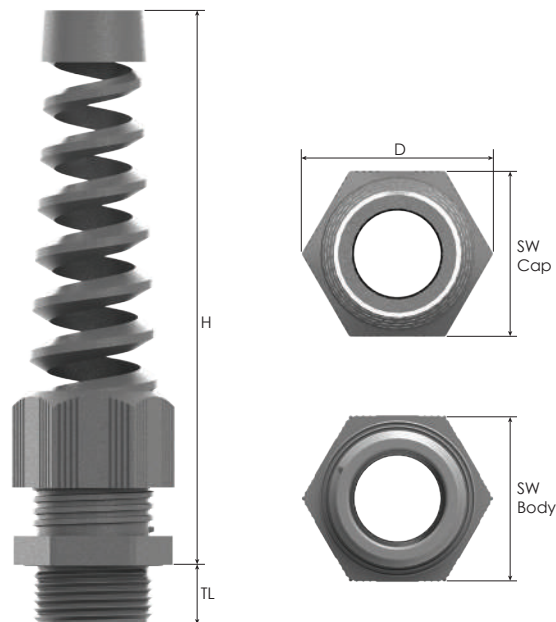

Thread Type METRIC acc. to EN 60423										
Outer Thread Size (Male)	Clamping Range Ø min-max mm	Outer Thread Length TL mm	Spanner Width		Outer Ø D mm	max. Height H mm	Part Number			Minimum Order Quantity
			Cap SW Cap mm	Body SW Body mm			RAL 7035 light grey	RAL 7001 grey	RAL 9005 black	
M12x1,5	2,0 - 5,0	8,0	15	15	16,6	58,0	BISP-1S	BISP-0S	BISP-2S	2000
	2,0 - 5,0	10,0	15	15	16,6	58,0	BISP-1SM	BISP-0SM	BISP-2SM	2000
	2,0 - 5,0	15,0	15	15	16,6	58,0	BISP-1SL	BISP-0SL	BISP-2SL	2000
	3,0 - 6,5	8,0	15	15	16,6	58,0	BMSP-1S	BMSP-0S	BMSP-2S	2000
	3,0 - 6,5	10,0	15	15	16,6	58,0	BMSP-1SM	BMSP-0SM	BMSP-2SM	2000
	3,0 - 6,5	15,0	15	15	16,6	58,0	BMSP-1SL	BMSP-0SL	BMSP-2SL	2000
M16x1,5	3,0 - 7,0	10,0	22	22	25,1	83,2	BISP-11	BISP-01	BISP-21	1000
	3,0 - 7,0	15,0	22	22	25,1	83,2	BISP-11L	BISP-01L	BISP-21L	1000
	5,0 - 10,0	10,0	22	22	25,1	83,2	BMSP-11	BMSP-01	BMSP-21	1000
	5,0 - 10,0	15,0	22	22	25,1	83,2	BMSP-11L	BMSP-01L	BMSP-21L	1000
M20x1,5	5,0 - 9,0	10,0	24	24	27,6	96,5	BISP-12	BISP-02	BISP-22	750
	5,0 - 9,0	15,0	24	24	27,6	96,5	BISP-12L	BISP-02L	BISP-22L	750
	6,0 - 12,0	10,0	24	24	27,6	96,5	BMSP-12	BMSP-02	BMSP-22	750
	6,0 - 12,0	15,0	24	24	27,6	96,5	BMSP-12L	BMSP-02L	BMSP-22L	750
	7,0 - 12,0	10,0	27	27	30,5	106,4	BISP-13	BISP-03	BISP-23	500
	7,0 - 12,0	15,0	27	27	30,5	106,4	BISP-14	BISP-04	BISP-24	250
	10,0 - 14,0	10,0	27	27	30,5	106,4	BMSP-13	BMSP-03	BMSP-23	500
	10,0 - 14,0	15,0	27	27	30,5	106,4	BMSP-14	BMSP-04	BMSP-24	250
M25x1,5	9,0 - 16,0	10,0	33	33	37,8	118,9	BISP-15	BISP-05	BISP-25	250
	9,0 - 16,0	15,0	33	33	37,8	118,9	BISP-16	BISP-06	BISP-26	250
	13,0 - 18,0	10,0	33	33	37,8	118,9	BMSP-15	BMSP-05	BMSP-25	250
	13,0 - 18,0	15,0	33	33	37,8	118,9	BMSP-16	BMSP-06	BMSP-26	250





Cable Protection Glands Polyamide

Cable protection glands with lamellar clamping

- For cable bending protection.
- Easy assembly.
- High quality strain relief and sealing, reliable performance for standard industrial applications.
- Up-to-date international approvals.

Technical Details

Material	Body, Cap	PA 6 (Polyamide 6)	
	Seal	CR (Chloroprene)	
Ingress Protection Rating		IP 68 - 5 Bar, 30 min	
		IP 66	
Flammability		V2 according to UL94	
Operating Temperature		Permanent	Intermittent
		-20 °C to +100 °C	-30 °C to +150 °C
Thread Type		<ul style="list-style-type: none"> • Metric EN 60423 • PG DIN 40430 • NPT ANSI B1.20.1 • Gas ISO 228 • Other thread types also available upon request. 	
	Cable Type	Non armoured	
Accessories		<ul style="list-style-type: none"> • Lock nuts • Reducing seals • Flat cable seals • Multihole seals • Gaskets (Washers) 	
		<ul style="list-style-type: none"> • Different Seal types available. • Manufactured according to DIN EN 62444/50262. • Accessories must be ordered separately. • We recommend the use of lock nuts and gaskets to ensure IP rating for rough surfaces or through holes. • Some approvals do not cover all sizes. 	
Remarks		Other colours on request:	
		<ul style="list-style-type: none"> • RAL 5015 (blue) • RAL 9003 (white) • RAL 3020 (red) 	

Approvals	Certificate Number	Standards
	134171	DIN EN 62444
	115116_0_000	CSA C22.2
	E199260	UL514B CSA22.2 No 18.3-12 CSA22.2 No 94.2-15
TYPE 4X		UL50E
	SERCOVAM RES 107572	UL514B §8.26.7
	E-14046	EN62444

For more approvals: see our webpage.

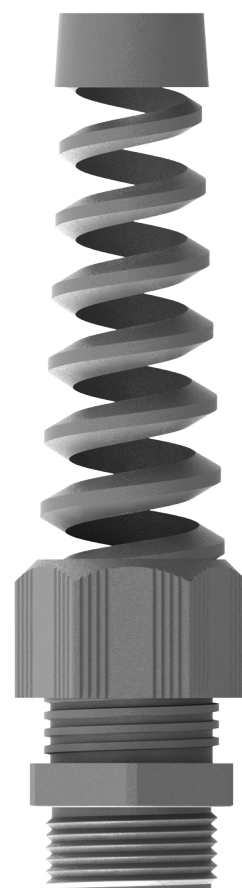
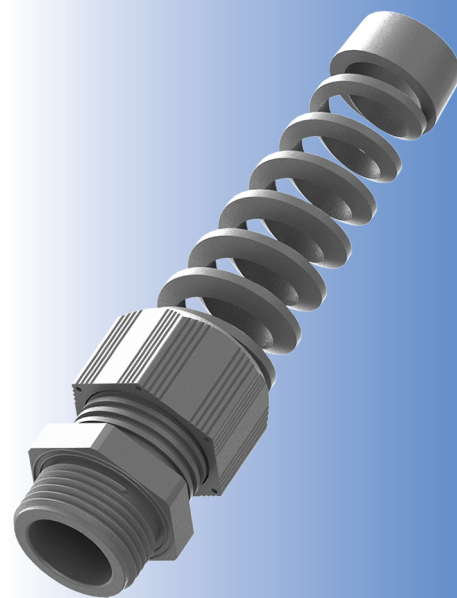

Cable Protection Glands Polyamide

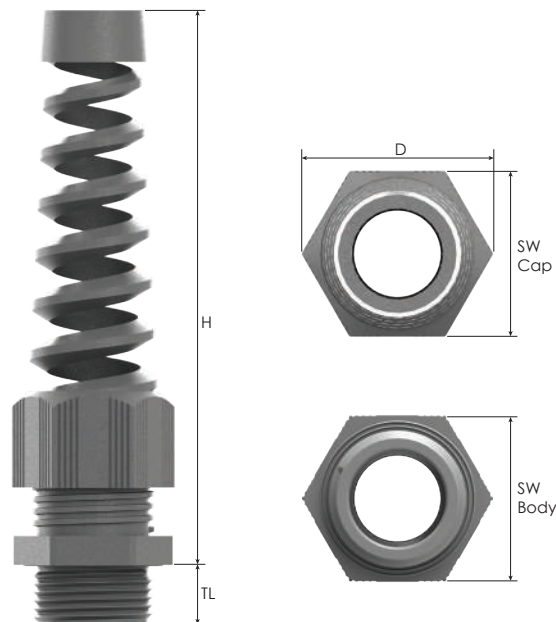

Thread Type **NPT** acc. to ANSI B1.20.1

Outer Thread Size (Male)	Clamping Range Ø min-max mm	Outer Thread Length TL mm	Spanner Width		Outer Ø D mm	max. Height H mm	Part Number			Minimum Order Quantity
			Cap	Body			RAL 7035 light grey	RAL 7001 grey	RAL 9005 black	
NPT 3/8"	3,0 - 7,0	15,0	22	22	25,1	83,2	BNSPA-11R	BNSPA-01R	BNSPA-21R	1000
	5,0 - 10,0	15,0	22	22	25,1	83,2	BNSPA-11	BNSPA-01	BNSPA-21	1000
NPT 1/2"	5,0 - 9,0	15,0	24	24	27,6	96,5	BNSPB-12R	BNSPB-02R	BNSPB-22R	750
	6,0 - 12,0	15,0	24	24	27,6	96,5	BNSPB-12	BNSPB-02	BNSPB-22	750
	7,0 - 12,0	15,0	27	27	30,5	106,4	BNSPC-12R	BNSPC-02R	BNSPC-22R	500
	10,0 - 14,0	15,0	27	27	30,5	106,4	BNSPC-12	BNSPC-02	BNSPC-22	500
NPT 3/4"	9,0 - 16,0	15,0	33	33	37,8	118,9	BNSPD-13R	BNSPD-03R	BNSPD-23R	250
	13,0 - 18,0	15,0	33	33	37,8	118,9	BNSPD-13	BNSPD-03	BNSPD-23	250

Thread Type **PG** acc. to DIN 40430

Outer Thread Size (Male)	Clamping Range Ø min-max mm	Outer Thread Length TL mm	Spanner Width		Outer Ø D mm	max. Height H mm	Part Number			Minimum Order Quantity
			Cap	Body			RAL 7035 light grey	RAL 7001 grey	RAL 9005 black	
PG 7	2,0 - 5,0	8,0	15	15	16,6	58,0	BSRP-11	BSRP-01	BSRP-21	2000
	3,0 - 6,5	8,0	15	15	16,6	58,0	BSSP-11	BSSP-01	BSSP-21	2000
PG 9	2,0 - 6,0	8,0	19	19	21,5	68,4	BSRP-12	BSRP-02	BSRP-22	1500
	4,0 - 8,0	8,0	19	19	21,5	68,4	BSSP-12	BSSP-02	BSSP-22	1500
PG 11	3,0 - 7,0	8,0	22	22	25,1	83,2	BSRP-13	BSRP-03	BSRP-23	1000
	5,0 - 10,0	8,0	22	22	25,1	83,2	BSSP-13	BSSP-03	BSSP-23	1000
PG 13,5	5,0 - 9,0	10,0	24	24	27,6	96,5	BSRP-14	BSRP-04	BSRP-24	750
	6,0 - 12,0	10,0	24	24	27,6	96,5	BSSP-14	BSSP-04	BSSP-24	750
PG 16	7,0 - 12,0	10,0	27	27	30,5	106,4	BSRP-15	BSRP-05	BSRP-25	500
	10,0 - 14,0	10,0	27	27	30,5	106,4	BSSP-15	BSSP-05	BSSP-25	500
PG 21	9,0 - 16,0	11,0	33	33	37,8	118,9	BSRP-16	BSRP-06	BSRP-26	250
	13,0 - 18,0	11,0	33	33	37,8	118,9	BSSP-16	BSSP-06	BSSP-26	250

Thread Type **G** acc. to G ISO 228

Outer Thread Size (Male)	Clamping Range Ø min-max mm	Outer Thread Length TL mm	Spanner Width		Outer Ø D mm	max. Height H mm	Part Number			Minimum Order Quantity
			Cap	Body			RAL 7035 light grey	RAL 7001 grey	RAL 9005 black	
G 3/8"	3,0 - 7,0	11,0	22	22	25,1	83,2	BFSR-11	BFSR-01	BFSR-21	1000
	5,0 - 10,0	11,0	22	22	25,1	83,2	BFSP-11	BFSP-01	BFSP-21	1000
G 1/2"	5,0 - 9,0	10,0	24	24	27,6	96,5	BFSR-12	BFSR-02	BFSR-22	750
	6,0 - 12,0	10,0	24	24	27,6	96,5	BFSP-12	BFSP-02	BFSP-22	750
	7,0 - 12,0	11,0	27	27	30,5	106,4	BFSR-13	BFSR-03	BFSR-23	500
	10,0 - 14,0	11,0	27	27	30,5	106,4	BFSP-13	BFSP-03	BFSP-23	500
G 3/4"	9,0 - 16,0	12,0	33	33	37,8	118,9	BFSR-14	BFSR-04	BFSR-24	250
	13,0 - 18,0	12,0	33	33	37,8	118,9	BFSP-14	BFSP-04	BFSP-24	250

Elbow Glands Polyamide

Elbow glands with lamellar clamping

- For cables guided along housing side.
- Easy assembly: install cable gland - insert cable - tighten cap.
- High quality strain relief and sealing, reliable performance for standard industrial applications..

Technical Details

Body, Cap	PA 6 (Polyamide 6)	
Material Sealing	CR (Chloroprene)	
O-Ring	NBR	
Ingress Protection Rating	IP 68 - 5 Bar, 30 min IP 66	
Flammability	V2 according to UL94	
Operating Temperature	Permanent	Intermittent
	-20 °C to +100 °C	-30 °C to +150 °C
Thread Type	<ul style="list-style-type: none"> • PG DIN 40430 • Other thread types also available upon request. 	
Cable Type	Non armoured	
Accessories	<ul style="list-style-type: none"> • Lock nuts • Dome plugs • Reducing seals • Flat cable seals • Multihole seals • Gaskets (Washers) 	
	<ul style="list-style-type: none"> • Different sealing types available. • Manufactured according to DIN EN 62444/50262. • We recommend the use of lock nuts and gaskets to ensure IP rating for rough surfaces or through holes. • Accessories must be ordered separately. 	
Remarks		

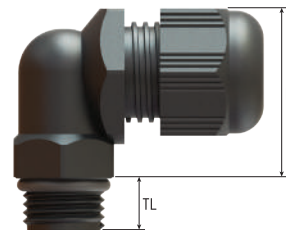

Thread Type PG acc. to DIN 40430

Outer Thread Size (Male)	Clamping Range Ø min-max mm	Outer Thread Length TL mm	Spanner Width		max. Height H mm	Part Number			Minimum Order Quantity
			Cap	Body		RAL 7035 light grey	RAL 7001 grey	RAL 9005 black	
			SW Cap mm	SW Body mm					
PG 7	3,0 - 6,0	8,0	19	19	26,5	EGR-11	EGR-01	EGR-21	2000
	4,0 - 8,0	8,0	19	19	26,5	EG-11	EG-01	EG-21	2000
PG 9	3,0 - 6,0	7,0	19	19	28,5	EGR-12	EGR-02	EGR-22	2000
	4,0 - 8,0	7,0	19	19	28,5	EG-12	EG-02	EG-22	2000

RJ 45 Glands Polyamide

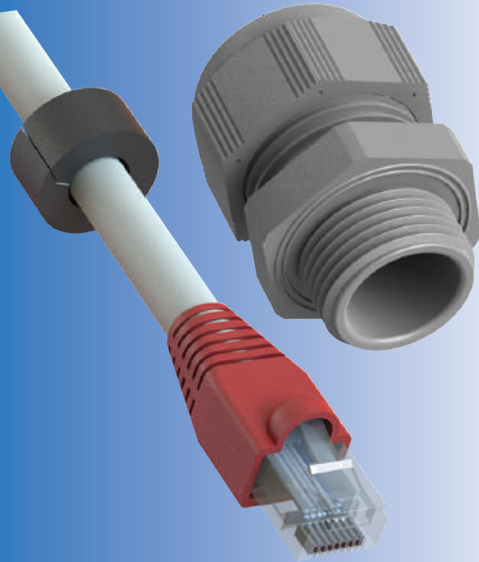

Cable glands for RJ 45 cables

- For standard industrial applications using data cables with pre-assembled RJ 45 connectors.
- Easy assembly: feed connector through cable gland - assemble splitted seal around cable - insert seal into gland body - install cable gland - tighten cap.
- High quality strain relief and sealing, reliable performance for standard industrial applications.

Technical Details		
Material	Body, Cap	PA 6 (Polyamide 6)
	Seal	CR (Chloroprene)
Ingress Protection Rating	IP 68 - 5 Bar, 30 min	
Flammability	V2 according to UL94	
Operating Temperature	Permanent	-20 °C to +80 °C
	Intermittent	-30 °C to +150 °C
Thread Type	<ul style="list-style-type: none"> • Metric EN 60423 • PG DIN 40430 • Other thread types also available upon request. 	
Cable Type	Non armoured, with pre-assembled RJ 45 connector.	
Accessories	• Lock nuts	
	• Dome plugs	
	• Gaskets (Washers)	
Remarks	• Manufactured according to DIN EN 62444/50262.	
	• We recommend the use of lock nuts and gaskets to ensure IP rating for rough surfaces or through holes.	
	• Accessories must be ordered separately.	

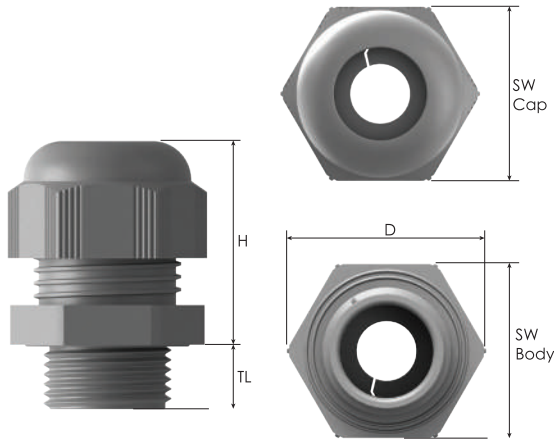

Thread Type METRIC acc. to EN 60423

Outer Thread Size (Male)	Cable Diameter Ø mm	Outer Thread Length TL mm	Spanner Width		Outer Ø D mm	max. Height H mm	Part Number			Minimum Order Quantity
			Cap	Body			RAL 7035 light grey	RAL 7001 grey	RAL 9005 black	
			SW Cap mm	SW Body mm						
M20x1,5	6,0	10,0	27	27	30,9	31,9	BMRJ-13	BMRJ-03	BMRJ-23	1000
	6,0	15,0	27	27	30,9	31,9	BMRJ-15	BMRJ-05	BMRJ-25	1000
M25x1,5	6,0	8,0	29	29	32,5	37,7	BMRJ-EN-13	BMRJ-EN-03	BMRJ-EN-23	800
	6,0	15,0	29	29	32,5	37,7	BMRJ-EN-13L	BMRJ-EN-03L	BMRJ-EN-23L	800
	6,0	10,0	33	33	37,2	38,4	BMRJ-16	BMRJ-06	BMRJ-26	400
	6,0	15,0	33	33	37,2	38,4	BMRJ-17	BMRJ-07	BMRJ-27	400

Thread Type PG acc. to DIN 40430

Outer Thread Size (Male)	Cable Diameter Ø mm	Outer Thread Length TL mm	Spanner Width		Outer Ø D mm	max. Height H mm	Part Number			Minimum Order Quantity
			Cap	Body			RAL 7035 light grey	RAL 7001 grey	RAL 9005 black	
			SW Cap mm	SW Body mm						
PG 16	6,0	10,0	27	27	30,9	31,9	BSRJ-15	BSRJ-05	BSRJ-25	1000
PG 21	6,0	11,0	33	33	37,2	38,4	BSRJ-16	BSRJ-06	BSRJ-26	600

Quick-Fit Cable Glands Polyamide

Cable glands without thread, special designs

- Specially designed cable glands.
- Easy assembly: install cable gland - insert cable - tighten cap.
- High quality strain relief and sealing, reliable performance for standard industrial applications.

Technical Details

Body, Cap	PA 6 (Polyamide 6)	
Material Seal	CR (Chloroprene)	
O-Ring	NBR	
Ingress Protection Rating	IP 68	
Flammability	V2 according to UL94	
Operating Temperature	Permanent	Intermittent
	-20 °C to +100 °C	-30 °C to +150 °C
Cable Type	Non armoured	
Accessories	• Dome plugs	
	• Reducing seals	
	• Flat cable seals	
	• Multihole seals	
Remarks	• Using O-rings, the available wall thickness is reduced (design Type B)	
	• Accessories must be ordered separately.	



Quick-Fit Cable Glands Polyamide

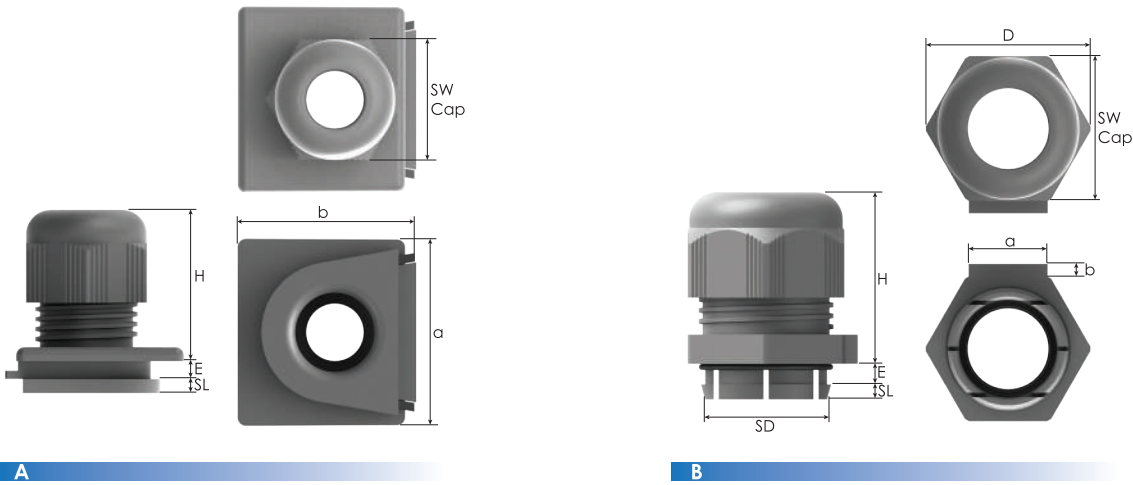

w/o thread

Size	Clamping Range	Snap Length		Wall		Spanner Width		Outer Ø	max. Height	Body Length		Design Type	Part Number			Minimum Order Quantity
		Ø min-max mm	SL mm	SD mm	Thickness E mm	Hole Ø HD mm	SW Cap mm			SW Body mm	a mm		b mm	RAL 7035 light grey	RAL 7001 grey	
16	7,0 - 12,0	2,5	-	3,2	-	27	-	30,9	30,8	34,1	32,5	A	QFVR-15	QFVR-05	QFVR-25	1000
	10,0 - 14,0	2,5	-	3,2	-	27	-	30,9	30,8	34,1	32,5	A	QFV-15	QFV-05	QFV-25	1000
21	9,0 - 16,0	7,5	26	4,3	26,3 - 26,5	33	33	37,2	38,5	18,0	2,8	B	QFR-16	QFR-06	QFR-26	1000
	13,0 - 18,0	7,5	26	4,3	26,3 - 26,5	33	33	37,2	38,5	18,0	2,8	B	QF-16	QF-06	QF-26	1000

Metal CABLE GLAND for Industrial Applications



Glands

Standard Cable Glands, Brass	20 - 23
Standard Cable Glands, Stainless Steel	24 - 27
Snap-In Cable Glands, Brass	28 - 29
Compression Type Cable Glands, Brass	30 - 31
Cable Protection Glands, Brass	32
Neoglands, Brass	33
Double Seal Glands, Brass	34
RJ-45 Cable Glands, Brass	35
Armoured Cable Glands	36 - 37

Metal CABLE GLANDS for Industrial Applications





Standard Cable Glands with Thread, Brass

Brass cable glands with lamellar clamping

- For standard industrial applications in harsh environments.
- Easy assembly.
- High quality strain relief and sealing reliable performance for standard industrial applications.
- Up-to-date international approvals

Technical Details		
Material	Body, Cap	Brass Nickel plated
	Seal	CR (Chloroprene)
	Clamping Insert	PA 6 (Polyamide 6)
	O-Ring	NBR
Ingress Protection Rating	IP 68 - 5 Bar, 30 min IP 66	
Flammability	V2 according to UL94	
Operating Temperature	Permanent	-20 °C to +100 °C
	Intermittent	-40 °C to +150 °C
Thread Type	<ul style="list-style-type: none"> • Metric EN 60423 • NPT ANSI B1.20.1 • PG DIN 40430 • Other thread types also available upon request. 	
Cable Type	Non armoured	
Accessories	<ul style="list-style-type: none"> • Lock nuts • Dome plugs • Reducing seals • Flat cable seals • Multihole seals • Gaskets (Washers) 	
	<ul style="list-style-type: none"> • Manufactured according to DIN EN 62444/50262. • We recommend the use of lock nuts and gaskets to ensure IP rating for rough surfaces or through holes. • Some approvals do not cover all sizes. • O-ring available in Metric and PG threads as a standard. For NPT threads O-ring available upon request. • Accessories must be ordered separately. 	
Remarks		

Approvals	Certificate Number	Standards
	40040034	acc. to DIN EN 62444
	E199260	UL514B CSA22.2 No 18.3-12 CSA22.2 No 94.2-15
		UL50E
TYPE 4x		
	E-14047	EN62444

For more approvals: see our webpage.



Order Coding			
Part Number	Gasket (Washer)	Lock Nut	Sealing Plug
Mandatory	- Option	Option	Option
See table	- WC Chloroprene - WS Silicone	L Lock Nut	P Dome Plug T Dust Plug
Example			
BMBE-E4	- WC	L	P

Standard Cable Glands with Thread, Brass

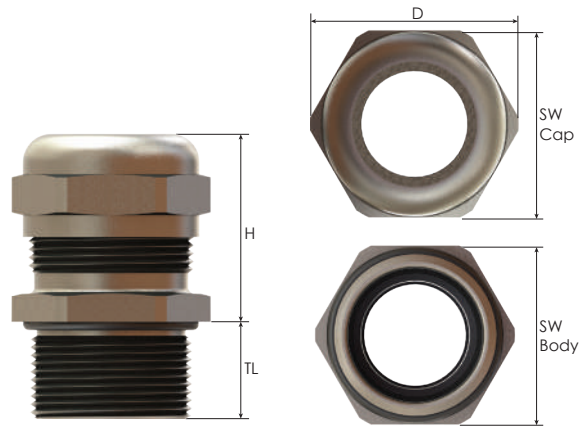



Thread Type **METRIC** acc. to EN 60423

Outer Thread Size (Male)	Clamping Range Ø min-max mm	Outer Thread Length TL mm	Spanner Width		Outer Ø D mm	max. Height		Part Number	Minimum Order Quantity
			Cap SW Cap mm	Body SW Body mm		H mm	H mm		
M12x1,5	2,0 - 5,0	6,0	14	14	15,5	24,0		BMBD-0S	1000
	2,0 - 5,0	12,0	14	14	15,5	24,0		BMBC-0SR	1000
	3,0 - 6,5	6,0	14	14	15,5	24,0		BMBC-0S	1000
	3,0 - 6,5	12,0	14	14	15,5	24,0		BMBC-0S	1000
M16x1,5	2,0 - 6,0	7,0	17	18	20,0	25,5		BMBD-01	900
	2,0 - 6,0	12,0	17	18	20,0	25,5		BMBC-01R	900
	3,0 - 7,0	7,0	20	20	22,0	30,5		BMBD-E1	600
	3,0 - 7,0	12,0	20	20	22,0	30,5		BMBC-E1R	600
	4,0 - 8,0	7,0	17	18	20,0	25,5		BMBD-01	900
	4,0 - 8,0	12,0	17	18	20,0	25,5		BMBC-01	900
	5,0 - 10,0	6,5	20	20	22,0	31,5		BMBD-01S	600
	5,0 - 10,0	7,0	20	20	22,0	30,5		BMBC-E1	600
	5,0 - 10,0	12,0	20	20	22,0	31,5		BMBC-01S	600
	5,0 - 10,0	12,0	20	20	22,0	31,5		BMBC-01S	600
M20x1,5	5,0 - 9,0	8,0	22	22	24,5	28,0		BMBD-E2	500
	5,0 - 9,0	12,0	22	22	24,5	28,0		BMBC-E2R	500
	6,0 - 12,0	8,0	22	22	24,5	26,5		BMBD-E2	500
	6,0 - 12,0	12,0	22	22	24,5	26,5		BMBC-E2	500
	7,0 - 13,0	8,0	24	24	26,5	30,5		BMBD-E2S	350
	10,0 - 14,0	8,0	24	24	26,5	30,0		BMBD-E2S	350
	10,0 - 14,0	12,0	24	24	26,5	30,0		BMBC-E2S	350
	10,0 - 14,0	12,0	24	24	26,5	30,0		BMBC-E2S	350
M25x1,5	7,0 - 12,0	8,0	24	27	30,0	30,0		BMBD-03	350
	7,0 - 12,0	12,0	24	27	30,0	30,0		BMBC-03R	350
	9,0 - 16,0	8,0	30	30	33,0	35,0		BMBD-03S	200
	9,0 - 16,0	12,0	30	30	33,0	35,0		BMBC-03SR	200
	10,0 - 14,0	8,0	24	27	30,0	30,0		BMBD-03	350
	10,0 - 14,0	12,0	24	27	30,0	30,0		BMBC-03	350
	11,0 - 17,0	8,0	27	27	30,0	32,5		BMBD-E3	350
	11,0 - 17,0	12,0	27	27	30,0	32,5		BMBC-E3	350
	13,0 - 18,0	8,0	30	30	33,0	35,0		BMBD-03S	200
	13,0 - 18,0	12,0	30	30	33,0	35,0		BMBC-03S	200
M32x1,5	9,0 - 16,0	9,0	30	34	37,5	35,0		BMBD-04	200
	9,0 - 16,0	15,0	30	34	37,5	35,0		BMBC-04R	200
	12,0 - 20,0	9,0	40	40	44,5	46,0		BMBD-04S	100
	12,0 - 20,0	15,0	40	40	44,5	46,0		BMBC-04SR	100
	13,0 - 18,0	9,0	30	34	37,5	35,0		BMBD-04	200
	13,0 - 18,0	15,0	30	34	37,5	35,0		BMBC-04	200
	15,0 - 21,0	8,0	34	34	37,5	38,0		BMBD-E4	200
	15,0 - 21,0	15,0	34	34	37,5	38,0		BMBC-E4	200
	18,0 - 25,0	9,0	40	40	44,5	46,0		BMBD-04S	100
	18,0 - 25,0	15,0	40	40	44,5	46,0		BMBC-04S	100
M40x1,5	12,0 - 20,0	9,0	40	43	48,5	40,5		BMBD-05	100
	12,0 - 20,0	15,0	40	43	48,5	40,5		BMBC-05R	100
	18,0 - 25,0	9,0	40	43	48,5	40,5		BMBD-05	100
	18,0 - 25,0	15,0	40	43	48,5	40,5		BMBC-05	100
	16,0 - 23,0	9,0	43	43	48,5	45,5		BMBD-E5	100
	16,0 - 23,0	15,0	43	43	48,5	45,5		BMBC-E5R	100
	19,0 - 28,0	9,0	43	43	48,5	45,5		BMBD-E5	100
	19,0 - 28,0	15,0	43	43	48,5	45,5		BMBC-E5	100
	22,0 - 32,0	9,0	50	50	55,5	54,5		BMBD-05S	50
	22,0 - 32,0	15,0	50	50	55,5	54,5		BMBC-05S	50
M50x1,5	20,0 - 26,0	9,0	50	55	61,0	50,0		BMBD-06	50
	20,0 - 26,0	15,0	50	55	61,0	50,0		BMBC-06R	50
	22,0 - 32,0	9,0	50	55	61,0	50,0		BMBD-06	50
	22,0 - 32,0	15,0	50	55	61,0	50,0		BMBC-06	50
	27,0 - 38,0	9,0	58	58	64,0	54,0		BMBD-E6	40
	27,0 - 38,0	15,0	58	58	64,0	54,0		BMBC-E6	40
	34,0 - 44,0	9,0	64	64	70,0	55,0		BMBD-06S	40
	34,0 - 44,0	15,0	64	64	70,0	55,0		BMBC-06S	40
M63x1,5	29,0 - 35,0	10,0	64	68	75,0	56,0		BMBD-E7	40
	29,0 - 35,0	14,0	64	68	75,0	55,0		BMBD-07	40
	29,0 - 35,0	18,0	64	68	75,0	55,0		BMBC-07R	40
	34,0 - 44,0	10,0	64	68	75,0	55,0		BMBD-E7	40
	34,0 - 44,0	15,0	64	68	75,0	56,0		BMBC-E7	40
	34,0 - 44,0	14,0	64	68	75,0	55,0		BMBD-07	40
	34,0 - 44,0	18,0	64	68	75,0	55,0		BMBC-07	40
	37,0 - 53,0	10,0	75	75	83,0	53,0		BMBD-07S	20
	37,0 - 53,0	18,0	75	75	83,0	53,0		BMBC-07S	20

Standard Cable Glands with Thread, Brass

Brass cable glands with lamellar clamping

- For standard industrial applications in harsh environments.
- Easy assembly.
- High quality strain relief and sealing reliable performance for standard industrial applications.
- Up-to-date international approvals

Technical Details		
Material	Body, Cap	Brass Nickel plated
	Seal	CR (Chloroprene)
	Clamping Insert	PA 6 (Polyamide 6)
	O-Ring	NBR
Ingress Protection Rating	IP 68 - 5 Bar, 30 min IP 66	
Flammability	V2 according to UL94	
Operating Temperature	Permanent	-20 °C to +100 °C
	Intermittent	-40 °C to +150 °C
Thread Type	<ul style="list-style-type: none"> • Metric EN 60423 • NPT ANSI B1.20.1 • PG DIN 40430 • Other thread types also available upon request. 	
Cable Type	Non armoured	
Accessories	<ul style="list-style-type: none"> • Lock nuts • Dome plugs • Reducing seals • Flat cable seals • Multihole seals • Gaskets (Washers) 	
	<ul style="list-style-type: none"> • Manufactured according to DIN EN 62444/50262. • We recommend the use of lock nuts and gaskets to ensure IP rating for rough surfaces or through holes. • Some approvals do not cover all sizes. • O-ring available in Metric and PG threads as a standard. For NPT threads O-ring available upon request. • Accessories must be ordered separately. 	
Remarks		
Approvals	Certificate Number	Standards
	40040034	acc. to DIN EN 62444
	E199260	UL514B CSA22.2 No 18.3-12 CSA22.2 No 94.2-1S
		UL50E
TYPE 4x		
	E-14047	EN62444

For more approvals: see our webpage.



Order Coding			
Part Number	Gasket (Washer)	Lock Nut	Sealing Plug
Mandatory	- Option	Option	Option
See table	- WC Chloroprene - WS Silicone	L Lock Nut	P Dome Plug T Dust Plug
Example			
BMBE-E4	- WC	L	P

Standard Cable Glands with Thread, Brass

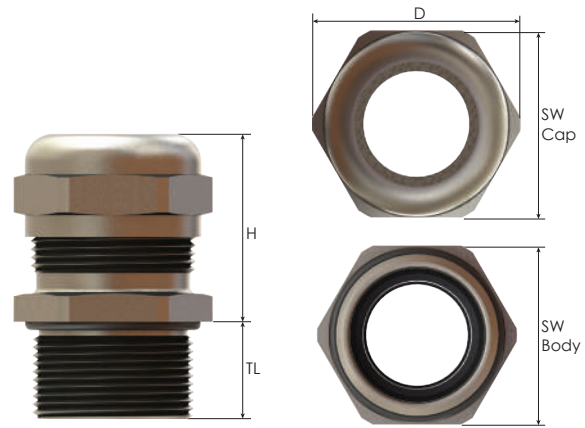

Thread Type **NPT** acc. to ANSI B1.20.1

Outer Thread Size (Male)	Clamping Range Ø min-max mm	Outer Thread Length TL mm	Spanner Width		Outer Ø D mm	max. Height H mm		Part Number	Minimum Order Quantity
			Cap SW Cap mm	Body SW Body mm					
NPT 3/8"	2,0 - 6,0	11,5	17	19	21,0	25,5	BNBD-01	900	
	3,0 - 7,0	11,5	20	20	22,0	31,5	BNBD-01S	600	
	4,0 - 8,0	11,5	17	19	21,0	25,5	BNBC-01	900	
	5,0 - 10,0	11,5	20	20	22,0	31,5	BNBC-01S	600	
NPT 1/2"	5,0 - 9,0	13,0	22	22	24,5	27,5	BNBD-02	500	
	6,0 - 12,0	13,0	22	22	24,5	27,5	BNBC-02	500	
	7,0 - 12,0	13,0	24	24	26,8	30,0	BNBD-02S	350	
	10,0 - 14,0	13,0	24	24	26,8	30,0	BNBC-02S	350	
NPT 3/4"	9,0 - 16,0	13,0	30	30	33,0	38,0	BNBD-03	350	
	13,0 - 18,0	13,0	30	30	33,0	38,0	BNBC-03	350	
NPT 1"	12,0 - 20,0	13,0	40	43	48,5	45,5	BNBD-04	200	
	18,0 - 25,0	13,0	40	43	48,5	45,5	BNBC-04	200	
NPT 1 1/4"	22,0 - 32,0	25,6	50	50	55,5	50,0	BNBC-05	50	
NPT 1 1/2"	30,0 - 38,0	26,0	58	58	64,0	51,0	BNBC-06	40	
NPT 2"	34,0 - 44,0	27,0	64	64	70,0	55,0	BNBC-07	40	

Thread Type **PG** acc. to DIN 40430



Outer Thread Size (Male)	Clamping Range Ø min-max mm	Outer Thread Length TL mm	Spanner Width		Outer Ø D mm	max. Height H mm		Part Number	Minimum Order Quantity
			Cap SW Cap mm	Body SW Body mm					
PG 7	2,0 - 5,0	6,0	14	14	15,5	24,0	BSBD-01	1000	
	2,0 - 5,0	10,0	14	14	15,5	24,0	BSBE-01R	1000	
	3,0 - 6,5	6,0	14	14	15,5	24,0	BSBC-01	1000	
	3,0 - 6,5	10,0	14	14	15,5	24,0	BSBE-01	1000	
PG 9	2,0 - 6,0	6,0	17	17	18,9	25,5	BSBD-02	900	
	2,0 - 6,0	10,0	17	17	18,9	25,5	BSBE-02R	900	
	4,0 - 8,0	6,0	17	17	18,9	25,5	BSBC-02	900	
	4,0 - 8,0	10,0	17	17	18,9	25,5	BSBE-02	900	
PG 11	3,0 - 7,0	6,0	20	20	22,0	28,0	BSBD-03	600	
	3,0 - 7,0	10,0	20	20	22,0	28,0	BSBE-03R	600	
	5,0 - 10,0	6,0	20	20	22,0	28,0	BSBC-03	600	
	5,0 - 10,0	10,0	20	20	22,0	28,0	BSBE-03	600	
PG 13,5	5,0 - 9,0	6,5	22	22	24,5	26,5	BSBD-04	500	
	5,0 - 9,0	10,0	22	22	24,5	26,5	BSBE-04R	500	
	6,0 - 12,0	6,5	22	22	24,5	26,5	BSBC-04	500	
	6,0 - 12,0	10,0	22	22	24,5	26,5	BSBE-04	500	
PG 16	7,0 - 12,0	6,5	24	24	26,5	30,0	BSBD-05	400	
	7,0 - 12,0	10,0	24	24	26,5	30,0	BSBE-05R	400	
	10,0 - 14,0	6,5	24	24	26,5	30,0	BSBC-05	400	
	10,0 - 14,0	10,0	24	24	26,5	30,0	BSBE-05	400	
PG 21	9,0 - 16,0	7,2	30	30	33,0	35,0	BSBD-06	200	
	9,0 - 16,0	12,0	30	30	33,0	35,0	BSBE-06R	200	
	13,0 - 18,0	7,2	30	30	33,0	35,0	BSBC-06	200	
	13,0 - 18,0	12,0	30	30	33,0	35,0	BSBE-06	200	
PG 29	12,0 - 20,0	8,0	40	40	44,5	40,5	BSBD-07	100	
	12,0 - 20,0	12,0	40	40	44,5	40,5	BSBE-07R	100	
	18,0 - 25,0	8,0	40	40	44,5	40,5	BSBC-07	100	
	18,0 - 25,0	12,0	40	40	44,5	40,5	BSBE-07	100	
PG 36	20,0 - 26,0	9,0	50	50	55,5	50,0	BSBD-08	50	
	20,0 - 26,0	14,0	50	50	55,5	50,0	BSBE-08R	50	
	22,0 - 32,0	9,0	50	50	55,5	50,0	BSBC-08	50	
	22,0 - 32,0	14,0	50	50	55,5	50,0	BSBE-08	50	
PG 42	25,0 - 31,0	12,0	58	58	64,0	51,0	BSBD-09	40	
	25,0 - 31,0	16,0	58	58	64,0	51,0	BSBE-09R	40	
	30,0 - 38,0	12,0	58	58	64,0	51,0	BSBC-09	40	
	30,0 - 38,0	16,0	58	58	64,0	51,0	BSBE-09	40	
PG 48	29,0 - 35,0	14,0	64	64	70,0	54,5	BSBD-10	40	
	29,0 - 35,0	18,0	64	64	70,0	54,5	BSBE-10R	40	
	34,0 - 44,0	14,0	64	64	70,0	54,5	BSBC-10	40	
	34,0 - 44,0	18,0	64	64	70,0	54,5	BSBE-10	40	

Standard Cable Glands with Thread, Stainless Steel

Stainless steel cable glands with lamellar clamping

- For high quality machines and housings.
- For high quality applications in corrosive environments.
- Applications: Outdoor, food industry, pharmaceutical industry and other sensitive applications.
- Easy assembly: install cable gland - insert cable - tighten cap.
- High quality strain relief and sealing, reliable performance for standard industrial applications.
- Up-to-date international approvals.

Technical Details

	Body, Cap	Stainless steel 1.4305 (AISI 303)	
Material	Seal	CR (Chloroprene)	
	Clamping Insert	PA 6 (Polyamide 6)	
	O-Ring	NBR	
Ingress Protection Rating	IP 68 - 5 Bar, 30 min		
Flammability	V2 according to UL94		
Operating Temperature	Permanent		Intermittent
	-20 °C to +100 °C		-40 °C to +150 °C
Thread Type	<ul style="list-style-type: none"> • Metric EN 60423 • PG DIN 40430 • NPT ANSI B1.20.1 • Other thread types also available upon request. 		
Cable Type	Non armoured		
Accessories	<ul style="list-style-type: none"> • Lock nuts • Dome plugs • Reducing seals • Flat cable seals • Multihole seals • Gaskets (Washers) 		
	<ul style="list-style-type: none"> • Different Seal types available. • Manufactured according to DIN EN 62444/50262. • We recommend the use of lock nuts and gaskets to ensure IP rating for rough surfaces or through holes. • Some approvals do not cover all sizes. • Accessories must be ordered separately. • Some approvals do not cover all sizes. • O-ring available in Metric and PG threads as a standard. For NPT threads O-ring available upon request. 		
Remarks	<p>Note: Applications of most cable glands don't require same parameters applied to tests. For applications strictly acc. to the approval definitions please consult data sheet.</p>		
Approvals	Certificate Number	Standards	
	40040034	DIN EN 62444	
	E199260	UL514B CSA22.2 No 18.3-12 CSA22.2 No 94.2-15	
		UL50E	
TYPE 4x			
	E-14047	EN62444	

For more approvals: see our webpage.

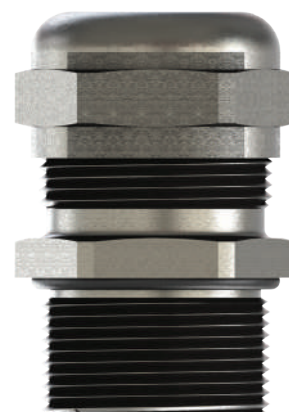

Order Coding				
Part Number	-	Gasket (Washer)	Lock Nut	Sealing Plug
Mandatory	-	Option	Option	Option
See table	-	WC Chloroprene WS Silicone	L Lock Nut	P Dome Plug T Dust Plug
Example				
BMSD-04	-	WC	L	P

Standard Cable Glands with Thread, Stainless Steel

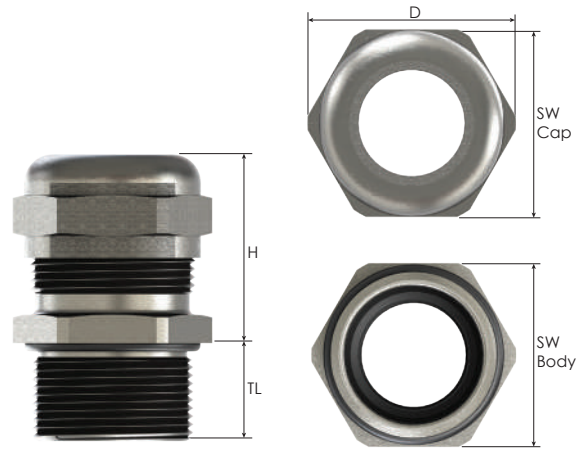



Thread Type **METRIC** acc. to EN 60423

Outer Thread Size (Male)	Clamping Range Ø min-max mm	Outer Thread Length TL mm	Spanner Width		Outer Ø D mm	max. Height		Part Number	Minimum Order Quantity
			Cap	Body		H mm			
M12x1,5	2,0 - 5,0	6,0	14	14	15,5	24,0		BMSD-0S	1000
	2,0 - 5,0	12,0	14	14	15,5	24,0		BMSE-0SR	1000
	3,0 - 6,5	6,0	14	14	15,5	24,0		BMSC-0S	1000
	3,0 - 6,5	12,0	14	14	15,5	24,0		BMSE-ES	1000
M16x1,5	2,0 - 6,0	7,0	17	19	21,0	25,5		BMSD-01	900
	2,0 - 6,0	12,0	17	19	21,0	25,5		BMSE-01R	900
	3,0 - 7,0	7,0	22	22	24,5	30,5		BMSD-E1	600
	3,0 - 7,0	12,0	22	22	24,5	30,5		BMSE-E1R	600
	4,0 - 8,0	7,0	17	19	21,0	25,5		BMSC-01	900
	4,0 - 8,0	12,0	17	19	21,0	25,5		BMSE-01	900
	5,0 - 10,0	7,0	22	22	24,5	30,5		BMSC-E1	600
	5,0 - 10,0	12,0	22	22	24,5	30,5		BMSE-E1	600
M20x1,5	5,0 - 9,0	8,0	22	22	24,5	26,5		BMSD-02	500
	5,0 - 9,0	12,0	22	22	24,5	28,0		BMSE-E2R	500
	6,0 - 12,0	8,0	22	22	24,5	26,5		BMSC-02	500
	6,0 - 12,0	12,0	22	22	24,5	28,0		BMSE-E2	500
	7,0 - 13,0	8,0	24	24	26,5	30,5		BMSC-E2S	350
	10,0 - 14,0	8,0	24	24	26,5	30,0		BMSC-02S	350
	10,0 - 14,0	12,0	24	24	26,5	30,0		BMSE-02S	350
M25x1,5	7,0 - 12,0	8,0	24	27	30,0	30,0		BMSD-03	350
	7,0 - 12,0	12,0	24	27	30,0	30,0		BMSE-03R	350
	9,0 - 16,0	8,0	30	30	33,0	35,0		BMSD-03S	200
	9,0 - 16,0	12,0	30	30	33,0	35,0		BMSE-03SR	200
	10,0 - 14,0	8,0	24	27	30,0	30,0		BMSC-03	350
	10,0 - 14,0	12,0	24	27	30,0	30,0		BMSE-03	350
	11,0 - 17,0	8,0	27	27	30,0	32,5		BMSC-E3	350
	11,0 - 17,0	12,0	27	27	30,0	32,5		BMSE-E3	350
	13,0 - 18,0	8,0	30	30	33,0	35,0		BMSC-03S	200
	13,0 - 18,0	12,0	30	30	33,0	35,0		BMSE-03S	200
	M32x1,5	9,0 - 16,0	9,0	30	36	39,8	35,0		BMSD-04
9,0 - 16,0		15,0	30	36	39,8	35,0		BMSE-04R	200
12,0 - 20,0		9,0	41	41	45,5	39,5		BMSD-04S	100
12,0 - 20,0		15,0	41	41	45,5	39,5		BMSE-04SR	100
13,0 - 18,0		9,0	30	36	39,8	35,0		BMSC-04	200
13,0 - 18,0		15,0	30	36	39,8	35,0		BMSE-04	200
15,0 - 21,0		8,0	36	36	39,8	38,0		BMSC-E4	200
15,0 - 21,0		15,0	36	36	39,8	38,0		BMSE-E4	200
18,0 - 25,0		9,0	41	41	45,5	39,5		BMSC-04S	100
18,0 - 25,0		15,0	41	41	45,5	39,5		BMSE-04S	100
M40x1,5	12,0 - 20,0	9,0	41	46	51,4	40,5		BMSD-05	100
	12,0 - 20,0	15,0	41	46	51,4	40,5		BMSE-05R	100
	16,0 - 23,0	9,0	46	46	51,4	45,5		BMSC-E5	100
	16,0 - 23,0	15,0	46	46	51,4	45,5		BMSE-E5R	100
	19,0 - 28,0	9,0	46	46	51,4	45,5		BMSC-E5	100
	19,0 - 28,0	15,0	46	46	51,4	45,5		BMSE-E5	100
	18,0 - 25,0	9,0	41	46	51,4	40,5		BMSC-05	100
	18,0 - 25,0	15,0	41	46	51,4	40,5		BMSE-05	100
	22,0 - 32,0	9,0	50	50	55,5	51,0		BMSC-05S	50
22,0 - 32,0	15,0	50	50	55,5	51,0		BMSE-05S	50	
M50x1,5	20,0 - 26,0	9,0	50	55	61,0	50,0		BMSD-06	50
	20,0 - 26,0	15,0	50	55	61,0	50,0		BMSE-06R	50
	22,0 - 32,0	9,0	50	55	61,0	50,0		BMSC-06	50
	22,0 - 32,0	15,0	50	55	61,0	50,0		BMSE-06	50
	27,0 - 38,0	9,0	60	60	66,5	54,0		BMSC-E6	40
	27,0 - 38,0	15,0	60	60	66,5	54,0		BMSE-E6	40
	34,0 - 44,0	9,0	65	65	71,0	55,0		BMSC-06S	40
34,0 - 44,0	15,0	65	65	71,0	55,0		BMSE-06S	40	
M63x1,5	29,0 - 35,0	10,0	65	70	77,0	56,0		BMSD-E7	40
	29,0 - 35,0	14,0	65	70	77,0	55,0		BMSD-07	40
	29,0 - 35,0	18,0	65	70	77,0	55,0		BMSE-07R	40
	34,0 - 44,0	10,0	65	70	77,0	56,0		BMSC-E7	40
	34,0 - 44,0	14,0	65	70	77,0	55,0		BMSC-07	40
	34,0 - 44,0	18,0	65	70	77,0	55,0		BMSE-07	40
	37,0 - 53,0	10,0	75	75	83,0	53,0		BMSC-07S	20
37,0 - 53,0	18,0	75	75	83,0	53,0		BMSE-07S	20	

Standard Cable Glands with Thread, Stainless Steel

Stainless steel cable glands with lamellar clamping

- For high quality machines and housings.
- For high quality applications in corrosive environments.
- Applications: Outdoor, food industry, pharmaceutical industry and other sensitive applications.
- Easy assembly: install cable gland - insert cable - tighten cap.
- High quality strain relief and sealing, reliable performance for standard industrial applications.
- Up-to-date international approvals.

Technical Details		
Material	Body, Cap	Stainless steel 1.4305 (AISI 303)
	Seal	CR (Chloroprene)
	Clamping Insert	PA 6 (Polyamide 6)
	O-Ring	NBR
Ingress Protection Rating	IP 68 - 5 Bar, 30 min	
Flammability	V2 according to UL94	
Operating Temperature	Permanent	-20 °C to +100 °C
	Intermittent	-40 °C to +150 °C
Thread Type	<ul style="list-style-type: none"> • Metric EN 60423 • PG DIN 40430 • NPT ANSI B1.20.1 • Other thread types also available upon request. 	
Cable Type	Non armoured	
Accessories	<ul style="list-style-type: none"> • Lock nuts • Dome plugs • Reducing seals • Flat cable seals • Multihole seals • Gaskets (Washers) 	
	<ul style="list-style-type: none"> • Different seal types available. • Manufactured according to DIN EN 62444/50262. • We recommend the use of lock nuts and gaskets to ensure IP rating for rough surfaces or through holes. • Some approvals do not cover all sizes. • Accessories must be ordered separately. • Some approvals do not cover all sizes. • O-ring available in Metric and PG threads as a standard. For NPT threads O-ring available upon request. 	
Remarks	<p>Note: Applications of most cable glands don't require same parameters applied to tests. For applications strictly acc. to the approval definitions please consult data sheet.</p>	
Approvals	Certificate Number	Standards
	40040034	DIN EN 62444
 TYPE 4x	E199260	UL514B CSA22.2 No 18.3-12 CSA22.2 No 94.2-1S
		UL50E
	E-14047	EN62444

For more approvals: see our webpage.



Order Coding			
Part Number	Gasket (Washer)	Lock Nut	Sealing Plug
Mandatory	- Option	Option	Option
See table	- WC Chloroprene WS Silicone	L Lock Nut	P Dome Plug T Dust Plug
Example			
BMSD-04	- WC	L	P

Standard Cable Glands with Thread, Stainless Steel

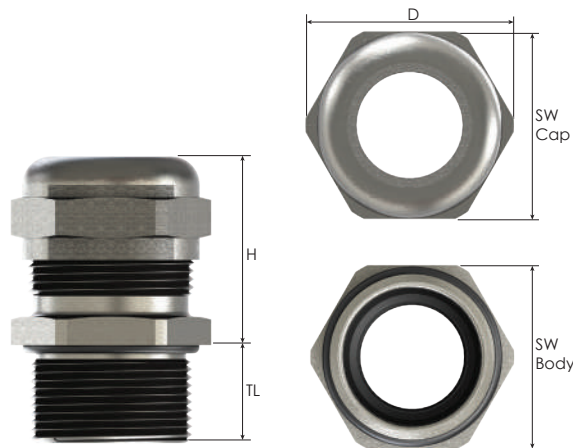

Thread Type **NPT** acc. to ANSI B1.20.1

Outer Thread Size (Male)	Clamping Range Ø min-max mm	Outer Thread Length TL mm	Spanner Width		Outer Ø D mm	max. Height H mm	Part Number	Minimum Order Quantity
			Cap SW Cap mm	Body SW Body mm				
NPT 3/8"	2,0 - 6,0	11,5	17	19	21,0	25,5	BNSD-01	900
	3,0 - 7,0	11,5	22	20	24,0	31,5	BNSD-01S	600
	4,0 - 8,0	11,5	17	19	21,0	25,5	BNSC-01	900
	5,0 - 10,0	11,5	22	20	24,0	31,5	BNSC-01S	600
NPT 1/2"	5,0 - 9,0	13,0	22	27	30,0	31,0	BNSD-02	500
	6,0 - 12,0	13,0	22	27	30,0	31,0	BNSC-02	500
	7,0 - 12,0	13,0	24	24	26,5	30,0	BNSD-02S	350
NPT 3/4"	10,0 - 14,0	13,0	24	24	26,5	30,0	BNSC-02S	350
	9,0 - 16,0	13,0	30	30	33,0	38,0	BNSD-03	200
NPT 1"	13,0 - 18,0	13,0	30	30	33,0	38,0	BNSC-03	200
	12,0 - 20,0	13,0	41	41	45,5	45,5	BNSD-04	100
NPT 1 1/4"	18,0 - 25,0	13,0	41	41	45,5	45,5	BNSC-04	100
	22,0 - 32,0	25,6	50	50	55,5	51,0	BNSC-05	50
NPT 1 1/2"	30,0 - 38,0	26,0	60	60	66,5	50,0	BNSC-06	40
NPT 2"	34,0 - 44,0	27,0	65	65	72,0	55,0	BNSC-07	40

Thread Type **PG** acc. to DIN 40430

Outer Thread Size (Male)	Clamping Range Ø min-max mm	Outer Thread Length TL mm	Spanner Width		Outer Ø D mm	max. Height H mm	Part Number	Minimum Order Quantity
			Cap SW Cap mm	Body SW Body mm				
PG 7	2,0 - 5,0	6,0	14	14	15,5	24,0	BSSD-01	1000
	2,0 - 5,0	10,0	14	14	15,5	24,0	BSSE-01R	1000
	3,0 - 6,5	6,0	14	14	15,5	24,0	BSSC-01	1000
	3,0 - 6,5	10,0	14	14	15,5	24,0	BSSE-01	1000
PG 9	2,0 - 6,0	6,0	17	19	21,0	25,5	BSSD-02	900
	2,0 - 6,0	10,0	17	19	21,0	25,5	BSSE-02R	900
	4,0 - 8,0	6,0	17	19	21,0	25,5	BSSC-02	900
PG 11	4,0 - 8,0	10,0	17	19	21,0	25,5	BSSE-02	900
	3,0 - 7,0	6,0	22	22	24,0	27,5	BSSD-03	600
	3,0 - 7,0	10,0	22	22	24,0	27,5	BSSE-03R	600
	5,0 - 10,0	6,0	22	22	24,0	27,5	BSSC-03	600
PG 13,5	5,0 - 10,0	10,0	22	22	24,0	27,5	BSSE-03	600
	5,0 - 9,0	6,5	22	22	24,0	26,0	BSSD-04	500
	5,0 - 9,0	10,0	22	22	24,0	26,0	BSSE-04R	500
	6,0 - 12,0	6,5	22	22	24,0	26,0	BSSC-04	500
PG 16	6,0 - 12,0	10,0	22	22	24,0	26,0	BSSE-04	500
	7,0 - 12,0	6,5	24	24	26,5	30,0	BSSD-05	400
	7,0 - 12,0	10,0	24	24	26,5	30,0	BSSE-05R	400
	10,0 - 14,0	6,5	24	24	26,5	30,0	BSSC-05	400
PG 21	10,0 - 14,0	10,0	24	24	26,5	30,0	BSSE-05	400
	9,0 - 16,0	7,2	30	30	33,0	35,0	BSSD-06	200
	9,0 - 16,0	12,0	30	30	33,0	35,0	BSSE-06R	200
	13,0 - 18,0	7,2	30	30	33,0	35,0	BSSC-06	200
PG 29	13,0 - 18,0	12,0	30	30	33,0	35,0	BSSE-06	200
	12,0 - 20,0	8,0	41	41	45,5	40,5	BSSD-07	100
	12,0 - 20,0	12,0	41	41	45,5	40,5	BSSE-07R	100
	18,0 - 25,0	8,0	41	41	45,5	40,5	BSSC-07	100
PG 36	18,0 - 25,0	12,0	41	41	45,5	40,5	BSSE-07	100
	20,0 - 26,0	9,0	50	50	55,5	50,0	BSSD-08	50
	20,0 - 26,0	14,0	50	50	55,5	50,0	BSSE-08R	50
	22,0 - 32,0	9,0	50	50	55,5	50,0	BSSC-08	50
PG 42	22,0 - 32,0	14,0	50	50	55,5	50,0	BSSE-08	50
	25,0 - 31,0	12,0	60	60	66,5	51,0	BSSD-09	40
	25,0 - 31,0	16,0	60	60	66,5	51,0	BSSE-09R	40
	30,0 - 38,0	12,0	60	60	66,5	51,0	BSSC-09	40
PG 48	30,0 - 38,0	16,0	60	60	66,5	51,0	BSSE-09	40
	29,0 - 35,0	14,0	65	65	72,0	54,5	BSSD-10	40
	29,0 - 35,0	18,0	65	65	72,0	54,5	BSSE-10R	40
	34,0 - 44,0	14,0	65	65	72,0	54,5	BSSC-10	40
34,0 - 44,0	18,0	65	65	72,0	54,5	BSSE-10	40	

Snap-In Cable Glands without Thread, Brass

Brass cable glands, without thread

- Easy assembly: push cable gland and turn body clockwise.
- For wall thickness 0,5 mm to 4,0 mm.
- High quality strain relief and sealing, reliable performance for standard industrial applications.
- Easy disassembly (with separate tool).

Technical Details

Material	Body, Cap	Brass Nickel plated	
	Seal	CR (Chloroprene)	
	Gasket	CR (Chloroprene)	
	Clamping Insert	PA 6 (Polyamide 6)	
	Lower Body	PA 6 (Polyamide 6)	
Ingress Protection Rating		IP 68 - 5 Bar, 30 min	
		IP 66	
Flammability	V2 according to UL94		
Approvals	The sealing material is UV approved.		
Operating Temperature	Permanent	-20 °C to +100 °C	Intermittent
			-40 °C to +150 °C
Cable Type	Non armoured		
Accessories	<ul style="list-style-type: none"> • Dome plugs • Reducing seals • Flat cable seals • Multihole seals • Disassembly tools (one piece included per Minimum Order Quantity) 		
	<ul style="list-style-type: none"> • Different Seal types available. • Manufactured according to DIN EN 62444/50262. • Accessories must be ordered separately. 		

Approvals	Certificate Number	Standards
	SERCOVAM RES 107572	UL514B §8.26.7



Assembling

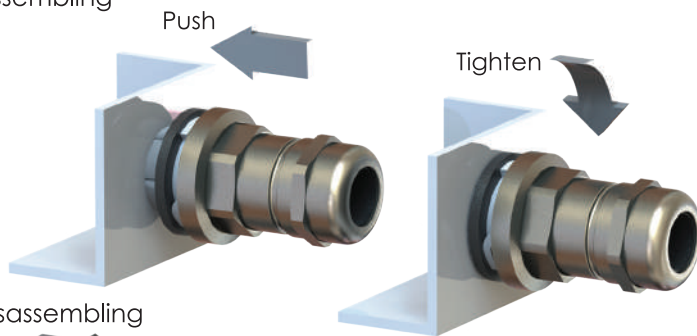

Disassembling

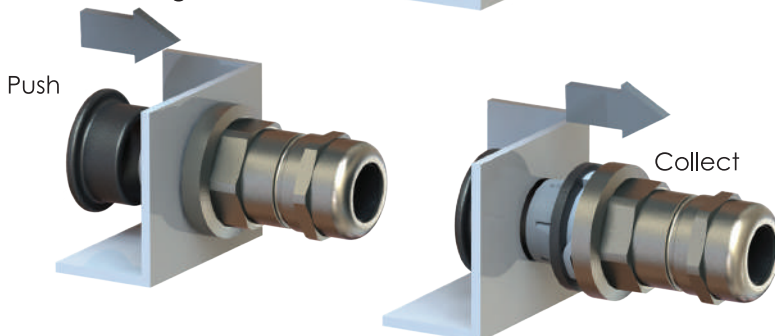

Snap-In Cable Glands without thread, Brass

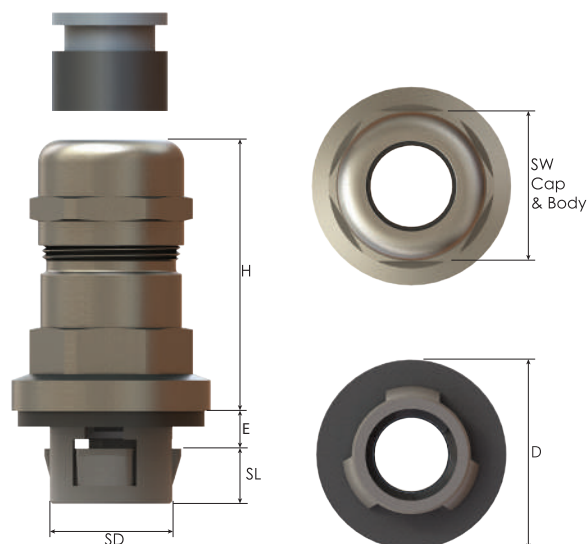

wall thickness (E) : 0,5 - 4,0 mm

Snap Size	Clamping Range		Snap Length		Enclosure Hole Ø	Spanner Width		Outer Ø	max. Height	Part Number	Minimum Order Quantity
	Ø min-max mm	Seal Type	SL mm	SD mm		SW Cap mm	SW Body mm				
16	3,0 - 7,0	Single	9,0	16,0	16,2 - 16,4	20	20	28,3	47,0	BBOS-11R	300
	5,0 - 10,0	Single	9,0	16,0	16,2 - 16,4	20	20	28,3	47,0	BBOS-11	300
	3,0 - 10,0	Double	9,0	16,0	16,2 - 16,4	20	20	28,3	47,0	BBOS-DS-11	300
20	5,0 - 9,0	Single	9,0	20,0	20,2 - 20,4	22	22	32,3	46,0	BBOS-12R	300
	6,0 - 12,0	Single	9,0	20,0	20,2 - 20,4	22	22	32,3	46,0	BBOS-12	300
	5,0 - 12,0	Double	9,0	20,0	20,2 - 20,4	22	22	32,3	46,0	BBOS-DS-12	300
25	9,0 - 13,0	Single	9,0	25,0	25,2 - 25,4	27	27	38,5	48,0	BBOS-EU-13R	200
	11,0 - 17,0	Single	9,0	25,0	25,2 - 25,4	27	27	38,5	48,0	BBOS-EU-13	200
	8,0 - 17,0	Double	9,0	25,0	25,2 - 25,4	27	27	38,5	48,0	BBOS-EU-DS-13	200
32	11,0 - 15,0	Single	9,0	32,0	32,2 - 32,4	34	34	45,5	56,5	BBOS-EU-14R	100
	15,0 - 21,0	Single	9,0	32,0	32,2 - 32,4	34	34	45,5	56,5	BBOS-EU-14	100
	11,0 - 21,0	Double	9,0	32,0	32,2 - 32,4	34	34	45,5	56,5	BBOS-EU-DS-14	100
40	16,0 - 23,0	Single	13,2	40,0	40,2 - 40,4	43	43	59,0	64,0	BBOS-EU-15R	50
	19,0 - 28,0	Single	13,2	40,0	40,2 - 40,4	43	43	59,0	64,0	BBOS-EU-15	50
	16,0 - 28,0	Double	13,2	40,0	40,2 - 40,4	43	43	59,0	64,0	BBOS-EU-DS-15	50

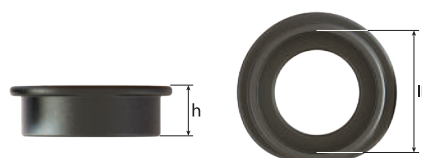
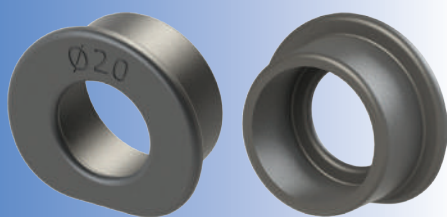

Snap-In Gland Disassembling Tool

Tool to disassemble Snap-In Glands

Technical Details

Material PA 6 (Polyamide 6)

For Gland Size	Inner Ø	Height	Part Number
	ID mm	h mm	
16	16,0	13,0	BEX-16
20	20,0	13,0	BEX-20
25	25,0	13,0	BEX-25
32	32,0	13,0	BEX-32
40	40,0	15,5	BEX-40

Compression Type Cable Glands with Thread, Brass

Cable glands for cables with large diameters

- For metal machines and housings.
- For standard industrial applications in harsh environments.
- For use of cables with large diameters.
- Easy assembly: install cable gland - insert cable - tighten cap.
- High quality strain relief and sealing, reliable performance for standard industrial applications.

Technical Details

Material	Body, Cap	Brass Nickel plated	
	Sealing	CR (Chloroprene)	
	O-Ring	NBR	
Ingress Protection Rating	IP 68 - 5 Bar, 30 min		
Flammability	V2 according to UL94		
Operating Temperature	Permanent	-20 °C to +100 °C	Intermittent
			-40 °C to +150 °C
Thread Type	<ul style="list-style-type: none"> • Metric EN 60423 • Other thread types also available upon request. 		
Cable Type	Non armoured		
Accessories	<ul style="list-style-type: none"> • Lock nuts • Gaskets 		
	<ul style="list-style-type: none"> • We recommend the use of lock nuts and gaskets to ensure IP rating for rough surfaces or through holes. • O-ring available in Metric threads. • Accessories must be ordered separately. 		
Remarks			

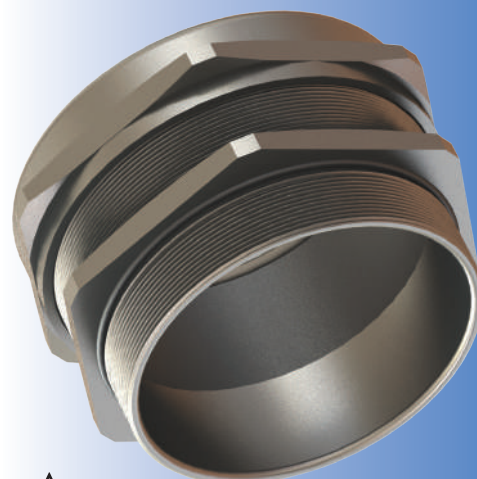

A

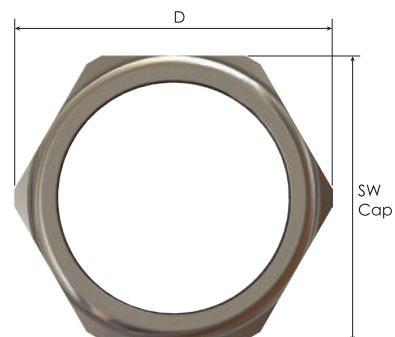

Thread Type METRIC acc. to EN 60423 (Type A)

Outer Thread Size (Male)	Clamping Range Ø min-max mm	Outer Thread Length TL mm	Spanner Width		Outer Ø D mm	max. Height H mm	Part Number	Minimum Order Quantity
			Cap SW Cap mm	Body SW Body mm				
M72x2,0	56,0 - 62,0	16,0	77	77	86,0	43,0	BDSM-08	20
M75x1,5	56,0 - 62,0	16,0	77	77	86,0	43,0	BDSM-09S	20
M75x2,0	56,0 - 64,0	16,0	90	90	100,0	50,5	BDSM-09	20
M80x2,0	50,0 - 56,0	18,0	90	90	100,0	51,5	BDSM-10R	10
	60,0 - 67,0	18,0	90	90	100,0	50,5	BDSM-10	10
M85x2,0	63,0 - 70,0	22,0	95	95	106,0	56,0	BDSM-11R	10
	68,0 - 77,0	22,0	95	95	106,0	54,0	BDSM-11	10
M90x2,0	68,0 - 77,0	22,0	95	100	111,0	54,0	BDSM-12	10

Compression Type Cable Glands with Thread, Brass

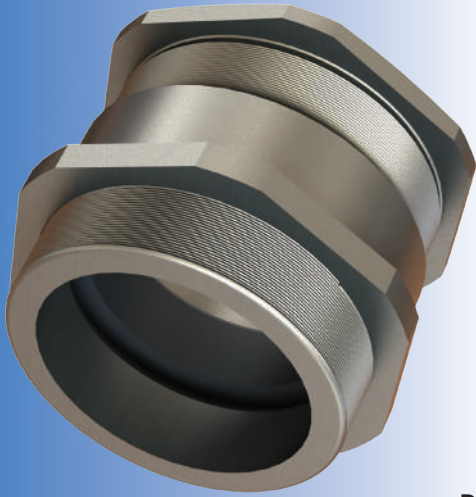

B

Cable glands for cables with large diameters

- For metal machines and housings.
- For standard industrial applications in harsh environments.
- For use of cables with large diameters.
- Easy assembly: install cable gland - insert cable - tighten cap.
- High quality strain relief and sealing, reliable performance for standard industrial applications.

Technical Details

Material	Body, Cap	Brass Nickel plated	
	Sealing	CR (Chloroprene)	
	O-Ring	NBR	
Ingress Protection Rating	IP 68 - 5 Bar, 30 min		
Flammability	V2 according to UL94		
Operating Temperature	Permanent	-20 °C to +100 °C	Intermittent
			-40 °C to +150 °C
Thread Type	<ul style="list-style-type: none"> • Metric EN 60423 • Other thread types also available upon request. 		
Cable Type	Non armoured		
Accessories	<ul style="list-style-type: none"> • Lock nuts • Gaskets 		
	<ul style="list-style-type: none"> • We recommend the use of lock nuts and gaskets to ensure IP rating for rough surfaces or through holes. • O-ring available in Metric threads. • Accessories must be ordered separately. 		
Remarks			

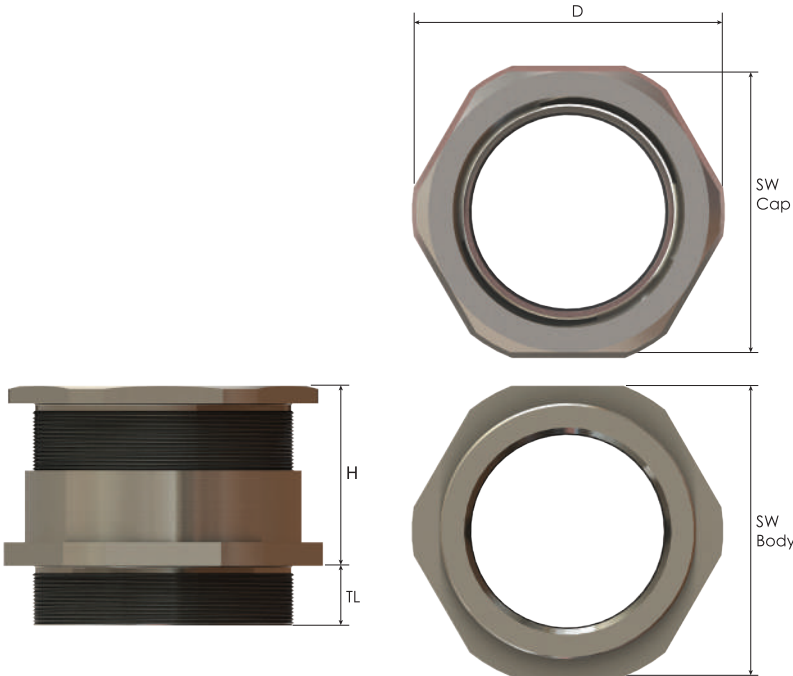

Thread Type METRIC acc. to EN 60423 (Type B)

Outer Thread Size (Male)	Clamping Range Ø min-max mm	Outer Thread Length TL mm	Spanner Width		Outer Ø D mm	max. Height H mm	Part Number	Minimum Order Quantity
			Cap SW Cap mm	Body SW Body mm				
M110x2,0	60,0 - 82,0	25,0	120	125	134,0	76,5	BDSM-13	6

Cable Protection Glands Brass

Cable protection glands with lamellar clamping, brass

- For cable bending protection.
- Easy assembly.
- High quality strain relief and sealing, reliable performance for standard industrial applications.

Technical Details

	Body, Cap	Brass, Nickel plated	
	Seal	CR (Chloroprene)	
Material	Clamping Insert	PA 6 (Polyamide 6)	
	Bending Spiral	Stainless steel (AISI 301)	
	O-ring	NBR	
	Ingress Protection Rating	IP 68 - 5 Bar, 30 min	
	Flammability	V2 according to UL94	
Operating Temperature	Permanent	-20 °C to +100 °C	
	Intermittent	-40 °C to +150 °C	
Thread Type	<ul style="list-style-type: none"> • Metric EN 60423 • PG DIN 40430 • Other thread types also available upon request. 		
Cable Type	Non armoured <ul style="list-style-type: none"> • Lock nuts • Reducing seals • Flat cable seals • Multihole seals • Gaskets (Washers) 		
Accessories	<ul style="list-style-type: none"> • Different sealing types available. • Manufactured according to DIN EN 62444/50262. 		
Remarks	<ul style="list-style-type: none"> • We recommend the use of lock nuts and gaskets to ensure IP rating for rough surfaces or through holes. • O-ring available in Metric and PG threads. • Accessories must be ordered separately. 		

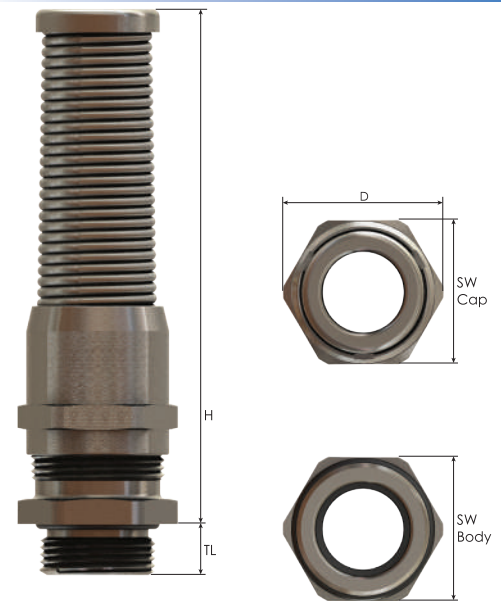

Thread Type METRIC acc. to EN 60423

Outer Thread Size (Male)	Clamping Range Ø min-max mm	Outer Thread Length TL mm	Spanner Width		Outer Ø D mm	max. Height		Part Number	Minimum Order Quantity
			Cap SW Cap mm	Body SW Body mm		H mm			
M12x1,5	3,0 - 6,5	6,0	14	14	15,5	60,0	BMBCSP-05	400	
	3,0 - 7,0	6,5	20	20	22,0	77,0	BMBDSP-01	300	
M16x1,5	5,0 - 10,0	6,5	20	20	22,0	77,0	BMBCSP-01	300	
	5,0 - 9,0	8,0	22	22	24,5	87,0	BMBDSP-02	200	
M20x1,5	6,0 - 12,0	8,0	22	22	24,5	87,0	BMBCSP-02	200	
	10,0 - 14,0	8,0	24	24	26,5	91,5	BMBCSP-02S	150	
M25x1,5	7,0 - 12,0	8,0	24	27	30,0	91,5	BMBDSP-03	150	
	10,0 - 14,0	8,0	24	27	30,0	91,5	BMBCSP-03	150	
M32x1,5	9,0 - 16,0	9,0	30	34	37,5	96,0	BMBDSP-04	150	
	13,0 - 18,0	9,0	30	34	37,5	96,0	BMBCSP-04	150	

Thread Type PG acc. to DIN 40430

Outer Thread Size (Male)	Clamping Range Ø min-max mm	Outer Thread Length TL mm	Spanner Width		Outer Ø D mm	max. Height		Part Number	Minimum Order Quantity
			Cap SW Cap mm	Body SW Body mm		H mm			
PG 11	3,0 - 7,0	6,0	20	20	22,0	73,5	BSBDSP-03	300	
	5,0 - 10,0	6,0	20	20	22,0	73,5	BSBCSP-03	300	
PG 13,5	5,0 - 9,0	6,5	22	22	24,5	86,0	BSBDSP-04	200	
	6,0 - 12,0	6,5	22	22	24,5	86,0	BSBCSP-04	200	
PG 16	7,0 - 12,0	6,5	24	24	26,5	91,5	BSBDSP-05	150	
	10,0 - 14,0	6,5	24	24	26,5	91,5	BSBCSP-05	150	
PG 21	9,0 - 16,0	7,2	30	30	33,0	96,5	BSBDSP-06	150	
	13,0 - 18,0	7,2	30	30	33,0	96,5	BSBCSP-06	150	



Cable glands for high quality sealing and strain relief

- For metal machines and housings.
- For demands of high quality sealing and strain relief.
- Single seal for full clamping range.
- For standard industrial applications in harsh environments.
- Easy assembly: install cable gland - insert cable - tighten cap.
- Reliable performance for standard industrial applications.

Technical Details

Material	Body, Cap	Brass, Brass Nickel plated, Brass Black Chrome Plated
	Seal	CR (Chloroprene)
	O-ring	NBR
Ingress Protection Rating	IP 68 - 5 Bar, 30 min	
Flammability	V2 according to UL94	
Operating Temperature	Permanent	
	-40 °C to +100 °C	
Thread Type	<ul style="list-style-type: none"> • Metric EN 60423 • Other thread types also available upon request. 	
Cable Type	Non armoured	
Accessories	<ul style="list-style-type: none"> • Lock nuts • Dome plugs • Gaskets (Washers) 	
	<ul style="list-style-type: none"> • Manufactured according to DIN EN 62444/50262. • We recommend the use of lock nuts and gaskets to ensure IP rating for rough surfaces or through holes. • O-ring available in Metric threads. • Accessories must be ordered separately. 	
Remarks		

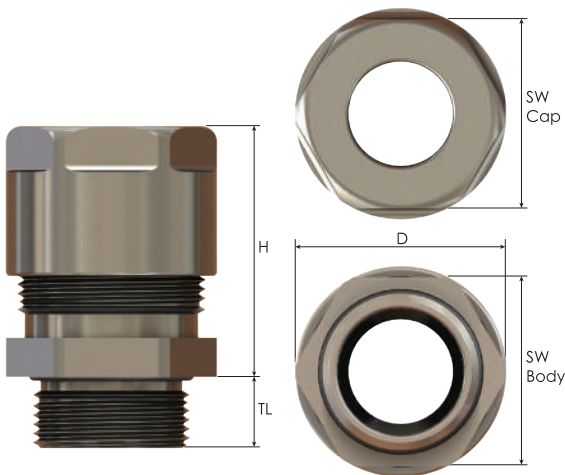

Thread Type **METRIC** acc. to EN 60423

Outer Thread Size (Male)	Clamping Range Ø min-max mm	Outer Thread Length TL mm	Spanner Width		Outer Ø D mm	max. Height H mm	Part Number		Minimum Order Quantity
			SW Cap mm	SW Body mm			Brass Nickel plated	Brass Black Chromate	
M16x1,5	4,0 - 11,0	8,0	21	21	23,3	31,5	BMNGB-01	BMNGC-01	300
M20x1,5	5,0 - 13,0	9,0	24	24	26,8	34,0	BMNGB-02	BMNGC-02	300
	6,5 - 15,5	10,0	28	28	30,8	38,0	BMNGB-03S	BMNGC-03S	200
M25x1,5	10,0 - 20,0	10,0	30	30	33,5	46,5	BMNGB-03L	BMNGC-03L	200

Double Seal Cable Glands Compact Design, Brass

Double seal glands, compact design

- For metal machines and housings.
- For standard industrial applications in harsh environments.
- Compact design.
- Double seal optimizes the cable range used.
- Easy assembly; install cable gland - insert cable - tighten cap.
- Special design for high quality strain relief and sealing, reliable performance for standard industrial applications.

Technical Details

Material	Body, Cap	Brass Nickel plated	
	Seal	NBR, Silicone	
	O-ring	NBR, Silicone	
Ingress Protection Rating	IP 68 - 5 Bar, 30 min		
Flammability	V2 according to UL94		
Operating Temperature	Seal	Permanent	Intermittent
	NBR	-20 °C to +100 °C	-40 °C to +150 °C
	Silicone	-60 °C to +140 °C	-60 °C to +180 °C
Thread Type	<ul style="list-style-type: none"> • Metric EN 60423 • PG DIN 40430 • Other thread types also available upon request. 		
Cable Type	Non armoured		
Accessories	<ul style="list-style-type: none"> • Lock nuts • Dome plugs • Gaskets (Washers) 		
Remarks	<ul style="list-style-type: none"> • We recommend the use of lock nuts and gaskets to ensure IP rating for rough surfaces or through holes. • O-ring available in Metric and PG threads. • Accessories must be ordered separately. 		



Order Coding	
Part Number	Seal
Mandatory	Option
See table	S Silicone
Example	
BDSM	S

Large Temperature Range

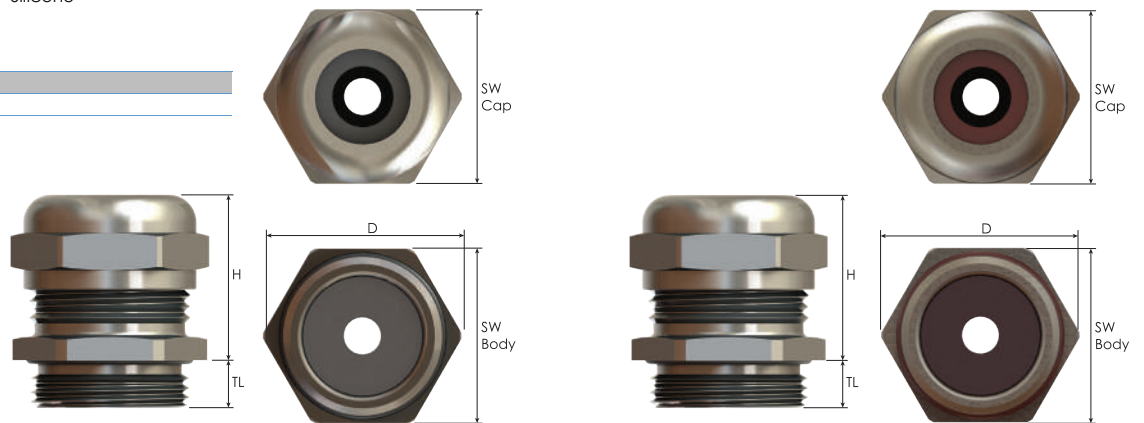

Thread Type METRIC acc. to EN 60423

Outer Thread Size (Male)	Clamping Range		Outer Thread Length TL mm	Spanner Width		Outer Ø D mm	max. Height H mm	Part Number	Minimum Order Quantity
	Outer Seal Ø min-max mm	Double Seal Ø min-max mm		Cap SW Cap mm	Body SW Body mm				
M12x1,5	4,0 - 6,0	-	6,0	14	14	15,8	20,0	BDSM-0S	1000
M16x1,5	6,5 - 9,0	4,0 - 6,0	5,1	18	18	20,0	20,5	BDSM-01	900
M20x1,5	7,0 - 12,0	4,5 - 7,0	6,0	22	22	24,5	23,0	BDSM-02	500
M25x1,5	14,0 - 17,5	10,0 - 13,0	7,0	28	28	31,0	24,5	BDSM-03	350
M32x1,5	19,0 - 23,5	14,5 - 18,0	8,0	35	35	38,8	27,5	BDSM-04	200
M40x1,5	23,5 - 27,0	16,5 - 23,5	8,0	43	43	47,0	38,0	BDSM-05	100

Thread Type PG acc. to DIN 40430

Outer Thread Size (Male)	Clamping Range		Outer Thread Length TL mm	Spanner Width		Outer Ø D mm	max. Height H mm	Part Number	Minimum Order Quantity
	Outer Seal Ø min-max mm	Double Seal Ø min-max mm		Cap SW Cap mm	Body SW Body mm				
PG 7	4,0 - 7,0	-	6,0	14	14	15,8	20,0	BDSP-01	1000
PG 9	6,0 - 10,0	4,0 - 6,0	6,0	18	18	20,0	20,5	BDSP-02	900
PG 11	7,0 - 12,0	4,5 - 7,0	6,0	22	22	24,5	22,5	BDSP-03	600
PG 13,5	10,0 - 15,0	8,0 - 10,0	6,0	24	24	26,5	23,0	BDSP-04	500
PG 16	10,0 - 15,0	8,0 - 10,0	6,0	24	25	27,5	23,0	BDSP-05	350
PG 21	13,0 - 20,0	10,0 - 13,0	7,6	32	32	35,5	27,0	BDSP-06	200
PG 29	21,5 - 28,0	19,0 - 21,5	8,0	40	40	45,2	27,5	BDSP-07	100
PG 36	30,0 - 35,0	26,0 - 30,0	8,0	50	50	56,9	30,5	BDSP-08	50
PG 42	39,0 - 44,5	35,0 - 39,0	10,0	58	58	64,0	34,5	BDSP-09	40
PG 48	40,0 - 48,0	37,0 - 40,0	11,0	64	64	70,0	36,0	BDSP-10	40

RJ 45 Cable Glands Brass



Cable glands for RJ 45 cables

- For standard industrial applications using data cables with pre-assembled cables with RJ 45 connectors.
- For metal machines and housings.
- For industrial applications in harsh environments.
- Easy assembly: feed connector through cable gland - assemble splitted seal around cable - insert seal into gland body - install cable gland - tighten cap.
- High quality strain relief and sealing, reliable performance for standard industrial applications.

Technical Details

Material	Body, Cap	Brass Nickel plated	
	Seal	CR (Chloroprene)	
	O-ring	NBR	
Ingress Protection Rating	IP 68 - 5 Bar, 30 min		
Flammability	V2 according to UL94		
Operating Temperature	Permanent	-20 °C to +100 °C	
	Intermittent	-40 °C to +150 °C	
Thread Type	<ul style="list-style-type: none"> • Metric EN 60423 • PG DIN 40430 • Other thread types also available upon request. 		
Cable Type	Non armoured, with pre-assembled RJ45 connector		
Accessories	<ul style="list-style-type: none"> • Lock nuts • Dome plugs • Gaskets 		
	<ul style="list-style-type: none"> • Manufactured according to DIN EN 62444/50262. • We recommend the use of lock nuts and gaskets to ensure IP rating for rough surfaces or through holes. • O-ring available in Metric and PG threads. • Accessories must be ordered separately. 		
	Remarks		

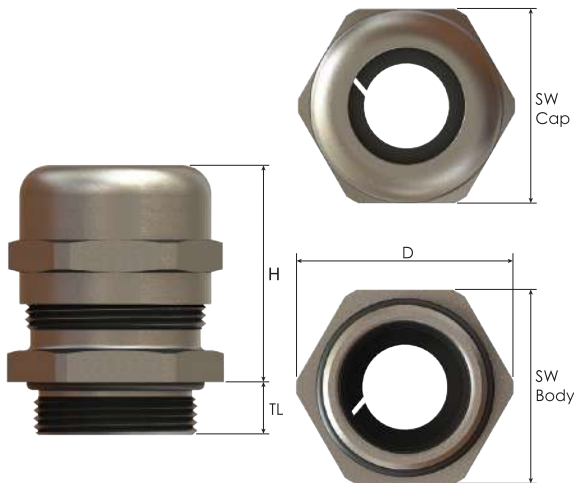

Thread Type **METRIC** acc. to EN 60423

Outer Thread Size (Male)	Cable Diameter Ø max mm	Outer Thread Length TL mm	Spanner Width		Outer Ø D mm	max. Height H mm	Part Number	Minimum Order Quantity
			Cap SW Cap mm	Body SW Body mm				
M20x1,5	6,0	8,0	24	24	26,5	30,0	BMBCRJ-02S-A	350
	6,0	12,0	24	24	26,5	30,0	BMBCRJ-02S-D	350
	9,0	8,0	24	24	26,5	30,0	BMBCRJ-02S-C	350
	9,0	6,0	24	24	26,5	30,0	BMBCRJ-02S-B	350
M25x1,5	6,0	8,0	24	27	30,0	30,0	BMBCRJ-03-A	350
	6,0	8,0	27	27	30,0	32,5	BMBCRJ-E3-A	350
	6,0	10,0	30	30	33,0	35,0	BMBCRJ-03S-A	350
	6,0	12,0	24	27	30,0	30,0	BMBCRJ-03-C	350
M32x1,5	9,0	8,0	24	27	30,0	30,0	BMBCRJ-03-B	350
	6,0	9,0	30	34	37,5	35,0	BMBCRJ-04-A	200
M40x1,5	8,0	9,0	43	43	48,4	45,5	BMBCRJ-E5-A	100
	8,0	15,0	43	43	48,4	45,5	BMBCRJ-E5-B	100

Thread Type **PG** acc. to DIN 40430

Outer Thread Size (Male)	Cable Diameter Ø max mm	Outer Thread Length TL mm	Spanner Width		Outer Ø D mm	max. Height H mm	Part Number	Minimum Order Quantity
			Cap SW Cap mm	Body SW Body mm				
PG 13,5	9,0	6,5	24	24	26,5	30,0	BSBCRJ-04S-A	500
PG 16	6,0	6,5	24	24	26,5	30,0	BSBCRJ-05-A	400
	6,0	10,0	24	24	26,5	30,0	BSBERJ-05-B	400
PG 21	6,0	7,2	30	30	33,0	35,0	BSBCRJ-06-A	200
	6,0	12,0	30	30	33,0	35,0	BSBERJ-06-B	200

Armoured Cable Glands

Cable glands for armoured cables

- Specially designed cable glands for armoured cables. Large temperature range applications.
- Easy assembly: install cable gland - prepare steel wires - insert cable - tighten cap.
- High quality strain relief and sealing, reliable performance for standard industrial applications.

Technical Details

Cable Gland	Brass, Brass Nickel plated, Stainless Steel	
Material	Brass, Brass Nickel plated, Stainless Steel	
Inner Part	Brass, Brass Nickel plated, Stainless Steel	
Sealing	CR (Chloroprene), Silicone	
Ingress Protection Rating	IP 66	
Operating Temperature	Seal Material	
	CR (Chloroprene)	Silicone
	-40 °C to +100 °C	-60 °C to +180 °C
Thread Type	<ul style="list-style-type: none"> • Metric EN 60423 • NPT ANSI B1.20.1 • Other thread types also available upon request. 	
Cable Type	SWA, SWB, AWA, STA and Shielded	
Accessories	<ul style="list-style-type: none"> • Lock nuts • Gaskets (Washers) • Shroud 	
Remarks	<ul style="list-style-type: none"> • Manufactured according to DIN EN 62444/50262. • We recommend the use of lock nuts and gaskets to ensure IP rating for rough surfaces or through holes. • Accessories must be ordered separately. 	

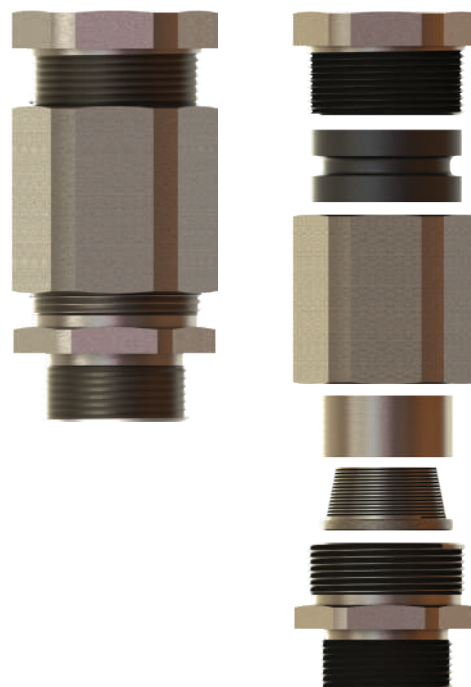

Order Coding					
Part Number	Seal	Material	- Gasket (Washer)	Lock Nut	Shroud
Mandatory	Mandatory	Mandatory	- Option	Option	Option
See table	C CR (Chloroprene) S Silicone	B Brass BN Brass Nickel plated X Stainless steel	- WC CR (Chloroprene) WS Silicone	L Lock nut	S Shroud
ShroExample					
KBET2LM	S	BN	- WC	L	S

Armoured Cable Glands

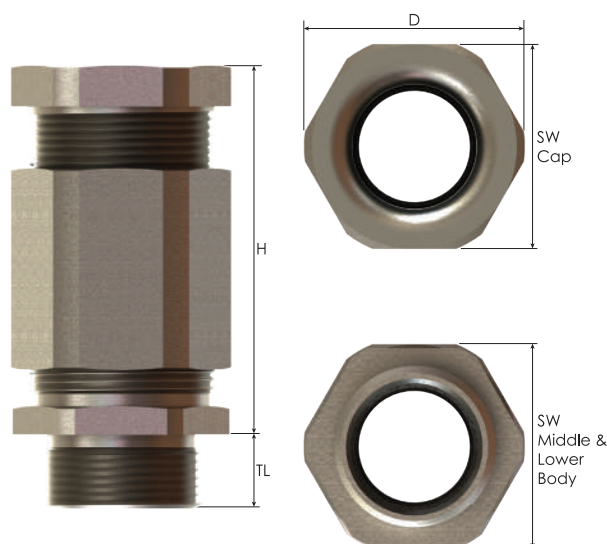

Thread Type **METRIC** acc. to EN 60423

Outer Thread Size (Male)	Clamping Range Ø min-max mm	Armour Wire Ø min-max mm	Outer Thread Length TL mm	Spanner Width			Outer Ø D mm	max. Height H mm	Part Number	Minimum Order Quantity
				Cap SW Cap mm	Middle Body SW Middle Body mm	Lower Body SW Lower Body mm				
M16x1,5	8,0 - 15,0	0,3 - 1,3	9,0	25	25	24	27,0	42,5	KBET01M	70
	8,0 - 15,0	0,3 - 1,3	9,0	25	25	24	27,0	42,5	KBET1M	70
M20x1,5	13,5 - 21,0	0,4 - 1,3	9,0	30	30	29	33,0	43,5	KBET1LM	70
	8,0 - 15,0	0,3 - 1,3	9,0	25	25	25	27,0	42,5	KBET2SM	70
M25x1,5	13,5 - 21,0	0,4 - 1,3	9,0	30	30	29	33,0	43,5	KBET2M	70
	18,0 - 27,0	0,4 - 1,6	9,0	40	40	40	44,5	50,0	KBET2LM	40
M32x1,5	18,0 - 27,0	0,4 - 1,6	9,0	40	40	40	44,5	50,0	KBET3SM	40
	23,0 - 33,0	0,4 - 2,0	9,0	43	43	43	47,0	53,5	KBET3M	40
M40x1,5	29,0 - 40,0	0,4 - 2,0	9,0	52	52	52	59,0	57,0	KBET4M	24
M50x1,5	35,0 - 48,0	0,4 - 2,5	9,0	60	60	60	66,5	69,5	KBET5SM	12
	42,0 - 56,0	0,6 - 2,5	9,0	75	74	70	83,0	76,5	KBET5M	12
M63x1,5	42,0 - 56,0	0,6 - 2,5	9,0	75	74	70	83,0	76,5	KBET6SM	12
	53,0 - 66,0	0,6 - 2,5	9,0	85	85	80	94,0	77,5	KBET6M	12
M75x1,5	53,0 - 66,0	0,6 - 2,5	9,0	85	85	80	94,0	77,5	KBET7SM	5
	63,0 - 75,0	0,6 - 2,5	9,0	95	95	90	105,0	81,0	KBET7M	5

Thread Type **NPT** acc. to ANSI B1.20.1

Outer Thread Size (Male)	Clamping Range Ø min-max mm	Armour Wire Ø min-max mm	Outer Thread Length TL mm	Spanner Width			Outer Ø D mm	max. Height H mm	Part Number	Minimum Order Quantity
				Cap SW Cap mm	Middle Body SW Middle Body mm	Lower Body SW Lower Body mm				
NPT 3/8"	8,0 - 15,0	0,3 - 1,3	16,0	25	25	24	27,0	42,5	KBET01N	70
NPT 1/2"	8,0 - 15,0	0,3 - 1,3	16,0	25	25	24	27,0	42,5	KBET1N	70
	13,5 - 21,0	0,4 - 1,3	16,0	30	30	29	33,0	43,5	KBET1LN	70
NPT 3/4"	8,0 - 15,0	0,3 - 1,3	16,0	25	25	27	30,0	42,5	KBET2SN	70
	13,5 - 21,0	0,4 - 1,3	16,0	30	30	29	33,0	43,5	KBET2N	70
NPT 1"	18,0 - 27,0	0,4 - 1,6	16,0	40	40	40	44,5	50,0	KBET2LN	40
	18,0 - 27,0	0,4 - 1,6	21,0	40	40	40	44,5	50,0	KBET3SN	40
NPT 1 1/4"	23,0 - 33,0	0,4 - 2,0	21,0	43	43	43	47,0	53,5	KBET3N	40
	29,0 - 40,0	0,4 - 2,0	21,0	52	52	52	59,0	57,0	KBET4N	24
NPT 1 1/2"	35,0 - 48,0	0,4 - 2,5	21,0	60	60	60	66,5	69,5	KBET5SN	12
	42,0 - 56,0	0,6 - 2,5	21,0	75	74	70	83,0	76,5	KBET5N	12
NPT 2"	42,0 - 56,0	0,6 - 2,5	21,0	75	74	70	83,0	76,5	KBET6SN	12
	53,0 - 66,0	0,6 - 2,5	21,0	85	85	80	94,0	77,5	KBET6N	12
NPT 2 1/2"	53,0 - 66,0	0,6 - 2,5	21,0	85	85	80	94,0	77,5	KBET7SN	5
	63,0 - 75,0	0,6 - 2,5	21,0	95	95	90	105,0	81,0	KBET7N	5

Metal EMC CABLE GLANDS for Industrial Applications



Glands

EMC 2 Cable Glands, Brass	42 - 45
EMC 3 Cable Glands, Brass	46 - 49
EMC 4 Cable Glands, Brass	50 - 53
Snap-In Cable Glands, EMC 4, Brass	54 - 55
Cable Protection Glands, EMC 2, Brass	56 - 57

Metal EMC CABLE GLANDS for Industrial Applications



EMC Cable Glands

In order to avoid electromagnetic interference EMC cable glands include a special EMC component that enlarges the contact with the cable shield .

High performance cable gland properties

- Ingress protection rating IP 68
- High quality strain relief
- Easy assembly

High performance EMC properties

- Excellent shielding
- Long lasting shield contact
- Low derating at high electrical current loads

Shielding Attenuation

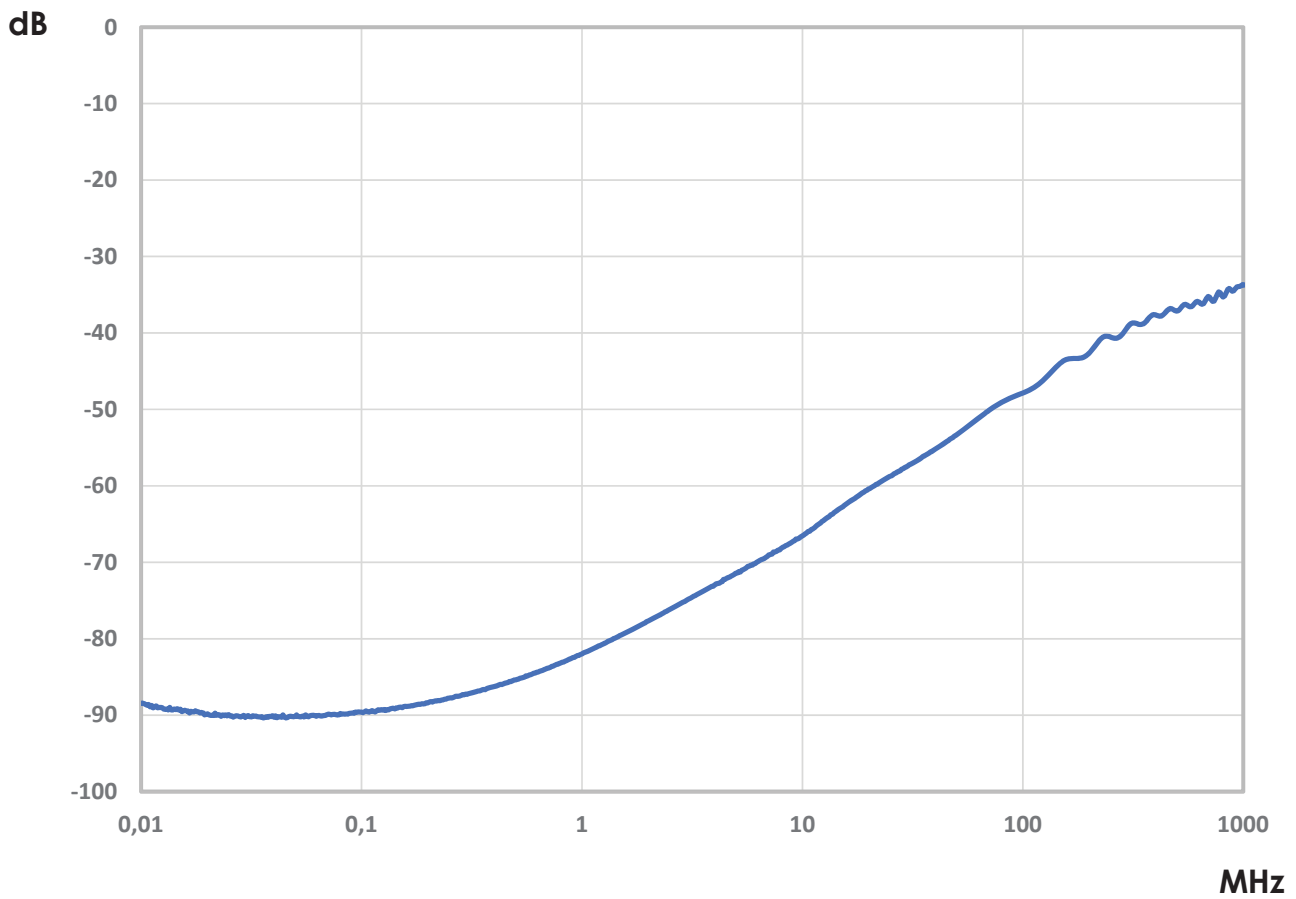

EMC 2 Cable Glands Brass

These EMC cable glands combine several advantages in one product. First, you get the same clamping ranges as the standard brass glands. The Ingress Protection Rating is IP68. In order to get a low electrical impedance between the cable gland and the braiding of the cable the cable gland does not have to be disassembled. Secondly, a perfect shielding will be achieved by just tightening the dome nut. This high tech cable gland consists of a nickel plated brass body, PA6 clamping insert, an EMC contact element and choloprene seal. The components are pre-assembled.

To install an EMC cable gland remove approx. 5 – 10 mm (0.20 – 0.39) of the insulation of the cable. Insert the cable in to the cable gland and adjust it without the contact elements touching the braiding. Tighten the cap and conductivity will be established. The design of the contact elements will adapt to different cable diameters according to the clamping range of the cable glands. Since the clamping insert of the cable gland is as long as the gland itself electrical shortcuts between the body and individual wires will be avoided.

Tightening the dome nut will have three different effects: The cable will be centered in the cable gland, the choloprene seal will ensure IP 68 protection, and the design of the dome cap will provide appropriate strain relief. All is done by just one turn of the dome cap. Even uninstalling the cable is easy; open the dome cap and pull the cable out of the cable gland together with the insert, which can then be removed easily.



EMC 2 Cable Glands Brass

Installation instructions for EMC2 cable glands

In order to avoid electromagnetic interference EMC cable glands include a special EMC component that enlarges the contact with the cable shield . Assembly must be done by trained people only.

Under clamping pressure the outer sheath of a cable can shrink. We recommend to choosing cable glands whose lower clamping range is sufficiently smaller than the cable's outer dimension.

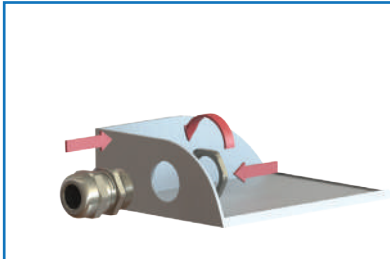

1. Install cable gland to the enclosure with the indicated "torque body". In order to increase contact quality EMC locknut utilization is recommended.

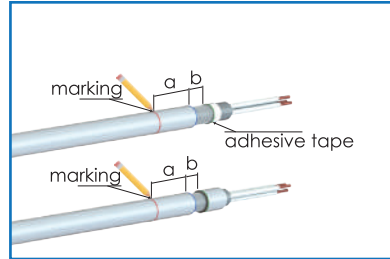

2. a. Remove the outer sheath of the cable carefully and don't cut into the shielding (braiding).
b. Use adhesive tape (preferred: adhesive copper band with conductive adhesive) or part of the outer sheath to protect the end part of the wires. See diagram above.
c. For required exposed length of shielding "b" please see diagram and table in products manual.
d. Mark dimension "a" on outer sheath accordingly. (See table.)

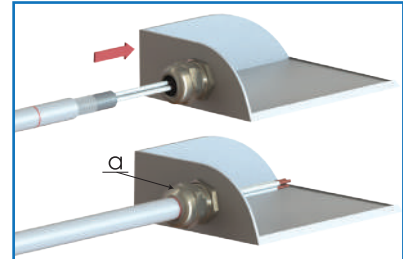

3. Insert cable into cable gland until marking "a" aligns with cap. EMC component will contact shielding .

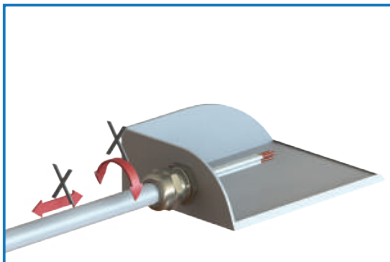

4. Do not pull or rotate cable after insertion. In doing so cable gland and shielding will be damaged.

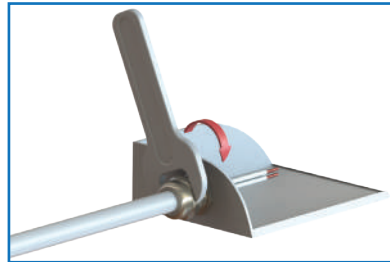

5. Tighten cap and apply indicated "torque cap".

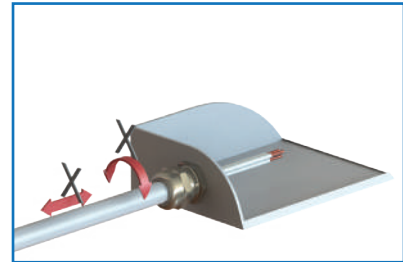



6. Do not pull or rotate cable after cap has been tightened. It will damage cable gland and shielding.

EMC 2 Cable Glands Brass

EMC cable glands with fixed spring contact

- Specially designed EMC protective cable glands.
- Long-lasting contact by high definition contact spring.
- Easy assembly: install cable gland - prepare cable sheath - insert cable - tighten cap.
- High quality strain relief and sealing reliable performance for EMC applications.

Technical Details	
Body, Cap	Brass Nickel plated
Seal	CR (Chloroprene)
Material	Clamping Insert PA 6 (Polyamide 6)
	Contact Spring Special Copper Alloy
	O-Ring NBR
Ingress Protection Rating	IP 68 - 5 Bar, 30 min
Flammability	V2 according to UL94
Operating Temperature	Permanent
	-20 °C to +100 °C
	Intermittent
	-40 °C to +150 °C
Thread Type	<ul style="list-style-type: none"> • Metric EN 60423 • PG DIN 40430 • NPT ANSI B1.20.1 • Other thread types also available upon request.
Cable Type	Shielded
Accessories	<ul style="list-style-type: none"> • EMC Lock nuts • Dome plugs • Gaskets (Washers)
Remarks	<ul style="list-style-type: none"> • Manufactured according to DIN EN 62444/50262. • We recommend the use of threaded holes and/or the use of special EMC lock nuts to ensure high quality EMC contact quality. • Some approvals do not cover all sizes. • O-ring available in Metric and PG threads as a standard. For NPT threads O-ring available upon request. • Accessories must be ordered separately. • Other lock nut types also available upon request.

Approvals	Certificate Number	Standards
	40039349	DIN EN 62444
	E199260	UL514B, CSA22.2 No 18.3-12, CSA22.2 No 94.2-15
TYPE 4x		UL50E
	E-14047	EN62444

For more approvals: see our webpage.



Thread Type METRIC acc. to EN 60423

Outer Thread Size (Male)	Clamping Range	Shield Diameter	Outer Thread Length	Spanner Width		Outer Ø	max. Height	Part Number	Minimum Order Quantity
				Cap	Body				
	Ø min-max mm	Ø min-max mm	TL mm	SW Cap mm	SW Body mm	D mm	H mm		
M12x1,5	3,0 - 6,5	2,5 - 4,5	6,0	14	14	15,5	24,0	BMEM-0S	1000
	3,0 - 6,5	2,5 - 4,5	12,0	14	14	15,5	24,0	BMEN-0S	1000
M16x1,5	4,0 - 8,0	3,5 - 6,0	7,0	17	18	20,0	25,5	BMEM-01	900
	4,0 - 8,0	3,5 - 6,0	12,0	17	18	20,0	25,5	BMEN-01	900
	5,0 - 10,0	4,0 - 8,0	6,5	20	20	22,0	31,5	BMEM-01S	600
M20x1,5	6,0 - 12,0	5,0 - 10,0	8,0	22	22	24,5	26,5	BMEM-02	500
	6,0 - 12,0	5,0 - 10,0	12,0	22	22	24,5	26,5	BMEN-02	500
M25x1,5	10,0 - 14,0	8,5 - 11,5	8,0	24	27	30,0	30,0	BMEM-03	350
	10,0 - 14,0	8,5 - 11,5	12,0	24	27	30,0	30,0	BMEN-03	350
	13,0 - 18,0	11,0 - 14,0	8,0	30	30	33,0	40,0	BMEM-03S	200
M32x1,5	13,0 - 18,0	11,0 - 14,0	9,0	30	34	37,5	35,0	BMEM-04	200
	13,0 - 18,0	11,0 - 14,0	15,0	30	34	37,5	35,0	BMEN-04	200
	18,0 - 25,0	16,0 - 20,0	9,0	40	40	44,5	46,0	BMEM-04S	100
M40x1,5	18,0 - 25,0	16,0 - 20,0	9,0	40	43	48,5	40,5	BMEM-05	100
	18,0 - 25,0	16,0 - 20,0	15,0	40	43	48,5	40,5	BMEN-05	100
	22,0 - 32,0	20,0 - 27,0	9,0	50	50	55,5	54,5	BMEM-05S	50
M50x1,5	22,0 - 32,0	20,0 - 27,0	9,0	50	55	61,0	50,0	BMEM-06	50
	22,0 - 32,0	20,0 - 27,0	15,0	50	55	61,0	50,0	BMEN-06	50
M63x1,5	34,0 - 44,0	31,0 - 40,0	14,0	64	68	75,0	55,0	BMEM-07	40
	34,0 - 44,0	31,0 - 40,0	18,0	64	68	75,0	55,0	BMEN-07	40

EMC 2 Cable Glands Brass

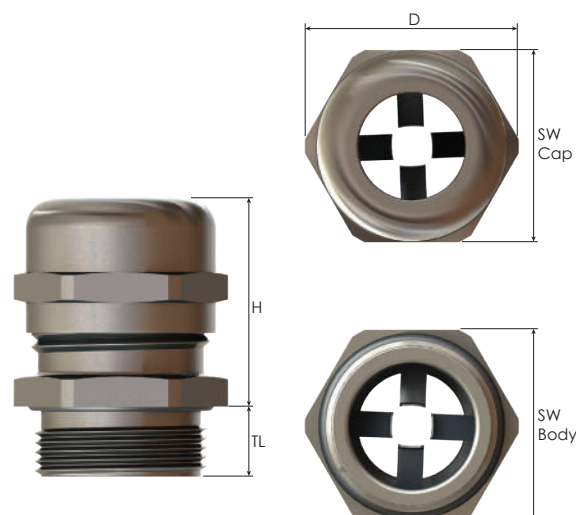

Thread Type NPT acc. to ANSI B1.20.1										
Outer Thread Size (Male)	Clamping Range Ø min-max mm	Shield Diameter Ø min-max mm	Outer Thread Length TL mm	Spanner Width Body		Outer Ø D mm	max. Height		Part Number	Minimum Order Quantity
				SW Cap mm	SW Body mm		H mm			
NPT 3/8"	5,0 - 10,0	4,0 - 8,0	11,5	20	20	22,0	31,5	BNEM-01	600	
NPT 1/2"	6,0 - 12,0	5,0 - 10,0	13,0	22	22	24,5	27,5	BNEM-02	500	
NPT 3/4"	13,0 - 18,0	11,0 - 14,0	13,0	30	30	33,0	38,0	BNEM-03	350	
NPT 1"	18,0 - 25,0	16,0 - 20,0	13,0	40	43	48,5	45,5	BNEM-04	200	

Thread Type PG acc. to DIN 40430										
Outer Thread Size (Male)	Clamping Range Ø min-max mm	Shield Diameter Ø min-max mm	Outer Thread Length TL mm	Spanner Width Body		Outer Ø D mm	max. Height		Part Number	Minimum Order Quantity
				SW Cap mm	SW Body mm		H mm			
PG 7	3,0 - 6,5	2,5 - 4,5	6,0	14	14	15,5	24,0	BSEM-01	1000	
	3,0 - 6,5	2,5 - 4,5	10,0	14	14	15,5	24,0	BSEN-01	1000	
PG 9	4,0 - 8,0	3,5 - 6,0	6,0	17	17	18,9	25,5	BSEM-02	900	
	4,0 - 8,0	3,5 - 6,0	10,0	17	17	18,9	25,5	BSEN-02	900	
PG 11	5,0 - 10,0	4,0 - 8,0	6,0	20	20	22,0	28,0	BSEM-03	600	
	5,0 - 10,0	4,0 - 8,0	10,0	20	20	22,0	28,0	BSEN-03	600	
PG 13,5	6,0 - 12,0	5,0 - 10,0	6,5	22	22	24,5	26,5	BSEM-04	500	
	6,0 - 12,0	5,0 - 10,0	10,0	22	22	24,5	26,5	BSEN-04	500	
PG 16	10,0 - 14,0	8,5 - 11,5	6,5	24	24	26,5	30,0	BSEM-05	400	
	10,0 - 14,0	8,5 - 11,5	10,0	24	24	26,5	30,0	BSEN-05	400	
PG 21	13,0 - 18,0	11,0 - 14,0	7,2	30	30	33,0	35,0	BSEM-06	200	
	13,0 - 18,0	11,0 - 14,0	12,0	30	30	33,0	35,0	BSEN-06	200	
PG 29	18,0 - 25,0	16,0 - 20,0	8,0	40	40	44,5	40,5	BSEM-07	100	
	18,0 - 25,0	16,0 - 20,0	12,0	40	40	44,5	40,5	BSEN-07	100	
PG 36	22,0 - 32,0	20,0 - 27,0	9,0	50	50	55,5	50,0	BSEM-08	50	
	22,0 - 32,0	20,0 - 27,0	14,0	50	50	55,5	50,0	BSEN-08	50	
PG 42	30,0 - 38,0	28,0 - 34,0	12,0	58	58	64,0	51,0	BSEM-09	40	
	30,0 - 38,0	28,0 - 34,0	16,0	58	58	64,0	51,0	BSEN-09	40	
PG 48	34,0 - 44,0	31,0 - 40,0	14,0	64	64	70,0	55,0	BSEM-10	40	
	34,0 - 44,0	31,0 - 40,0	18,0	64	64	70,0	55,0	BSEN-10	40	

Order Coding				
Part Number	- Gasket (Washer)		EMC Lock Nut	Sealing Plug
Mandatory	- Option		Option	Option
See table	- WC	Chloroprene	EL EMC Lock nut	P Dome Plug
	- WS	Silicone		T Dust Plug
Example				
BMEM-03	- WC		EL	P

EMC 3 Cable Glands Brass

The new generation of Bimed's EMC and derivation gland shows significant advantages compared to other existing cable glands. The patented contact system inside the gland allows all degrees of freedom which are necessary to install a cable easily; the cable can be pulled forward and backward inside the gland without damaging the cable shielding. This is realized by specially designed contact elements. This feature is most advantageous when connectorizing the single cores of the cable.

Also the cable can easily be rotated inside the gland without damaging the cable shielding – most important when installing the gland at an industrial connector. The unique mechanism of the integrated contact system therefore show the following features:

For small cable diameters in the lower clamping range of the gland the contact system won't touch the cable braiding during the installation process at all. For bigger cable diameters in the upper clamping range of the gland, the contact system will rotate freely inside the gland together with the cable itself. Only when tightening the cap the contact element will be fixed and will be pressed against the cable shielding to ensure a low resistance electrical contact between gland and cable braiding. Simultaneously IP68 protection class and cable anchorage according to the EN 62444 is achieved.

This straight forward application and convenient installation of the gland saves a lot of time and therefore a lot of money. Shielding and derivation tests performed with this gland show exceptional values. So this EMC and derivation gland from Bimed will be used wherever an outstanding performance is needed. Simple application, fast installation together with the patented contact system makes Bimed's gland unique among the cable glands

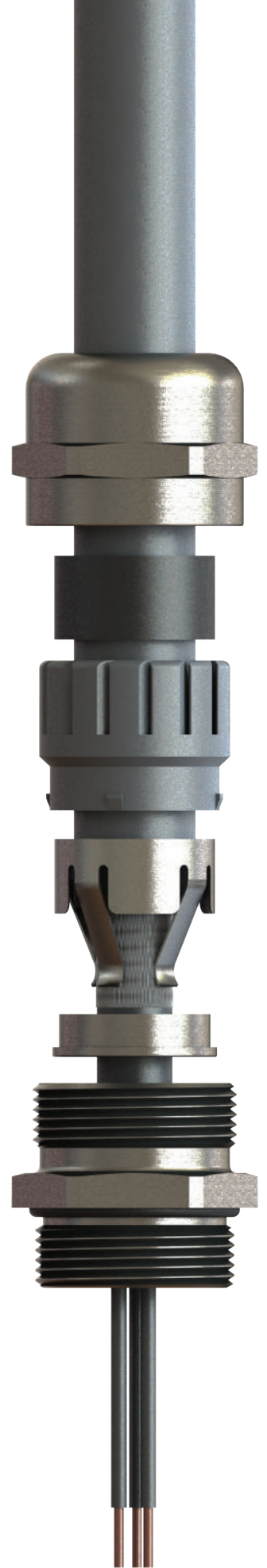

EMC 3 Cable Glands Brass

Installation instructions for EMC3 cable glands

In order to avoid electromagnetic interference EMC cable glands include a special EMC component that enlarges the contact with the cable shield. Assembly must be done by trained people only.

Under clamping pressure the outer sheath of a cable can shrink. We recommend to choose cable glands whose lower clamping range is sufficiently smaller than the cable's outer dimension.

The shield diameter must fit.

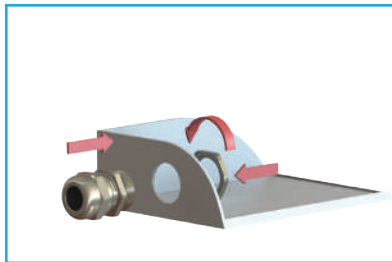

1. Install cable gland to the enclosure with the indicated "torque body". In order to increase contact quality EMC locknut utilization is recommended.

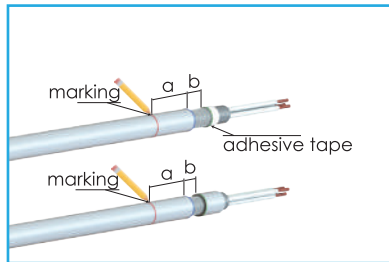

2. a. Remove the outer sheath of the cable carefully and don't cut into the shielding (braiding).
b. Use adhesive tape (preferred: adhesive copper band with conductive adhesive) or part of the outer sheath to protect the end part of the wires. See diagram above.
c. For required exposed length of shielding "b" please see diagram and table in products manual.
d. Mark dimension "a" on outer sheath accordingly. (See table.)

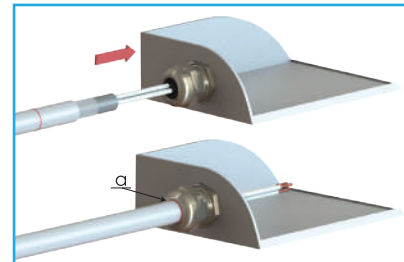

3. Insert cable into cable gland until marking "a" aligns with cap.

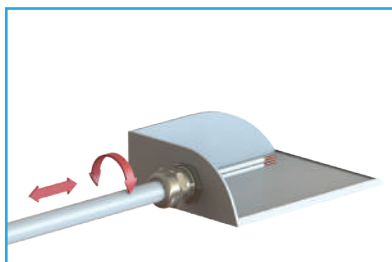

4. Do not pull or rotate cable after insertion if no adhesive copper tape is used (2b). Otherwise cable gland and shielding could be damaged.

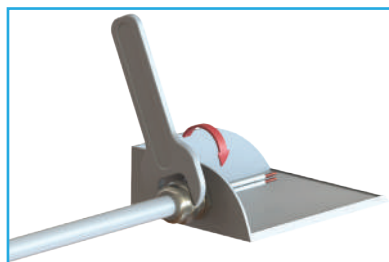

5. Tighten cap and apply indicated "torque cap". EMC component will contact shielding.

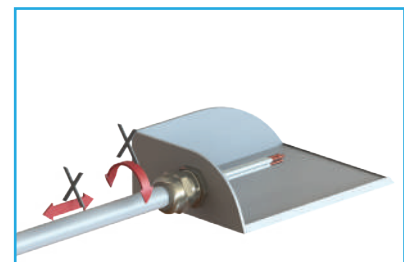

6. Do not pull or rotate cable after cap has been tightened. It will damage cable gland and shielding.



EMC 3 Cable Glands Brass

EMC cable glands with moving spring contact

- Specially designed EMC protective cable glands.
- Long-lasting contact by high definition contact spring.
- Moving spring contact offers reduced risk of sheath damage.
- Easy assembly: install cable gland - prepare cable sheath - insert cable - tighten cap.
- High quality strain relief and sealing, reliable performance for EMC applications.
- Up-to-date international approvals.

Technical Details		
Body, Cap	Brass Nickel plated	
Seal	CR (Chloroprene)	
Material	Clamping Insert PA 6 (Polyamide 6)	
	Contact Spring Special Copper Alloy	
	O-Ring NBR	
Ingress Protection Rating	IP 68 - 5 Bar, 30 min	
Flammability	V2 according to UL94	
Operating Temperature	Permanent	Intermittent
	-20 °C to +100 °C	-40 °C to +150 °C
Thread Type	<ul style="list-style-type: none"> • Metric EN 60423 • Other thread types also available upon request. 	
Cable Type	Shielded	
Accessories	<ul style="list-style-type: none"> • EMC Lock nuts • Dome plugs • Gaskets (Washers) 	

- Remarks**
- Manufactured according to DIN EN 62444/50262.
 - We recommend the use of lock nuts and gaskets to ensure IP rating for rough surfaces or through holes.
 - Some approvals do not cover all sizes.
 - O-ring available in Metric and PG threads as a standard. For NPT threads O-ring available upon request.
 - Accessories must be ordered separately.
 - Other lock nut types also available upon request.

Approvals	Certificate Number	Standards
	40039349	DIN EN 62444
	E199260	UL514B, CSA22.2 No 18.3-12, CSA22.2 No 94.2-15
TYPE 4x		UL50E
	E-14047	EN62444

For more approvals: see our webpage.

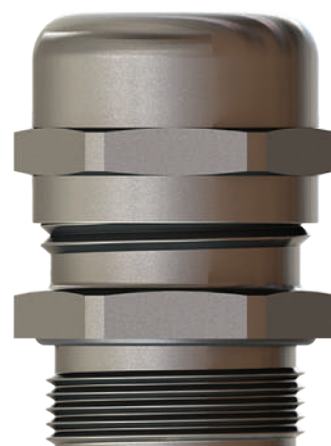

Order Coding				
Part Number	-	Gasket (Washer)	EMC Lock Nut	Sealing Plug
Mandatory	-	Option	Option	Option
See table	-	WC Chloroprene WS Silicone	EL EMC Lock Nut	P Dome Plug T Dust Plug
Example				
BMEM-E2	-	WC	EL	P

EMC 3 Cable Glands Brass

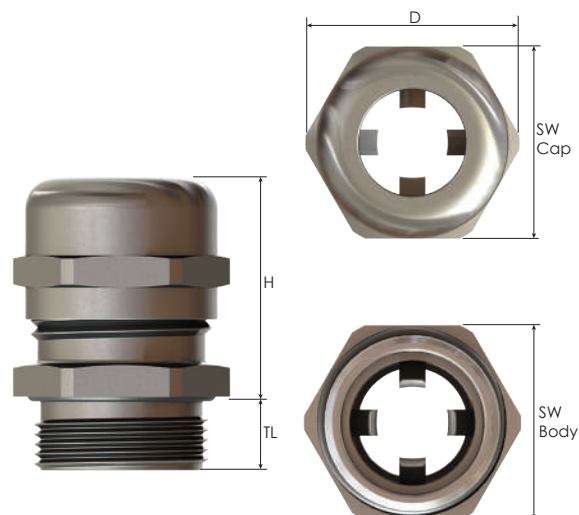

Thread Type **METRIC** acc. to EN 60423

Outer Thread Size (Male)	Clamping Range Ø min-max mm	Shield Diameter Ø min-max mm	Outer Thread Length TL mm	Spanner Width		Outer Ø D mm	max. Height H mm	Part Number	Minimum Order Quantity
				Cap SW Cap mm	Body SW Body mm				
M12x1,5	3,0 - 6,5	2,5 - 4,5	6,0	14	14	15,5	24,0	BMEM-E5	1000
M16x1,5	5,0 - 10,0	4,0 - 8,0	7,0	20	20	22,0	32,0	BMEM-E1	600
M20x1,5	6,0 - 12,0	5,0 - 10,0	8,0	22	22	24,5	29,5	BMEM-E2	500
M25x1,5	11,0 - 17,0	9,5 - 15,0	8,0	27	27	30,0	33,5	BMEM-E3	350
M32x1,5	15,0 - 21,0	13,5 - 19,0	8,0	34	34	37,5	38,0	BMEM-E4	200
M40x1,5	19,0 - 28,0	17,0 - 25,0	9,0	43	43	48,5	48,0	BMEM-E5	100
M50x1,5	27,0 - 38,0	25,0 - 32,0	9,0	58	58	64,0	56,0	BMEM-E6	40
M63x1,5	34,0 - 44,0	31,0 - 41,0	14,0	64	68	75,0	59,5	BMEM-E7	40

EMC 4 Cable Glands Brass

These cable glands are developed according to end users' requirements. Their features can be summarized as follows:

- Easy insertion of the cable from the two sides of the gland.
- Open contact fingers in loose position.
- Free radial and axial movement of the cable.
- Easy radial and axial movement of the cable, even in contact position without any damage to the braid with the help of rounded contact finger surfaces.
- Large contact surfaces of the fingers allow low contact resistance even on loosely woven cable braids (the contact surfaces do not sink into the braided wires).
- High contact performance even under vibrating conditions with help of the reduced distance between the "sealing clamping level" and "EMC contact level".

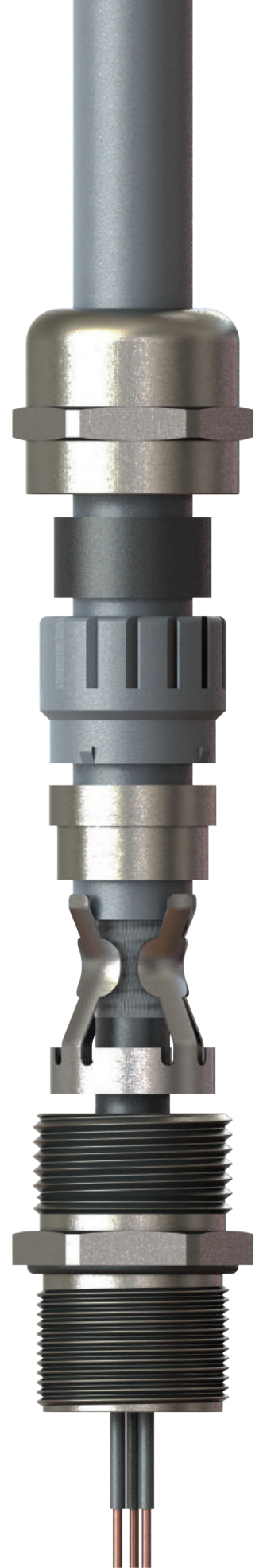
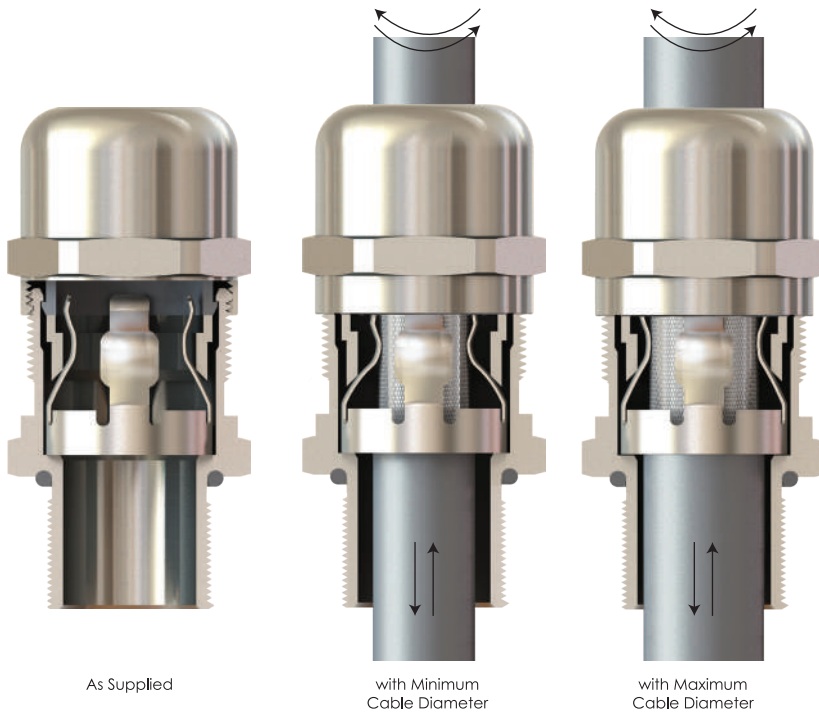

EMC 4 Cable Glands Brass

Installation instructions for EMC4 cable glands

In order to avoid electromagnetic interference EMC cable glands include a special EMC component that enlarges the contact with the cable shield. Assembly must be done by trained people only.

Under clamping pressure the outer sheath of a cable can shrink. We recommend to choose cable glands whose lower clamping range is sufficiently smaller than the cable's outer dimension.

The shield diameter must fit.

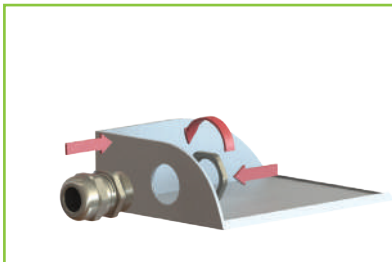

1. Install cable gland to the enclosure with the indicated "torque body". In order to increase contact quality EMC locknut utilization is recommended.

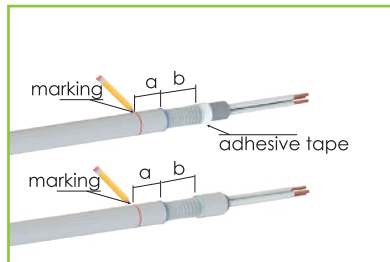

2. a. Remove the outer sheath of the cable carefully and don't cut into the shielding (braiding).
b. Use adhesive tape (preferred: adhesive copper band with conductive adhesive) or part of the outer sheath to protect the end part of the wires. See diagram above.
c. For required exposed length of shielding "b" please see diagram and table in products manual.
d. Mark dimension "a" on outer sheath accordingly. (See table.)

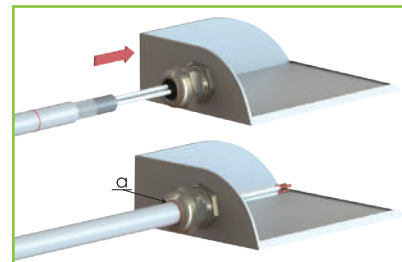

3. Insert cable into cable gland until marking "a" aligns with cap.

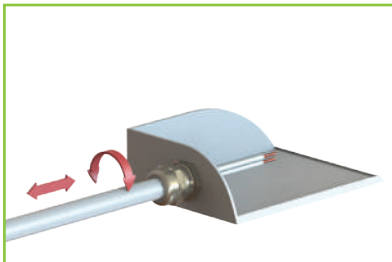

4. As long as the cap is not tightened, you can easily pull push or rotate the cable.

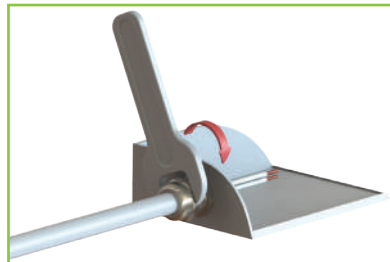

5. Tighten cap and apply indicated "torque cap". EMC component will contact shielding.

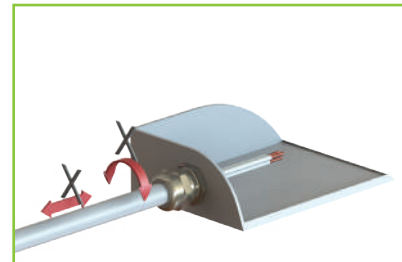

6. Do not pull or rotate cable after cap has been tightened. It will damage cable gland and shielding.

EMC 4 Cable Glands Brass



Brass cable gland for EMC

- Vibration proof EMC performance.
- Long-lasting contact by high definition contact spring.
- Moving spring contact offers reduced risk of sheath damage.
- Easy assembly and disassembly of cable. Spring closes and opens according to fastening of the cap.
- Easy movement of cable as long as not fastened.
- High quality strain relief and sealing, reliable performance for EMC applications.
- Up-to-date international approvals.

Technical Details

Material	Body, Cap	Brass Nickel plated	
	Seal	CR (Chloroprene)	
	Clamping Insert	PA 6 (Polyamide 6)	
	Contact Spring	Special Copper Alloy	
	O-Ring	NBR	
Ingress Protection Rating	IP 68 - 5 Bar, 30 min		
Flammability	V2 according to UL94		
Operating Temperature	Permanent	-20 °C to +100 °C	Intermittent
			-40 °C to +150 °C
Thread Type	<ul style="list-style-type: none"> • Metric EN 60423 • PG DIN 40430 • NPT ANSI B1.20.1 • Other thread types also available upon request. 		
Cable Type	Shielded		
Accessories	<ul style="list-style-type: none"> • EMC Lock nuts • Dome plugs • Gaskets (Washers) 		

- Remarks**
- Manufactured according to DIN EN 62444/50262.
 - We recommend the use of lock nuts and gaskets to ensure IP rating for rough surfaces or through holes.
 - Some approvals do not cover all sizes.
 - O-ring available in Metric and PG threads as a standard. For NPT threads O-ring available upon request.
 - Accessories must be ordered separately.
 - Other lock nut types also available upon request.

Approvals	Certificate Number	Standards
	40039349	DIN EN 62444
	E-199260	UL514B CSA22.2 No 18.3-12 CSA22.2 No 94.2-1S
TYPE 4x		UL50E
	E-14047	EN62444

For more approvals: see our webpage.

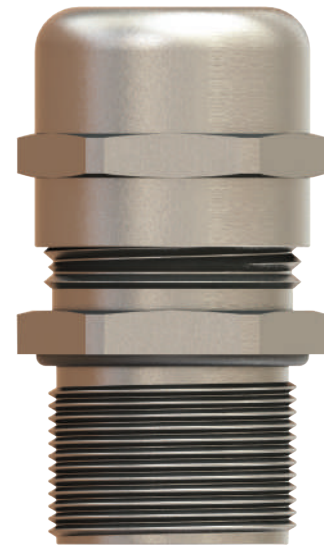

Order Coding				
Part Number	-	Gasket (Washer)	EMC Lock Nut	Sealing Plug
Mandatory	-	Option	Option	Option
See table	-	WC Chloroprene WS Silicone	EL Lock nut	P Dome Plug T Dust Plug
Example				
BMEM-E6(M50T)	-	WC	EL	P

EMC 4 Cable Glands Brass

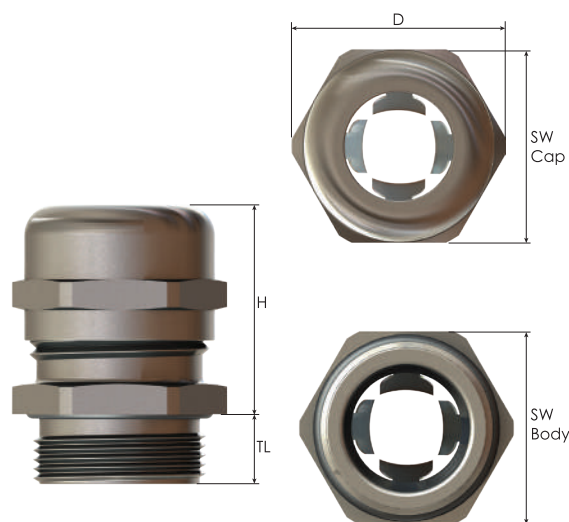

Thread Type **METRIC** acc. to EN 60423

Outer Thread Size (Male)	Clamping Range Ø min-max mm	Shield Diameter Ø min-max mm	Outer Thread Length TL mm	Spanner Width		Outer Ø D mm	max. Height H mm	Part Number	Minimum Order Quantity
				Cap SW Cap mm	Body SW Body mm				
M12x1,5	3,0 - 6,5	2,0 - 5,0	6,0	14	14	15,5	30,0	BMEM-ES(M12T)	1000
M16x1,5	5,0 - 10,0	3,5 - 8,0	6,0	20	20	22,0	35,0	BMEM-E1(M16T)	600
M20x1,5	6,0 - 12,0	4,5 - 10,0	6,0	22	22	24,5	33,5	BMEM-E2S(M20T)	500
	7,5 - 14,0	5,5 - 11,5	8,0	24	24	26,8	41,5	BMEM-E2(M20T)	350
M25x1,5	10,0 - 18,0	7,0 - 14,0	8,0	30	30	33,0	44,5	BMEM-E3(M25T)	200
M32x1,5	16,0 - 25,0	12,0 - 20,0	9,0	40	40	44,5	55,0	BMEM-E4(M32T)	100
M40x1,5	22,0 - 32,0	18,0 - 27,0	9,0	50	50	55,5	62,5	BMEM-E5(M40T)	50
M50x1,5	30,0 - 38,0	26,0 - 34,0	9,0	58	58	64,0	74,0	BMEM-E6(M50T)	40
	34,0 - 44,0	30,0 - 40,0	14,0	64	68	75,0	60,0	BMEM-E7(M63T)	40
M63x1,5	37,0 - 53,0	33,0 - 49,0	10,0	75	75	83,0	75,0	BMEM-E7L(M63T)	20

Thread Type **NPT** acc. to ANSI B1.20.1

Outer Thread Size (Male)	Clamping Range Ø min-max mm	Shield Diameter Ø min-max mm	Outer Thread Length TL mm	Spanner Width		Outer Ø D mm	max. Height H mm	Part Number	Minimum Order Quantity
				Cap SW Cap mm	Body SW Body mm				
NPT 1/4"	3,0 - 6,5	2,0 - 5,0	11,5	14	15	16,5	30,0	BNEM-ES(NPT1/4"T)	1000
NPT 3/8"	5,0 - 10,0	3,5 - 8,0	11,5	20	20	22,0	35,0	BNEM-E1(NPT3/8"T)	600
NPT 1/2"	6,0 - 12,0	4,5 - 10,0	15,0	22	22	24,5	39,5	BNEM-E2S(NPT1/2"T)	500
	7,5 - 14,0	5,5 - 11,5	15,0	24	24	26,8	41,5	BNEM-E2(NPT1/2"T)	350
NPT 3/4"	10,0 - 18,0	7,0 - 14,0	15,0	30	30	33,0	43,5	BNEM-E3(NPT3/4"T)	200
NPT 1"	16,0 - 25,0	12,0 - 20,0	20,0	40	40	44,5	54,0	BNEM-E4(NPT1"T)	100
NPT 1 1/4"	22,0 - 32,0	18,0 - 27,0	20,0	50	50	55,5	63,0	BNEM-E5(NPT1 1/4"T)	50
NPT 1 1/2"	30,0 - 38,0	26,0 - 34,0	22,0	58	58	64,0	73,0	BNEM-E6(NPT1 1/2"T)	40
NPT 2"	34,0 - 44,0	30,0 - 40,0	22,0	64	68	75,0	73,0	BNEM-E7(NPT2"T)	40

Thread Type **PG** acc. to DIN 40430

Outer Thread Size (Male)	Clamping Range Ø min-max mm	Shield Diameter Ø min-max mm	Outer Thread Length TL mm	Spanner Width		Outer Ø D mm	max. Height H mm	Part Number	Minimum Order Quantity
				Cap SW Cap mm	Body SW Body mm				
PG 7	3,0 - 6,5	2,0 - 5,0	6,0	14	15	16,5	30,0	BSEM-E1(PG7T)	1000
PG 11	5,0 - 10,0	3,5 - 8,0	6,0	20	21	23,0	35,0	BSEM-E3(PG11T)	600
PG 13,5	6,0 - 12,0	4,5 - 10,0	6,5	22	22	24,5	33,5	BSEM-E4(PG13,5T)	500
PG 16	7,5 - 14,0	5,5 - 11,5	6,5	24	25	27,5	41,5	BSEM-E5(PG16T)	350
PG 21	10,0 - 18,0	7,0 - 14,0	7,0	30	32	35,5	44,5	BSEM-E6(PG21T)	200
PG 29	16,0 - 25,0	12,0 - 20,0	9,0	40	40	44,5	55,0	BSEM-E7(PG29T)	100
PG 36	22,0 - 32,0	18,0 - 27,0	9,0	50	50	55,5	62,0	BSEM-E8(PG36T)	50
PG 42	30,0 - 38,0	26,0 - 34,0	12,0	58	60	66,5	74,5	BSEM-E9(PG42T)	40
PG 48	34,0 - 44,0	30,0 - 40,0	14,0	64	68	75,0	60,5	BSEM-E10(PG48T)	40

Snap-In Cable Glands, EMC 4, Brass

EMC cable glands with open moving spring contact, front-side assembly, without thread

- Specially designed EMC protective cable glands - easy to assemble to housings without threaded holes.
- Vibration proof EMC performance.
- Long-lasting contact by high definition contact spring.
- Moving spring contact offers reduced risk of sheath damage.
- Easy assembly and disassembly of cable. Spring closes and opens according to fastening of the cap.
- Easy movement of cable as long as not fastened.
- Easy assembly: push cable gland and turn body clockwise - prepare cable sheath - insert cable - tighten cap.
- Perfectly fit to wall thickness 0,5 mm to 4,0 mm.
- High quality strain relief and sealing, reliable performance for EMC applications.

Technical Details

Material	Body, Cap	Brass Nickel plated	
	Seal	CR (Chloroprene)	
	Gasket	CR (Chloroprene)	
	Clamping Insert	PA 6 (Polyamide 6)	
	Lower Body	PA 6 (Polyamide 6)	
	Contact Spring	Special Copper Alloy	
Ingress Protection Rating		IP 68 - 5 Bar, 30 min	
		IP 66	
Flammability	V2 according to UL94		
Operating Temperature	Permanent	-20 °C to +100 °C	
	Intermittent	-40 °C to +150 °C	
Cable Type	Shielded		
Accessories	<ul style="list-style-type: none"> • Dome plugs • Disassembly tool (one piece included per Minimum Order Quantity) 		
Remarks	<ul style="list-style-type: none"> • Manufactured according to DIN EN 62444/50262. • Accessories must be ordered separately. 		
Approvals	Certificate Number	Standards	
	SERCOVAM RES 107572	acc. to UL514B §8.26.7	



Assembling

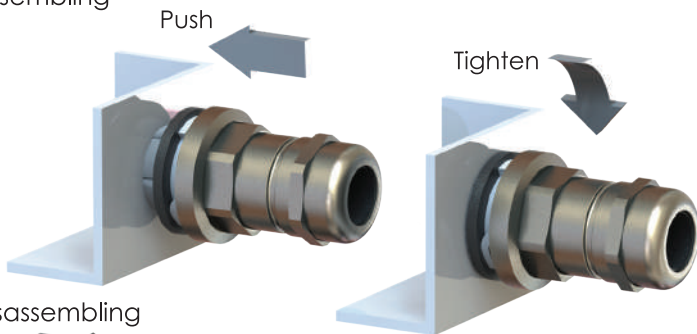

Disassembling

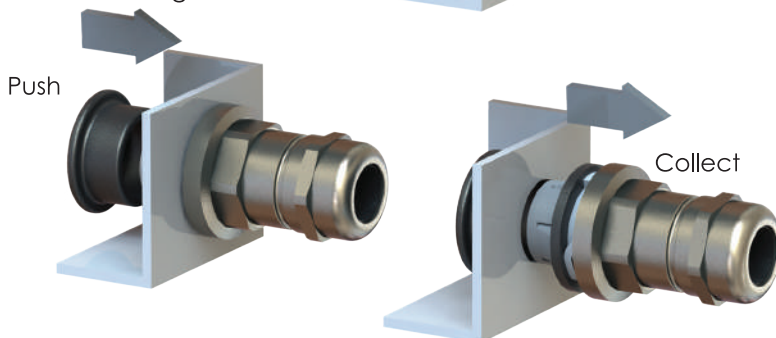

Snap-In Cable Glands, EMC 4 Brass

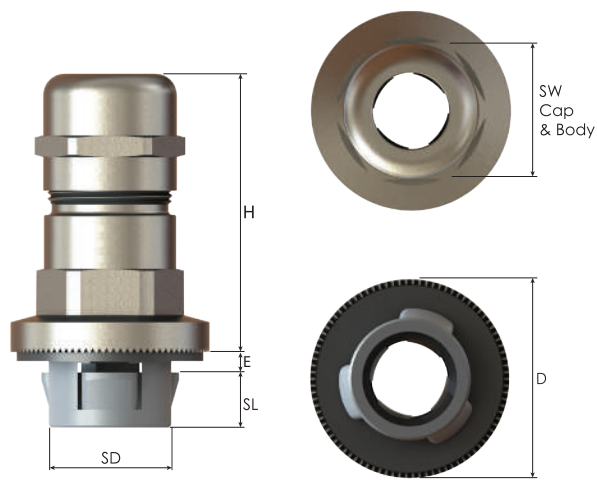

wall thickness (E) : 0,5 - 4,0 mm

Snap Size	Clamping Range Ø min-max mm	Shield Diameter Ø min-max mm	Snap Length		Enclosure Hole Ø HD mm	Spanner Width		Outer Ø D mm	max. Height H mm	Part Number	Minimum Order Quantity
			SL mm	SD mm		Cap mm	Body mm				
20	6,0 - 12,0	4,5 - 10,0	9,0	19,9	20,2 - 20,4	22	22	32,3	52,5	BMEOS-E2S(T)	150

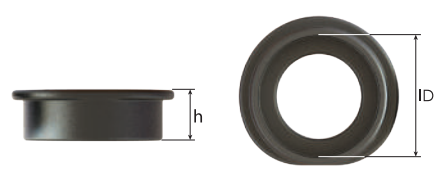
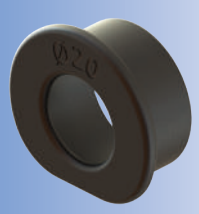

Snap-In Cable Gland Disassembling Tool

Tool to disassemble Snap-In Glands	
Technical Details	
Material	PA 6 (Polyamide 6)

For Gland Size	Inner Ø ID mm	Height h mm	Part Number
20	20,0	13,0	BEX-20

Cable Protection Glands, EMC 2, Brass

EMC cable protection glands with lamellar clamping

- For cable bending protection.
- Specially designed EMC protective cable glands.
- Long-lasting contact by high definition contact spring.
- Easy assembly: install cable gland - prepare cable sheath - insert cable - tighten cap.
- High quality strain relief and sealing, reliable performance for EMC applications.

Technical Details

Material	Cable Gland	Brass, Nickel plated	
	Sealing	CR (Chloroprene), NBR	
	Clamping Insert	PA 6 (Polyamide 6)	
	Bending Spiral	Stainless steel (AISI 301)	
	O-ring	NBR	
	Contact Spring	Special Copper Alloy	
Ingress Protection Rating	IP 68 - 5 Bar, 30 min		
Flammability	V2 according to UL94		
Operating Temperature	Permanent	-20 °C to +100 °C	
	Intermittent	-40 °C to +150 °C	
Thread Type	<ul style="list-style-type: none"> • Metric EN 60423 • Other thread types also available upon request. 		
Cable Type	Shielded		
Accessories	<ul style="list-style-type: none"> • Lock nuts • Gaskets (Washers) 		
	<ul style="list-style-type: none"> • Manufactured according to DIN EN 62444/50262. • We recommend the use of lock nuts and gaskets to ensure IP rating for rough surfaces or through holes. • Accessories must be ordered separately. 		
Remarks			



Cable Protection Glands, EMC 2, Brass

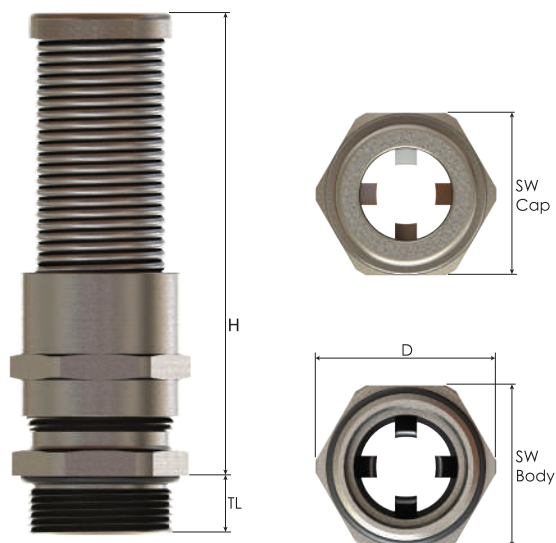

Thread Type **METRIC** acc. to EN 60423

Outer Thread Size (Male)	Clamping Range Ø min-max mm	Shield Ø Ø min-max mm	Outer Thread Length TL mm	Spanner Width		Outer Ø D mm	max. Height H mm	Part Number	Minimum Order Quantity
				Cap mm	Body mm				
M16x1,5	5,0 - 10,0	4,0 - 8,0	7,0	20	20	22,0	76,0	BMEMSP-E1	300
M20x1,5	6,0 - 12,0	5,0 - 10,0	8,0	22	22	24,5	68,0	BMEMSP-E2	200
M25x1,5	11,0 - 17,0	9,5 - 15,0	8,0	27	27	30,0	74,5	BMEMSP-E3	150

Metal CABLE GLANDS for Railway Applications



Glands

Octans Cable Glands for Railway Applications, Brass
Standard Cable Glands for Railway Applications, Brass
EMC 4 Cable Glands for Railway Applications, Brass

60 - 61
62 - 63
64 - 65

Polyamide CABLE GLANDS for Railway Applications



Glands

Standard Cable Glands for Railway Applications, Polyamide

66 - 67

Octans Cable Glands for Railway Application, Brass

Brass railway cable glands with lamellar clamping

- For railway applications.
- Prevents damages according to pressure differences.
- Easy assembly.
- High quality strain relief and sealing, reliable performance for standard industrial applications.
- Up-to-date international approvals.

Technical Details

Material	Body, Cap	Brass, Brass Nickel Plated
	Seal	EPDM
	O-ring	EPDM
Ingress Protection Rating	IP 68 - 5 Bar, 30 min IP 66	
Flammability	R22 acc. to EN45545-2 R23 acc. to EN45545-2 HL2 acc. to EN45545-2 HL3 acc. to EN45545-2	
Approvals	<ul style="list-style-type: none"> • The sealing material of the products has CURRENTA Approval in conformity with EN 45545-3. 	
Operating Temperature	Seal Material	
	Permanent -50°C to +125°C	
Thread Type	Metric (M) EN 60423 NPT (N) ANSI ASME B1.20.1	
Accessories	<ul style="list-style-type: none"> • Lock nuts 	
Remarks	<ul style="list-style-type: none"> • We recommend the use of lock nuts and gaskets to ensure IP rating for rough surfaces or through holes. • Accessories must be ordered separately. 	

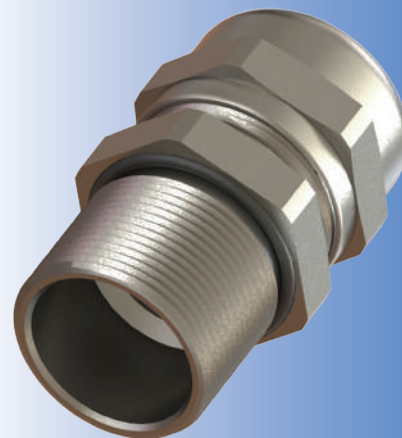

Order Coding		
Part Number	-	Lock Nut
Mandatory	-	Option
See table	-	L Lock nut
Example		
R-BU2MBNE	-	L

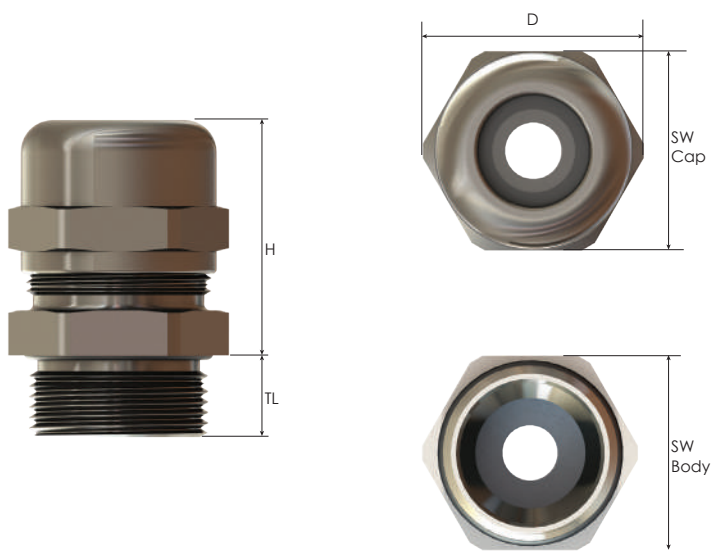

Octans Cable Glands for Railway Application, Brass

Thread Type **METRIC** acc. to EN 60423

Outer Thread Size (Male)	Clamping Range		Outer Thread Length TL mm	Spanner Width		Outer Ø D mm	max. Height		Part Number	Minimum Order Quantity
	Ø min-max mm	Seal Type		SW Cap mm	SW Body mm		H mm			
M20x1,5	4,0 - 12,0	Triple	9,0	22	22	24,5	29,0	R-BU1MBNE	189	
	10,0 - 16,0	Triple	9,0	28	28	31,0	32,0	R-BU12MBNE	105	
M25x1,5	4,0 - 12,0	Triple	9,0	22	28	31,0	29,0	R-BU2SMBNE	105	
	10,0 - 18,0	Triple	9,0	28	28	31,0	32,5	R-BU2MBNE	105	
M32x1,5	10,0 - 18,0	Triple	9,0	28	35	39,0	32,5	R-BU3SMBNE	70	
	14,0 - 24,0	Triple	9,0	35	35	39,0	35,0	R-BU3MBNE	70	
	22,0 - 28,0	Triple	9,0	45	45	49,5	42,5	R-BU34MBNE	40	
M40x1,5	14,0 - 24,0	Triple	9,0	35	45	49,5	35,0	R-BU4SMBNE	40	
	22,0 - 32,0	Triple	9,0	45	45	49,5	42,5	R-BU4MBNE	40	
M50x1,5	26,0 - 35,0	Triple	9,0	50	55	61,0	45,5	R-BU5MBNE	24	
	35,0 - 44,0	Triple	9,0	64	64	70,0	45,0	R-BU56MBNE	24	

Standard Cable Glands for Railway Application, Brass

Brass railway cable glands with lamellar clamping

- For railway applications.
- Prevents damages according to pressure differences.
- Easy assembly.
- High quality strain relief and sealing, reliable performance for standard industrial applications.

Technical Details

Material	Body, Cap	Brass, Brass Nickel Plated
	Seal	EPDM
	Clamping Insert	PA 6 (Polyamide 6)
	O-ring	EPDM
Ingress Protection Rating		IP 68 - 5 Bar, 30 min
		IP 66
Flammability		R22 acc. to EN45545-2
		R23 acc. to EN45545-2
		HL2 acc. to EN45545-2
		HL3 acc. to EN45545-2
Approvals		• The sealing material of the products has CURRENTA Approval in conformity with EN 45545-3.
		Seal Material
Operating Temperature		Permanent
		-40°C to +100°C
Thread Type		Metric (M) EN 60423
		NPT (N) ANSI ASME B1.20.1
Accessories		• Lock nuts
Remarks		• We recommend the use of lock nuts and gaskets to ensure IP rating for rough surfaces or through holes.
		• Accessories must be ordered separately.



Order Coding		
Part Number	-	Lock Nut
Mandatory	-	Option
See table	-	L Lock nut
Example		
R-BMBC-E2	-	L

Standard Cable Glands for Railway Application

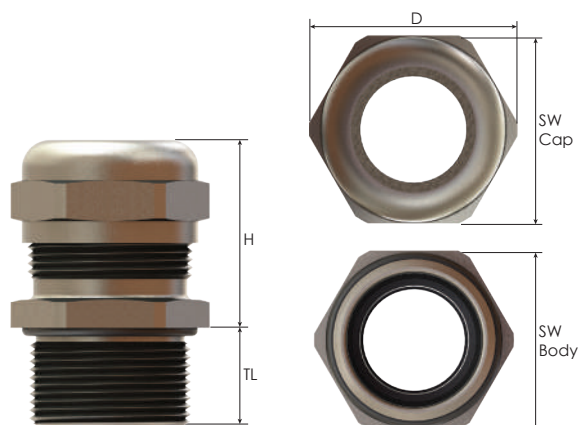

Thread Type **METRIC** acc. to EN 60423

Outer Thread Size (Male)	Clamping Range Ø min-max mm	Outer Thread Length TL mm	Spanner Width		Outer Ø D mm	max. Height H mm		Part Number	Minimum Order Quantity
			Cap SW Cap mm	Body SW Body mm					
M12x1,5	3,0 - 6,5	6,0	14	14	15,5	24,0	R-BMBC-ES	600	
	3,0 - 6,5	12,0	14	14	15,5	24,0	R-BMBE-ES	600	
M16x1,5	4,0 - 8,0	7,0	17	18	20,0	25,5	R-BMBC-01	600	
	4,0 - 8,0	12,0	17	18	20,0	25,5	R-BMBE-01	600	
	5,0 - 10,0	7,0	20	20	22,0	30,5	R-BMBC-E1	600	
	5,0 - 10,0	12,0	20	20	22,0	30,5	R-BMBE-E1	600	
M20x1,5	6,0 - 12,0	8,0	22	22	24,5	28,0	R-BMBC-E2	300	
	6,0 - 12,0	12,0	22	22	24,5	28,0	R-BMBE-E2	300	
	10,0 - 14,0	8,0	24	24	26,5	30,0	R-BMBC-02S	300	
	10,0 - 14,0	12,0	24	24	26,5	30,0	R-BMBE-02S	300	
M25x1,5	13,0 - 18,0	8,0	30	30	33,0	35,0	R-BMBC-03S	180	
	13,0 - 18,0	12,0	30	30	33,0	35,0	R-BMBE-03S	180	
M32x1,5	18,0 - 25,0	9,0	40	40	44,5	46,0	R-BMBC-04S	60	
	18,0 - 25,0	15,0	40	40	44,5	46,0	R-BMBE-04S	60	
M40x1,5	22,0 - 32,0	9,0	50	50	55,5	54,5	R-BMBC-05S	50	
	22,0 - 32,0	15,0	50	50	55,5	54,5	R-BMBE-05S	50	

Cable Glands for Railway Applications, EMC 4, Brass

EMC 4 railway cable glands with lamellar clamping

- For railway applications.
- Vibration proof EMC performance.
- Long-lasting contact by high definition contact spring.
- Moving spring contact offers reduced risk of sheath damage.
- Easy assembly and disassembly of cable. Spring closes and opens according to fastening of the cap.
- Easy movement of cable as long as not fastened.
- High quality strain relief and sealing, reliable performance for EMC applications.
- Up-to-date international approvals.

Technical Details

	Body, Cap	Brass, Brass Nickel Plated
	Seal	EPDM
Material	Clamping Insert	PA 6 (Polyamide 6)
	Contact Spring	Special Copper Alloy
	O-ring	EPDM
Ingress Protection Rating		IP 68 - 5 Bar, 30 min
		IP 66
Flammability		R22 acc. to EN45545-2
		R23 acc. to EN45545-2
		HL2 acc. to EN45545-2
		HL3 acc. to EN45545-2
Approvals		• The raw material of the products has CURRENTA Approval in conformity with EN 45545-3.
		Seal Material
Operating Temperature		Permanent
		-40°C to +100°C
Thread Type		Metric (M) EN 60423
		NPT (N) ANSI ASME B1.20.1
Accessories		• Lock nuts
Remarks		• We recommend the use of lock nuts and gaskets to ensure IP rating for rough surfaces or through holes.
		• Accessories must be ordered separately.

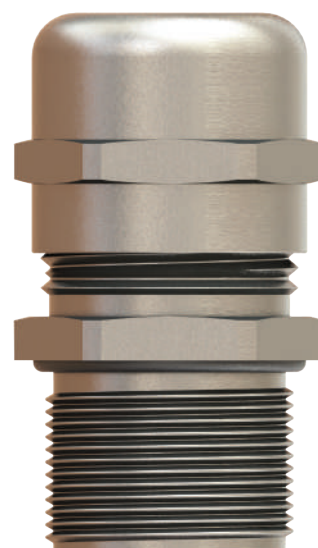

Order Coding			
Part Number	-	Gasket (Washer)	Lock Nut
Mandatory	-	Option	Option
See table	-	WC Chloroprene WS Silicone	L Lock nut
Example			
R-BMEM-E2S (M20T)	-	WC	L

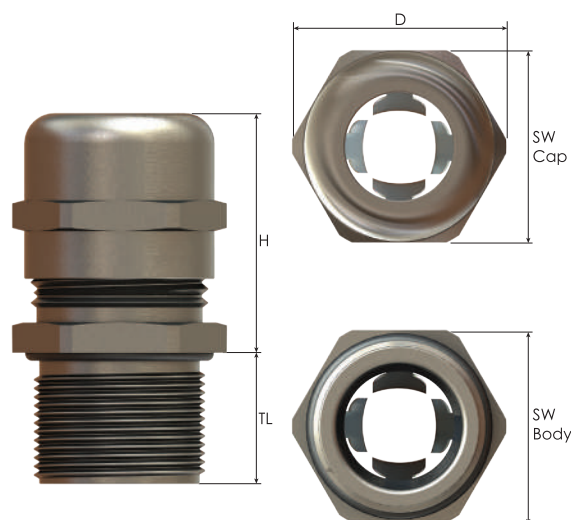

Cable Glands for Railway Applications, EMC 4, Brass

Thread Type **METRIC** acc. to EN 60423

Outer Thread Size (Male)	Clamping Range Ø min-max mm	Shield Diameter Ø min-max mm	Outer Thread Length TL mm	Spanner Width		Outer Ø		max. Height		Part Number	Minimum Order Quantity
				Cap SW Cap mm	Body SW Body mm	D mm	H mm				
M12x1,5	3,0 - 6,5	2,0 - 5,0	6,0	14	14	15,5	30,0	R-BMEM-ES (M12T)	600		
M16x1,5	5,0 - 10,0	3,5 - 8,0	6,0	20	20	22,0	35,0	R-BMEM-E1 (M16T)	600		
M20x1,5	6,0 - 12,0	4,5 - 10,0	6,0	22	22	24,5	33,5	R-BMEM-E2S (M20T)	300		
	7,5 - 14,0	5,5 - 11,5	8,0	24	24	26,8	41,5	R-BMEM-E2 (M20T)	300		
M25x1,5	10,0 - 18,0	7,0 - 14,0	8,0	30	30	33,0	44,5	R-BMEM-E3 (M25T)	180		
M32x1,5	16,0 - 25,0	12,0 - 20,0	9,0	40	40	44,5	55,0	R-BMEM-E4 (M32T)	60		
M40x1,5	22,0 - 32,0	18,0 - 27,0	9,0	50	50	55,5	62,5	R-BMEM-E5 (M40T)	50		

Standard Cable Glands for Railway Applications, Polyamide

Polyamide cable glands for railway application

- For standard industrial applications.
- Easy assembly.
- High quality strain relief and sealing, reliable performance for standard industrial applications.
- Up-to-date international approvals.

Technical Details	
Material	PA 6 (Polyamide 6) (R22, HL3 and R23, HL3)
Body, Cap Seal	EPDM (R22, HL3 and R23, HL3)
Ingress Protection Rating	IP 68 - 5 Bar, 30 min IP 66
Flammability	R22 acc. to EN45545-2 R23 acc. to EN45545-2 HL2 acc. to EN45545-2 HL3 acc. to EN45545-2
Operating Temperature	EPDM -40 °C to +100 °C
Thread Type	<ul style="list-style-type: none"> • Metric EN 60423 • PG DIN 40430 • NPT ANSI B1.20.1 • Gas ISO 228 • Other thread types also available upon request.
Cable Type	Non armoured
Accessories	<ul style="list-style-type: none"> • Lock nuts • Dome plugs • Reducing seals • Flat cable seals • Multihole seals • Gaskets (Washers)
Remarks	<ul style="list-style-type: none"> • Manufactured according to DIN EN 62444/50262. • We recommend the use of locknuts and gaskets to ensure IP rating for rough surfaces or through holes. • Some approvals do not cover all sizes. • Accessories must be ordered separately. • Other colours on request: RAL 5015 (blue) RAL 9003 (white) RAL 3020 (red)

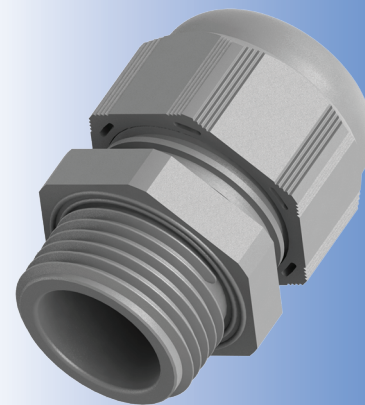

Order Coding				
Part Number	-	Gasket (Washer)	Sealing Plug	Lock Nut
Mandatory	-	Option	Option	Option
See table	-	WC Chloroprene WS Silicone	P Dome Plug	L Lock nut
Example				
R-BM-12L	-	WC	P	L

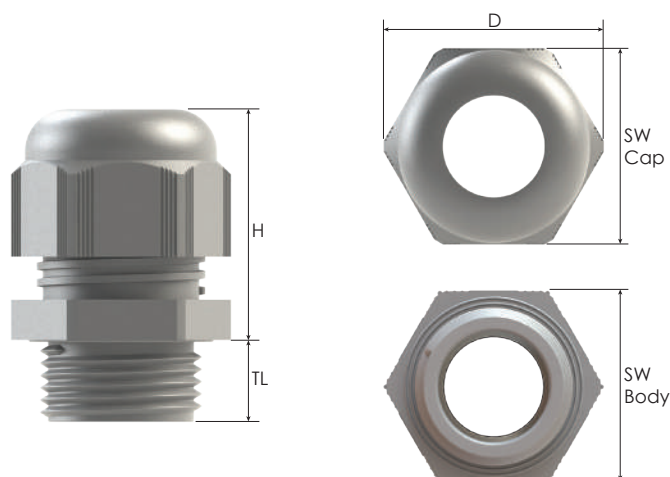

Cable Glands for Railway Applications, Polyamide

Thread Type METRIC acc. to EN 60423												
Outer Thread Size (Male)	Clamping Range Ø min - max mm	Outer Thread Length TL mm	Spanner Width Cap		Spanner Width Body		Outer Ø D mm	max. Height H mm	Part Number			Minimum Order Quantity
			SW Cap mm	SW Body mm	RAL 7035 light grey	RAL 7001 grey			RAL 9005 black			
M12x1,5	3,0 - 6,5	8,0	15	15	17,0	25,3	R-BM-1S	R-BM-0S	R-BM-2S	4000		
M16x1,5	4,0 - 8,0	8,0	19	19	21,7	27,4	R-BM-EN-11	R-BM-EN-01	R-BM-EN-21	2000		
	4,0 - 8,0	10,0	19	19	21,7	27,4	R-BM-EN-11M	R-BM-EN-01M	R-BM-EN-21M	2000		
	5,0 - 10,0	10,0	22	22	25,0	32,2	R-BM-11	R-BM-01	R-BM-21	1800		
M20x1,5	5,0 - 10,0	15,0	22	22	25,0	32,2	R-BM-11L	R-BM-01L	R-BM-21L	1500		
	6,0 - 12,0	10,0	24	24	27,0	32,4	R-BM-12	R-BM-02	R-BM-22	1600		
	6,0 - 12,0	15,0	24	24	27,0	32,4	R-BM-12L	R-BM-02L	R-BM-22L	1000		
	10,0 - 14,0	10,0	27	27	30,9	31,9	R-BM-13	R-BM-03	R-BM-23	1000		
	10,0 - 14,0	15,0	27	27	30,9	31,9	R-BM-14	R-BM-04	R-BM-24	850		
M25x1,5	13,0 - 18,0	10,0	33	33	37,2	38,4	R-BM-15	R-BM-05	R-BM-25	600		
	13,0 - 18,0	15,0	33	33	37,2	38,4	R-BM-16	R-BM-06	R-BM-26	600		
M32x1,5	18,0 - 25,0	15,0	42	42	47,1	43,3	R-BM-17	R-BM-07	R-BM-27	400		
M40x1,5	22,0 - 32,0	18,0	53	53	59,6	52,4	R-BM-18	R-BM-08	R-BM-28	200		

Polyamide PRESSURE BALANCE ELEMENTS for Industrial Applications

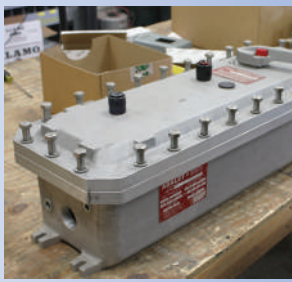

Ventilation Glands
Ventilation Plugs
Drain Plugs

70 - 71
72 - 73
74 - 75

Metal PRESSURE BALANCE ELEMENTS for Industrial Applications



Ventilation Glands
Ventilation Plugs
Drain Plugs
Further Accessories
Applications

76 - 77
78 - 79
80 - 81
82
83





Ventilation Glands Polyamide

Cable glands with integrated ventilation

- Balances pressure differences between inner housing and the outside environment.
- Prevents damages according to pressure differences.
- Prevents the formation of water condensation in tightly-sealed standard housings.
- Advantages of cable gland and pressure balance element combined in one product.
- Properties of the ventilation membrane stay the same independent of cable diameter and torque.
- Membrane properties: hydrophobic, oleophobic.
- Easy assembly: install cable gland - insert cable - tighten cap.
- High quality strain relief and sealing reliable performance for standard industrial applications.
- Up-to-date international approvals.

Technical Details

Body, Cap	PA 6 (Polyamide 6)	
Seal	CR (Chloroprene)	
Material		
Vent. Membran	PTFE	
Gasket	NBR	
Ingress Protection Rating	IP 66 IP 67	
Flammability	V2 according to UL94	
Operating Temperature	Permanent	Intermittent
	-20 °C to +100 °C	-30 °C to +150 °C
Cable Type	Non armoured	
Thread Type	<ul style="list-style-type: none"> • Metric EN 60423 • PG DIN 40430 • Other thread types also available upon request. 	
Accessories	<ul style="list-style-type: none"> • Lock nuts • Dome plugs 	
Remarks	<ul style="list-style-type: none"> • Manufactured according to DIN EN 62444/50262. • We recommend the use of lock nuts and gaskets to ensure IP rating for rough surfaces or through holes. • Accessories must be ordered separately. • Some approvals do not cover all colours or sizes. 	

Approvals	Certificate Number	Standards
	134171	DIN EN 62444
	115116_0_000	CSA C22.2
	E199260	UL514B CSA22.2 No 18.3-12 CSA22.2 No 94.2-15
TYPE 4X		UL50E
	E-14046	EN62444

For more approvals: see our webpage.

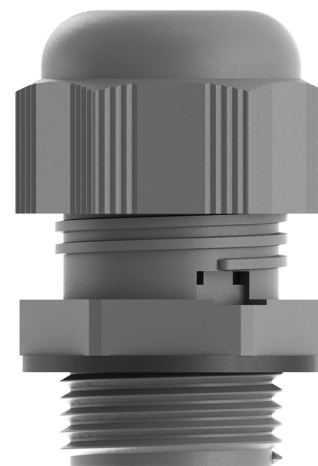

Ventilation Glands Polyamide

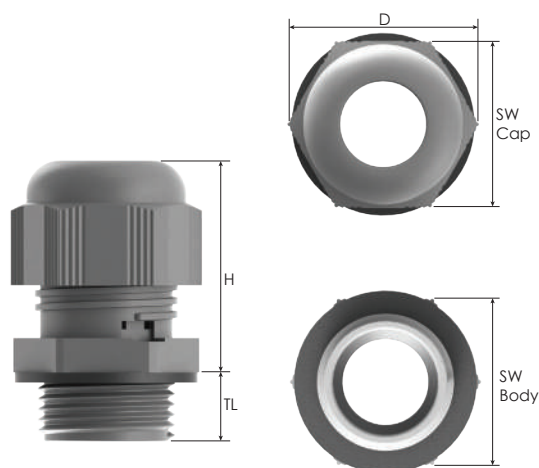

Thread Type METRIC acc. to EN 60423

Outer Thread Size (Male)	Clamping Range Ø min-max mm	Average Air Flow for $\Delta P = 70$ mbar/1 psi l/h	Water Intrusion bar	Outer Thread Length TL mm	Spanner Width		Outer Ø D mm	max. Height H mm	Part Number			Minimum Order Quantity
					SW Cap mm	SW Body mm			RAL 7035 light grey	RAL 7001 grey	RAL 9005 black	
M12x1,5	4,0 - 7,0	25	0,1	8,0	19	19	21,7	28,3	BMVG-1S	BMVG-0S	BMVG-2S	2000
M16x1,5	4,0 - 7,0	25	0,1	10,0	19	19	21,7	28,3	BMVG-11	BMVG-01	BMVG-21	2000
M20x1,5	6,0 - 11,0	40	0,1	10,0	24	24	27,0	33,3	BMVG-12	BMVG-02	BMVG-22	1500

Thread Type PG acc. to DIN 40430

Outer Thread Size (Male)	Clamping Range Ø min-max mm	Average Air Flow for $\Delta P = 70$ mbar/1 psi l/h	Water Intrusion bar	Outer Thread Length TL mm	Spanner Width		Outer Ø D mm	max. Height H mm	Part Number			Minimum Order Quantity
					SW Cap mm	SW Body mm			RAL 7035 light grey	RAL 7001 grey	RAL 9005 black	
PG 9	4,0 - 7,0	25	0,1	8,0	19	19	21,7	28,3	BSVG-12	BSVG-02	BSVG-22	2000
PG 11	4,0 - 7,0	25	0,1	8,0	19	22	24,9	28,3	BSVG-13	BSVG-03	BSVG-23	1500
PG 13,5	6,0 - 11,0	40	0,1	9,0	24	24	27,0	33,3	BSVG-14	BSVG-04	BSVG-24	1500

Ventilation Plugs Polyamide

Ventilation plugs

- Balances pressure differences between inner housing and the outside environment.
- Prevents damages according to pressure differences.
- Prevents the formation of water condensation in tightly-sealed standard housings.
- Membrane properties: hydrophobic, oleophobic.

Technical Details

Body	PA 6 (Polyamide 6)	
Vent Membran	Acrylic co-polymer on nylon-support	
O-Ring	NBR	
Gaskets	NBR (standard for B and J types)	
Ingress Protection Rating	IP 68 / IP 67 (for water intrusion pressure 0.1 bar) IP 69K (only for J and D types)	
Flammability	V2 according to UL94	
Operating Temperature	Permanent	-20 °C to +100 °C
	Intermittent	-30 °C to +150 °C
Thread Type	<ul style="list-style-type: none"> • Metric EN 60423 • without thread 	
Accessories	<ul style="list-style-type: none"> • Lock nuts • Gaskets 	
Remarks	<ul style="list-style-type: none"> • We recommend the use of lock nuts and gaskets to ensure IP rating for rough surfaces or through holes. • Some approvals do not cover all colours or sizes. 	

Approvals	Certificate Number	Standards
 TYPE 4X	E350312	CAN/CSA C22.2 No.14-2010

For more approvals: see our webpage.

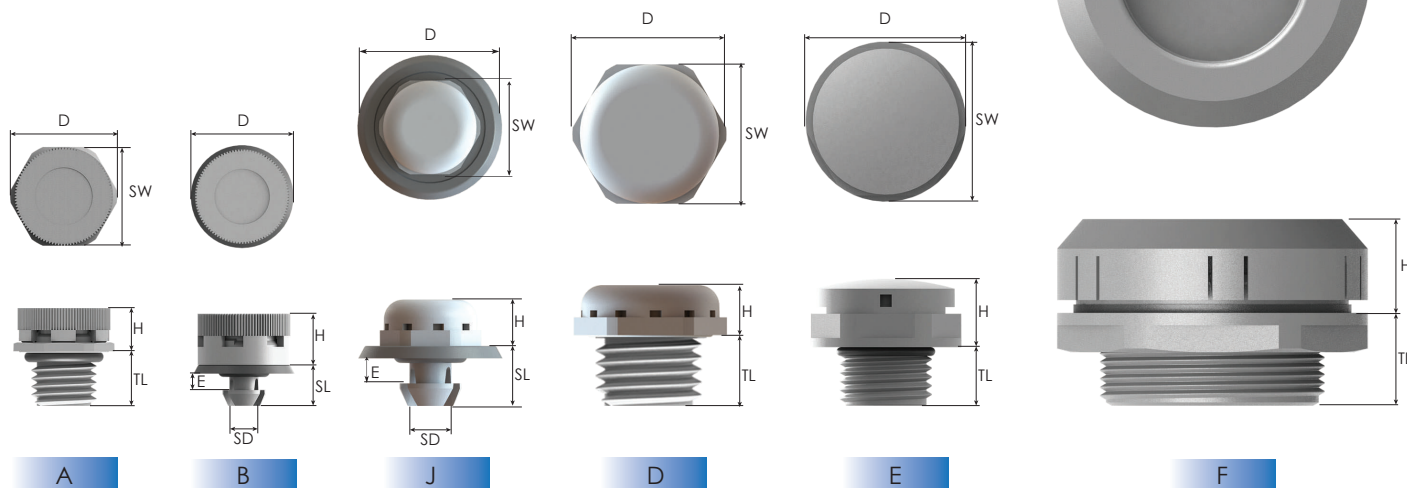

Ventilation Plugs Polyamide

Thread Type METRIC acc. to EN 60423

Outer Thread Size (Male)	Average Air Flow for $\Delta P = 70 \text{ mbar}/1 \text{ psi}$	Water Intrusion Pressure	Outer Thread Length		Spanner Width		Outer \varnothing		Height	Design Type	Part Number			Minimum Order Quantity
			TL mm	SW mm	D mm	H mm	RAL 7035 light grey	RAL 7001 grey			RAL 9005 black			
M6x0,75	8	0,5	10,0	10	11,0	6,15	D	MBVPG-11	MBVPG-01	MBVPG-21	5000			
M8x1,0	15	0,5	10,0	12	13,0	6,15	D	MBVPG-12	MBVPG-02	MBVPG-22	5000			
M12x1,0	16	0,9	6,6	17	18,5	7,6	A	SBVPA-11	SBVPA-01	SBVPA-21	5000			
	25	0,5	6,6	17	18,5	7,6	A	MBVPA-11	MBVPA-01	MBVPA-21	5000			
	120	0,2	6,6	17	18,5	7,6	A	HBVPA-11	HBVPA-01	HBVPA-21	5000			
	300	0,1	6,6	17	18,5	7,6	A	UHBVPA-11	UHBVPA-01	UHBVPA-21	5000			
M12x1,5	25	0,5	10,0	17	18,8	6,15	D	MBVPG-13	MBVPG-03	MBVPG-23	5000			
	16	0,9	6,0	17	18,5	7,6	A	SBVPB-11	SBVPB-01	SBVPB-21	5000			
	16	0,9	10,0	17	18,5	7,6	A	SBVPB-11L	SBVPB-01L	SBVPB-21L	5000			
	25	0,5	6,0	17	18,5	7,6	A	MBVPB-11	MBVPB-01	MBVPB-21	5000			
	25	0,5	10,0	17	18,5	7,6	A	MBVPB-11L	MBVPB-01L	MBVPB-21L	5000			
	42	0,9	10,0	24	26,0	11,7	E	SBVPD-11	SBVPD-01	SBVPD-21	5000			
	120	0,5	10,0	24	26,0	11,7	E	MBVPD-11	MBVPD-01	MBVPD-21	5000			
	120	0,2	6,0	17	18,5	7,6	A	HBVPB-11	HBVPB-01	HBVPB-21	5000			
	120	0,2	10,0	17	18,5	7,6	A	HBVPB-11L	HBVPB-01L	HBVPB-21L	5000			
	300	0,1	6,0	17	18,5	7,6	A	UHBVPB-11	UHBVPB-01	UHBVPB-21	5000			
	300	0,1	10,0	17	18,5	7,6	A	UHBVPB-11L	UHBVPB-01L	UHBVPB-21L	5000			
	450	0,2	10,0	24	26,0	11,7	E	HBVPD-11	HBVPD-01	HBVPD-21	5000			
	750	0,1	10,0	24	26,0	11,7	E	UHBVPD-11	UHBVPD-01	UHBVPD-21	5000			
	M16x1,5	42	0,9	10,0	24	26,0	11,7	E	SBVPF-11	SBVPF-01	SBVPF-21	5000		
		120	0,5	10,0	24	26,0	11,7	E	MBVPF-11	MBVPF-01	MBVPF-21	5000		
		450	0,2	10,0	24	26,0	11,7	E	HBVPF-11	HBVPF-01	HBVPF-21	5000		
750		0,1	10,0	24	26,0	11,7	E	UHBVPF-11	UHBVPF-01	UHBVPF-21	5000			
M20x1,5	42	0,9	10,0	24	26,0	11,7	E	SBVPE-11	SBVPE-01	SBVPE-21	5000			
	120	0,5	10,0	24	26,0	11,7	E	MBVPE-11	MBVPE-01	MBVPE-21	5000			
	450	0,2	10,0	24	26,0	11,7	E	HBVPE-11	HBVPE-01	HBVPE-21	5000			
	750	0,1	10,0	24	26,0	11,7	E	UHBVPE-11	UHBVPE-01	UHBVPE-21	5000			
M40x1,5	120	0,9	18,0	-	55,3	15,5	F	SBVPX-18S	SBVPX-08S	SBVPX-28S	400			
	375	0,5	18,0	-	55,3	15,5	F	MBVPX-18S	MBVPX-08S	MBVPX-28S	400			
	1350	0,2	18,0	-	55,3	15,5	F	HBVPX-18S	HBVPX-08S	HBVPX-28S	400			
	2200	0,1	18,0	-	55,3	15,5	F	UHBVPX-18S	UHBVPX-08S	UHBVPX-28S	400			

wall thickness (E) : 2,5 mm

Snap Size	Average Air Flow for $\Delta P = 70 \text{ mbar}/1 \text{ psi}$	Water Intrusion Pressure	Snap		Outer \varnothing	Spanner Width	Height	Design Type	Part Number			Minimum Order Quantity
			Length	\varnothing					D mm	SW mm	H mm	
Snapfit 5,5	16	0,9	7,5	5,4	18,5	-	9,3	B	SBVQ-M11	SBVQ-M01	SBVQ-M21	500
	25	0,5	7,5	5,4	18,5	-	9,3	B	MBVQ-M11	MBVQ-M01	MBVQ-M21	500
	120	0,2	7,5	5,4	18,5	-	9,3	B	HBVQ-M11	HBVQ-M01	HBVQ-M21	500
	300	0,1	7,5	5,4	18,5	-	9,3	B	UHBVQ-M11	UHBVQ-M01	UHBVQ-M21	500

wall thickness (E) : 3,2 mm

Snapfit 5,5	15	0,5	7,5	5,4	18,5	12	6,15	J	MBVPGQ-12	MBVPGQ-02	MBVPGQ-22	500
	25	0,5	7,5	5,4	18,5	17	6,15	J	MBVPGQ-13	MBVPGQ-03	MBVPGQ-23	500

Drain Plugs Polyamide

Drain Plugs

- Balances pressure differences between inner housing and the outside environment.
- Prevents damages according to pressure differences.
- Prevents the formation of water condensation in tightly-sealed standard housings.
- Membrane properties: hydrophobic, oleophobic.

Technical Details

Material	Body	PA 66	
Ingress Protection Rating	IP 56 / IP 66 (Category 2)		
Flammability	V2 according to UL94		
Operating Temperature	Permanent	-20 °C to +100 °C	
	Intermittent	-30 °C to +150 °C	
Thread Type	• Metric EN 60423		
Accessories	• Lock nuts		
	• Gaskets (Washers)		
Remarks	• We recommend the use of lock nuts and gaskets to ensure IP rating for rough surfaces or through holes.		
	• Accessories must be ordered separately.		



Order Coding			
Part Number	-	Lock Nut	
Mandatory	-	Option	
See table	-	L	Lock nut
Example			
BPDRP-11	-	L	



With special lock nut

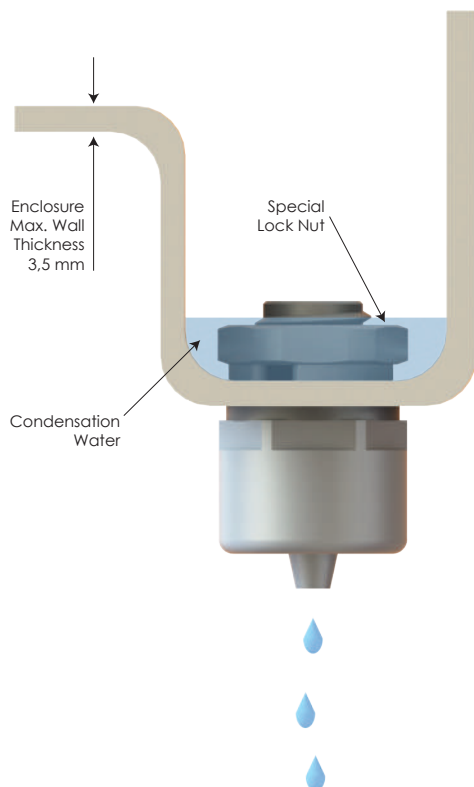

Without special lock nut

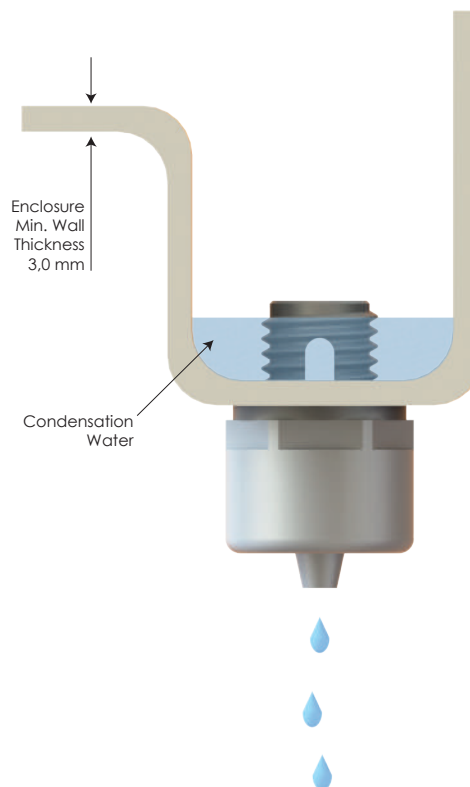

Drain Plugs Polyamide

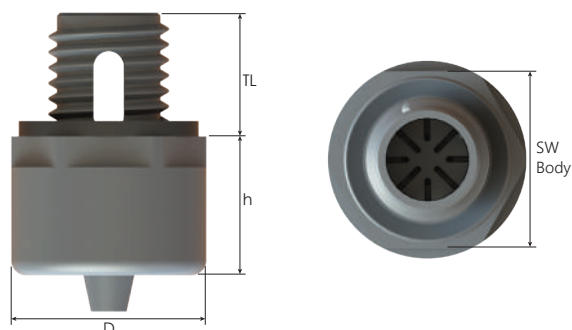

Thread Type **METRIC** acc. to EN 60423

Outer Thread Size (Male)	Outer Thread Length TL mm	Outer Ø D mm	Height h mm	Part Number			Minimum Order Quantity
				RAL 7035 light grey	RAL 7001 grey	RAL 9005 black	
M12x1,5	12,0	19,0	17,0	BPDRP-11	BPDRP-01	BPDRP-21	500

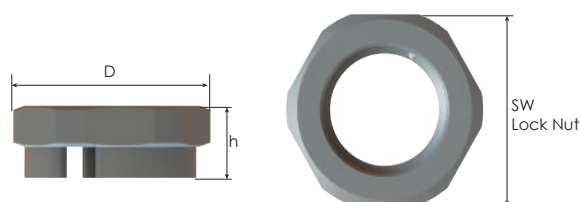
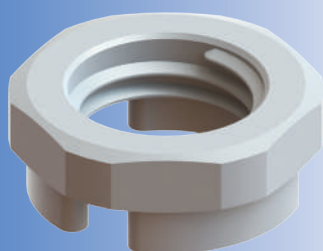

Special Lock Nuts for Drain Plugs

Inner Thread Size (Female)	Spanner Width SW Lock Nut mm	Outer Ø D mm	Height h mm	Part Number			Minimum Order Quantity
				RAL 7035 light grey	RAL 7001 grey	RAL 9005 black	
M12x1,5	18	19,2	7,0	BMDL-1S	BMDL-0S	BMDL-2S	500



Ventilation Cable Glands Brass

Cable glands with integrated ventilation

- Balances pressure differences between inside and outside of enclosure.
- Prevents damages, such as condensation due to pressure differences.
- Cable gland and pressure balance element combined in one product.
- Properties of ventilation membrane stay the same independent of cable diameter and torque.
- Membrane properties: hydrophobic, oleophobic.
- For industrial applications in harsh environments.
- Easy assembly.
- High quality strain relief and sealing, reliable performance for standard industrial applications.
- Up-to-date international approvals.

Technical Details

Material	Body, Cap	Brass Nickel plated	
	Seal	CR (Chloroprene)	
	Clamp, Insert	PA 6 (Polyamide 6)	
	Vent Membran	PTFE	
	O-Ring	NBR	
Ingress Protection Rating	IP 66	IP 67	
Flammability	V2 according to UL94		
Operating Temperature	Permanent	Intermittent	
	-20 °C to +100 °C	-40 °C to +150 °C	
Cable Type	Non armoured		
Thread Type	• Metric EN 60423		
	• PG DIN 40430		
	• Other thread types also available upon request.		
	• Lock nuts		
Accessories	• Dome plugs		
	• Gaskets		
	• Manufactured according to DIN EN 62444/50262.		
Remarks	• We recommend the use of lock nuts and gaskets to ensure IP rating for rough surfaces or through holes.		
	• O-ring available in Metric and PG threads.		
	• Accessories must be ordered separately.		
	• Some approvals do not cover all sizes.		
	Note: Applications of most cable glands don't require same parameters applied to tests. For applications strictly acc. to the approval definitions please consult data sheet.		

Approvals	Certificate Number	Standards
	40040032	DIN EN 62444
	E-199260	UL514B CSA22.2 No 18.3-12 CSA22.2 No 94.2-15
TYPE 4x		UL50E
	E-14047	EN62444

For more approvals: see our webpage.

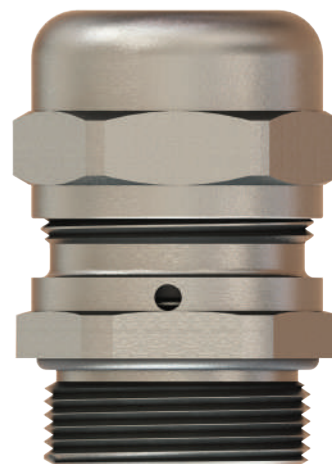

Ventilation Cable Glands Brass

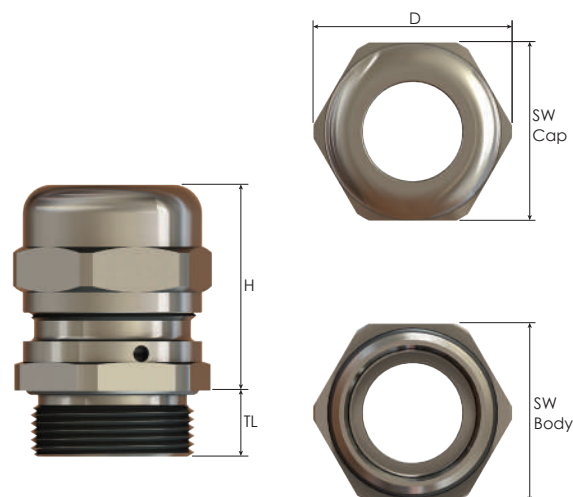

Thread Type **METRIC** acc. to EN 60423

Outer Thread Size (Male)	Clamping Range Ø min-max mm	Average Air Flow for ΔP = 70 mbar l/h	Water Intrusion Pressure bar	Outer Thread Length TL mm	Spanner Width		Outer Ø D mm	max. Height H mm	Part Number	Minimum Order Quantity
					SW Cap mm	SW Body mm				
M12x1,5	2,0 - 6,0	25	0,1	8,0	17	17	18,9	32,5	BMBCVG-0SR	1000
	4,0 - 7,0	25	0,1	8,0	17	17	18,9	32,5	BMBCVG-0S	1000
M16x1,5	2,0 - 6,0	25	0,1	8,0	17	17	18,9	29,0	BMBCVG-01R	900
	4,0 - 7,0	25	0,1	8,0	17	17	18,9	29,0	BMBCVG-01	900
	3,0 - 7,0	35	0,1	8,0	20	20	22,0	36,0	BMBCVG-01LR	600
	5,0 - 9,0	35	0,1	8,0	20	20	22,0	36,0	BMBCVG-01L	600
M20x1,5	5,0 - 9,0	50	0,1	8,0	22	22	24,5	32,5	BMBCVG-02R	500
	6,0 - 11,0	50	0,1	8,0	22	22	24,5	32,5	BMBCVG-02	500

Thread Type **PG** acc. to DIN 40430

Outer Thread Size (Male)	Clamping Range Ø min-max mm	Average Air Flow for ΔP = 70 mbar l/h	Water Intrusion Pressure bar	Outer Thread Length TL mm	Spanner Width		Outer Ø D mm	max. Height H mm	Part Number	Minimum Order Quantity
					SW Cap mm	SW Body mm				
PG 7	2,0 - 6,0	25	0,1	8,0	17	17	18,9	32,5	BSBCVG-01R	1000
	4,0 - 7,0	25	0,1	8,0	17	17	18,9	32,5	BSBCVG-01	1000
PG 9	2,0 - 6,0	25	0,1	8,0	17	17	18,9	29,0	BSBCVG-02R	900
	4,0 - 7,0	25	0,1	8,0	17	17	18,9	29,0	BSBCVG-02	900
PG 11	3,0 - 7,0	35	0,1	8,0	20	20	22,0	36,0	BSBCVG-03R	600
	5,0 - 9,0	35	0,1	8,0	20	20	22,0	36,0	BSBCVG-03	600
PG 13,5	5,0 - 9,0	50	0,1	9,0	22	22	24,5	32,5	BSBCVG-04R	500
	6,0 - 11,0	50	0,1	9,0	22	22	24,5	32,5	BSBCVG-04	500

Ventilation Plugs Metal

Ventilation plugs for pressure balancing

- Balances pressure differences between inside and outside of enclosure.
- Prevents damages, such as condensation due to pressure differences.
- Membrane properties: hydrophobic, oleophobic.
- For industrial applications in harsh environments.

Technical Details

Material	Vent. Plug	Stainless steel, Aluminium	
	Vent. Membran	Acrylic copolymer on nylon-support	
	O-Ring	NBR	
Ingress Protection Rating	IP 68 / IP 67 (for water intrusion pressure 0.1 bar)		
Operating Temperature	Permanent	-20 °C to +100 °C	
	Intermittent	-30 °C to +150 °C	
Thread Type	<ul style="list-style-type: none"> • Metric EN 60423 • PG DIN 40430 • Other thread types also available upon request. 		
Accessories	<ul style="list-style-type: none"> • Lock nuts • Gaskets (Washers) 		
Remarks	<ul style="list-style-type: none"> • We recommend the use of lock nuts and gaskets to ensure IP rating for rough surfaces or through holes. • O-ring available all products except D-type M40. • Accessories must be ordered separately. • Some approvals do not cover all sizes. 		
Approvals	Certificate Number	Standards	
 TYPE 4x	E350312	UL514B CSA22.2 No 18.3-12 CSA22.2 No 94.2-1S	
		UL50E	

For more approvals: see our webpage.

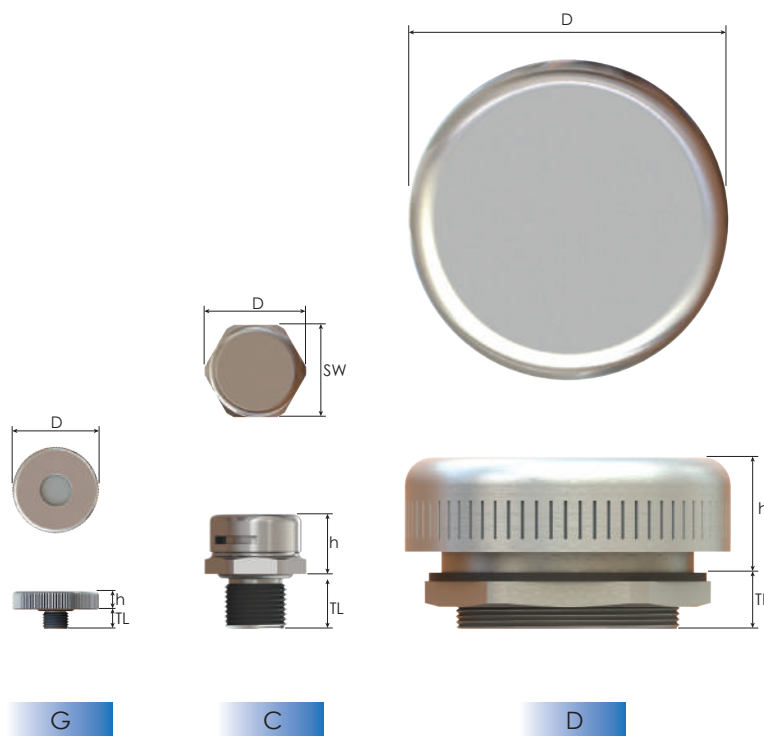

Ventilation Plugs Metal

Thread Type **METRIC** acc. to EN 60423 (Stainless Steel)

Size	Average Air Flow for $\Delta P = 70$ mbar	Water Intrusion Pressure	Outer Thread Length	Spanner Width	Outer \varnothing	Height	Design Type	Part Number	Minimum Order Quantity
	l/h	bar	TL mm	SW mm	D mm	h mm			
M12x1,0	16	0,9	10,0	17	18,8	11,0	C	SBBVP-01S	1000
	25	0,5	10,0	17	18,8	11,0	C	MBBVP-01S	1000
	120	0,2	10,0	17	18,8	11,0	C	HBBVP-01S	1000
	300	0,1	10,0	17	18,8	11,0	C	UHBBVP-01S	1000
M12x1,5	16	0,9	6,0	17	18,8	11,0	C	SBBVP-01	1000
	16	0,9	10,0	17	18,8	11,0	C	SBBVP-01L	1000
	25	0,5	6,0	17	18,8	11,0	C	MBBVP-01	1000
	25	0,5	10,0	17	18,8	11,0	C	MBBVP-01L	1000
	120	0,2	6,0	17	18,8	11,0	C	HBBVP-01	1000
	120	0,2	10,0	17	18,8	11,0	C	HBBVP-01L	1000
	300	0,1	6,0	17	18,8	11,0	C	UHBBVP-01	1000
	300	0,1	10,0	17	18,8	11,0	C	UHBBVP-01L	1000
M16x1,5	16	0,9	6,0	18	20,0	12,0	C	SBBVP-02	900
	16	0,9	6,0	18	20,0	16,0	C	SBBVP-02L	900
	25	0,5	6,0	18	20,0	12,0	C	MBBVP-02	900
	25	0,5	6,0	18	20,0	16,0	C	MBBVP-02L	900
	120	0,2	6,0	18	20,0	12,0	C	HBBVP-02	900
	120	0,2	6,0	18	20,0	16,0	C	HBBVP-02L	900
	300	0,1	6,0	18	20,0	12,0	C	UHBBVP-02	900
	300	0,1	6,0	18	20,0	16,0	C	UHBBVP-02L	900
M20x1,5	16	0,9	6,0	22	24,5	13,0	C	SBBVP-03	500
	16	0,9	6,0	22	24,5	17,0	C	SBBVP-03L	500
	25	0,5	6,0	22	24,5	13,0	C	MBBVP-03	500
	25	0,5	6,0	22	24,5	17,0	C	MBBVP-03L	500
	120	0,2	6,0	22	24,5	13,0	C	HBBVP-03	500
	120	0,2	6,0	22	24,5	17,0	C	HBBVP-03L	500
	300	0,1	6,0	22	24,5	13,0	C	UHBBVP-03	500
	300	0,1	6,0	22	24,5	17,0	C	UHBBVP-03L	500
M40x1,5	120	0,9	10,0	-	58,0	20,5	D	SBBVPX-05	100
	375	0,5	10,0	-	58,0	20,5	D	MBBVPX-05	100
	1350	0,2	10,0	-	58,0	20,5	D	HBBVPX-05	100
	2200	0,1	10,0	-	58,0	20,5	D	UHBBVPX-05	100

Thread Type **METRIC** acc. to EN 60423 (Aluminium)

Size	Average Air Flow for $\Delta P = 70$ mbar	Water Intrusion Pressure	Outer Thread Length	Spanner Width	Outer \varnothing	Height	Design Type	Part Number	Minimum Order Quantity
	l/h	bar	TL mm	SW mm	D mm	h mm			
M4x0,7	4	0,9	3	-	12,3	2,7	G	SBAVP-01	1000
	7	0,5	3	-	12,3	2,7	G	MBAVP-01	1000
	35	0,2	3	-	12,3	2,7	G	HBAVP-01	1000
	100	0,1	3	-	12,3	2,7	G	UHBAVP-01	1000
M8x0,75	4	0,9	8	-	12,3	2,7	G	SBAVP-02	1000
	7	0,5	8	-	12,3	2,7	G	MBAVP-02	1000
	35	0,2	8	-	12,3	2,7	G	HBAVP-02	1000
	100	0,1	8	-	12,3	2,7	G	UHBAVP-02	1000

Thread Type **PG** acc. to DIN 40430 (Stainless Steel)

Size	Average Air Flow for $\Delta P = 70$ mbar	Water Intrusion Pressure	Outer Thread Length	Spanner Width	Outer \varnothing	Height	Design Type	Part Number	Minimum Order Quantity
	l/h	bar	TL mm	SW mm	D mm	h mm			
PG 7	16	0,9	10,5	17	18,8	11,0	C	SBBVP-0S	1000
	25	0,5	10,5	17	18,8	11,0	C	MBBVP-0S	1000
	120	0,2	10,5	17	18,8	11,0	C	HBBVP-0S	1000
	300	0,1	10,5	17	18,8	11,0	C	UHBBVP-0S	1000
PG 9	16	0,9	6,0	19	21,0	12,0	C	SBBVPP-02	1000
	25	0,5	6,0	19	21,0	12,0	C	MBBVPP-02	1000
	120	0,2	6,0	19	21,0	12,0	C	HBBVPP-02	1000
	300	0,1	6,0	19	21,0	12,0	C	UHBBVPP-02	1000

Drain Plugs, Metal

Drain Plugs

- Balances pressure differences between inner housing and the outside environment.
- Prevents damages according to pressure differences.
- Prevents the formation of water condensation in tightly-sealed standard housings.
- Membrane properties: hydrophobic, oleophobic.

Technical Details

Material	Body	Brass, Brass Nickel Plated, Stainless Steel
	Bushing	Bronze
	O-ring	Silicone
Ingress Protection Rating		IP 68 - 5 Bar, 30 min
		IP 66
Operating Temperature	Seal Material	Silicone
		-60°C to +85°C
Thread Type		Metric (M) EN 60423 NPT (N) ANSI ASME B1.20.1
Accessories		• Lock nuts • Gaskets (Washers)
		• We recommend the use of lock nuts and gaskets to ensure IP rating for rough surfaces or through holes. • Accessories must be ordered separately. • O-ring available in Metric threads.
Remarks		

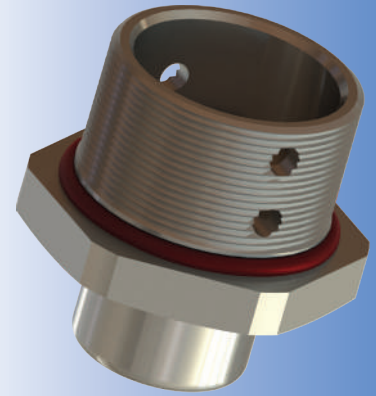

Threaded Hole

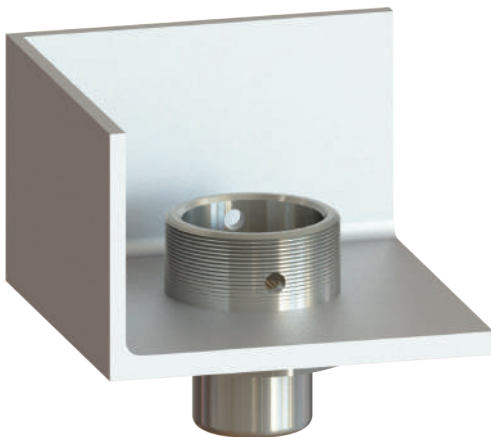

Non-Threaded Hole

Special Lock Nut for Drain Plug

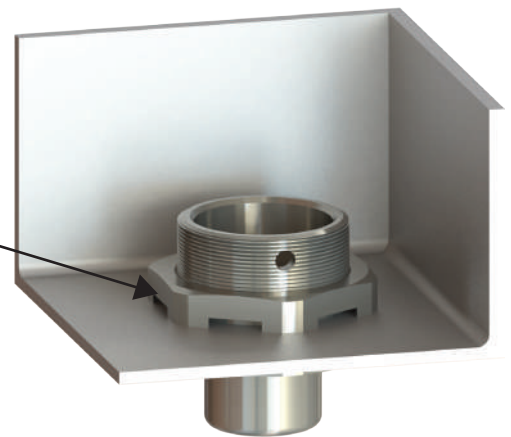

Order Coding				
Part Number	Material	Seal	-	Lock Nut
Mandatory	Mandatory	Mandatory	-	Option
See table	B Brass BN Brass Nickel Plated X Stainless Steel	S Silicone	-	L Lock Nut
Example				
IBDRV-1M	BN	S	-	L

Drain Plugs, Metal

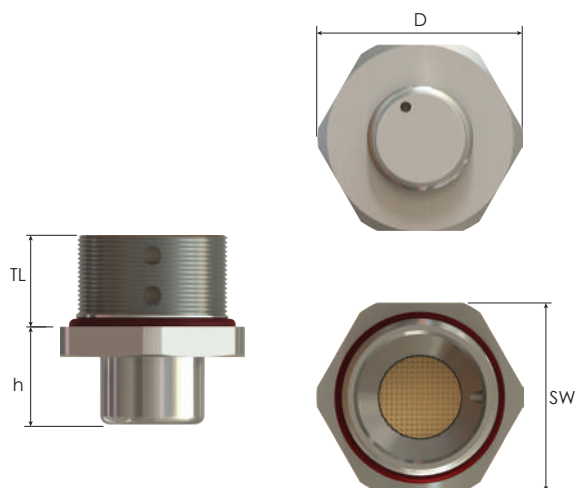

Thread Type **METRIC** acc. to EN 60423

Outer Thread Size (Male)	Outer Thread Length TL mm	Spanner Width SW mm	Outer Ø D mm	Height h mm	Part Number	Minimum Order Quantity
M20x1,5	15,0	25	27,5	16,0	IBDRV-1M	189
M25x1,5	15,0	30	33,0	16,0	IBDRV-2M	105

Thread Type **NPT** acc. to ANSI ASME B1.20.1



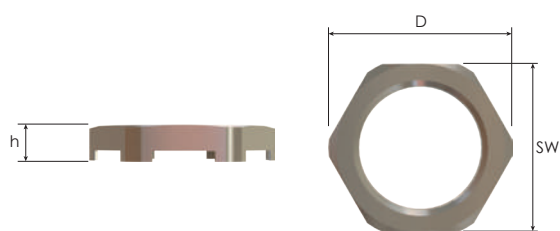
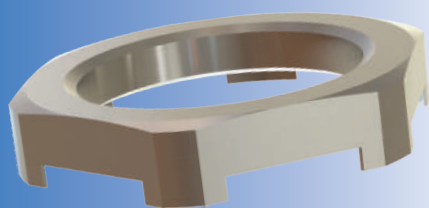

Outer Thread Size (Male)	Outer Thread Length TL mm	Spanner Width SW mm	Outer Ø D mm	Height h mm	Part Number	Minimum Order Quantity
NPT 1/2"	16,0	25	27,5	16,0	IBDRV-1N	189
NPT 3/4"	16,0	30	33,0	16,0	IBDRV-2N	105



Special Lock Nuts for Drain Plugs

Inner Thread Size (Female)	Spanner Width SW mm	Outer Ø D2 mm	Height h mm	Part Number	Minimum Order Quantity
M20x1,5	25	27,5	5,0	BDRL-03	189
M25x1,5	30	33,0	5,0	BDRL-04	105
NPSL 1/2"	25	27,5	5,0	BDRLN-03	189
NPSL 3/4"	30	33,0	5,0	BDRLN-04	105

Further Accessories for Ventilation Glands & Plugs

Dome Plugs	Dome Plugs		283 - 284
Lock Nuts	Plastic Lock Nuts		291 - 292
	Metal Lock Nuts		293 - 295
Gaskets	Gaskets		287 - 288

Pressure Balance Elements Applications

Car Head Lamps



Led Lighting & Wall Washer Lighting



Control Cabinets



Power Supply



Outdoor Lighting



Solar Panels



Stainless Steel HYGIENIC GLANDS for Industrial Applications

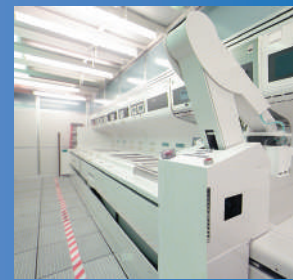

Hygienic Glands
Hygienic Glands, EMC

86 - 87
88 - 89

Stainless Steel Liquidtight HYGIENIC CONDUIT FITTINGS for Industrial Applications



Hygienic Fittings
Further Accessories
Applications

90 - 91
92
93



Hygienic Cable Glands Stainless Steel

Cable glands for hygienic requirements

- For applications in manufacturing and packaging of food and pharmaceuticals, clean room technology, biotechnology, chemical industry.
- Smooth finish prevents harmful micro organisms to stick to the surface.
- No threads are exposed.
- Gasket material according to FDA guideline 21 CFR 177.2600.
- Cleaning of cable glands is easier, faster and less expensive.
- Reliable strain relief due to strain relief element separated from grommet.
- Suitable for high pressure steam cleaning.
- Lock nut included.

Technical Details

Material	Body, Cap	Stainless steel 1.4305 (AISI 303)	
	Clamp, Insert	POM	
	Seal	TPE	
Ingress Protection Rating		IP 68 - 5 Bar, 30 min IP 69	
Operating Temperature	Permanent	-20 °C to +100 °C	
	Intermittent	-40 °C to +150 °C	
Cable Type		Non armoured	
Thread Type		<ul style="list-style-type: none"> • Metric EN 60423 • Other thread types also available upon request. 	
Accessories		<ul style="list-style-type: none"> • Lock nuts • Dome plugs • Assembling tools 	
Remarks		<ul style="list-style-type: none"> • Manufactured according to DIN EN 62444/50262. • We recommend the use of lock nuts to ensure IP rating for rough surfaces or through holes. • Accessories must be ordered separately. • Some approvals do not cover all sizes. 	
		<p>Note: Applications of most cable glands don't require same parameters applied to tests. For applications strictly acc. to the approval definitions please consult data sheet.</p>	

Approvals	Certificate Number	Standards
	4001820	DIN EN 62444
	485TUM2016 No.15/2015	EHEDG-Doc. 2, 3rd edition, 2004,
	E-14047	EN62444

For more approvals: see our webpage.

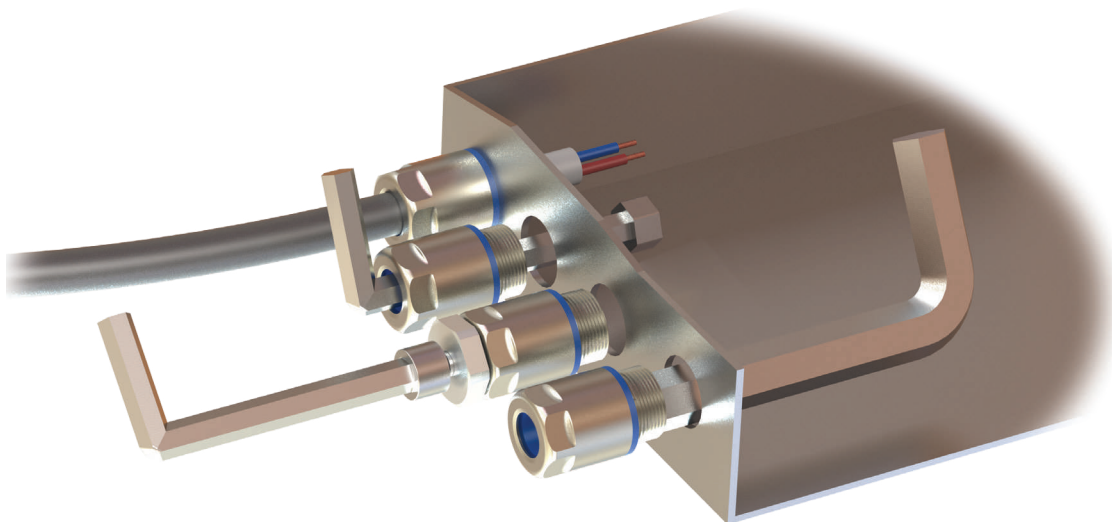
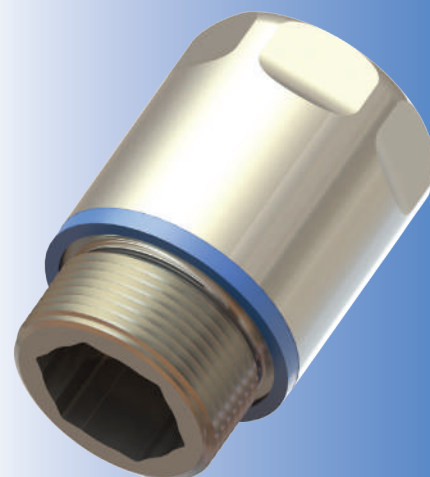

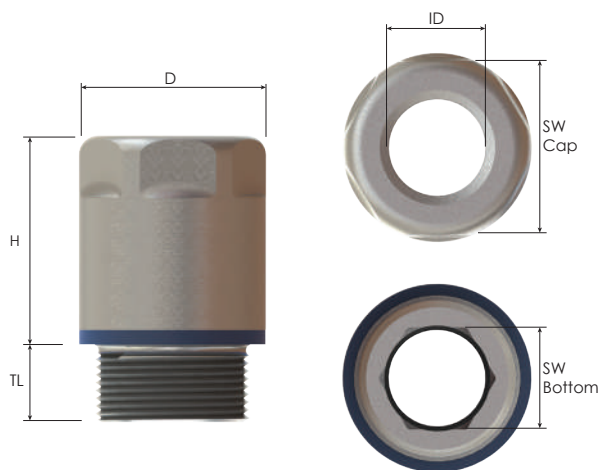

Hygienic Cable Glands Stainless Steel

Thread Type **METRIC** acc. to EN 60423

Outer Thread Size (Male)	Clamping Range Ø min-max mm	Outer Thread Length TL mm	Spanner Width		Outer Ø D mm	Inner Ø ID mm	max. Height H mm	Part Number	Minimum Order Quantity
			Cap SW Cap mm	Bottom SW Bottom mm					
M12x1,5	3,0 - 6,5	6,0	14	7	15,6	6,7	22,0	BMFG-0S	250
M16x1,5	5,0 - 10,0	7,0	18	10	20,2	10,3	23,5	BMFG-01S	250
M20x1,5	6,0 - 12,0	10,0	22	13	24,1	12,3	27,0	BMFG-02S	250
M25x1,5	12,0 - 17,0	14,0	28	17	30,1	17,3	29,5	BMFG-03S	250

Hygienic Cable Gland Tightening Tool

Technical Details

Material: Stainless Steel 1.4305 (AISI 303)



Tightening Tool

For Gland Size	Allen Screw SW a mm	Spanner Width SW b mm	Height h mm	Part Number	Minimum Order Quantity
M12	5,0	7	5,0	BMFGT-01	250
M16	6,0	10	5,0	BMFGT-02	250
M20	8,0	13	8,0	BMFGT-03	250
M25	10,0	17	8,0	BMFGT-04	250

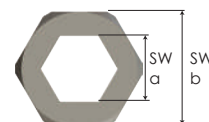

Hygienic Cable Gland Special Tool

Technical Details

Material: Stainless Steel 1.4305 (AISI 303)

Special Tool

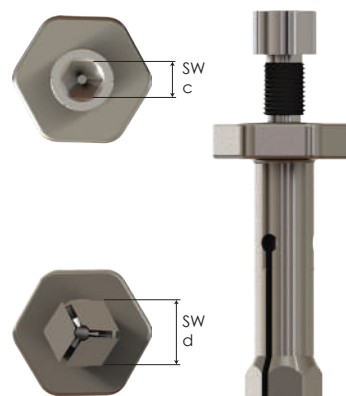

For Gland Size	Spanner Width		Part Number	Minimum Order Quantity
	SW c mm	SW d min-max mm		
M16	6,0	9,0 - 10,0	BMFGST-02	250
M20	8,0	11,0 - 13,0	BMFGST-03	250
M25	10,0	15,0 - 17,0	BMFGST-04	250



Hygienic Cable Glands, EMC Stainless Steel

EMC cable glands for hygienic requirements

- For EMC applications in manufacturing and packaging of food and pharmaceuticals, clean room technology, biotechnology, chemical industry.
- Long-lasting contact by high definition contact spring.
- Moving spring contact offers reduced risk of sheath damage.
- Smooth finish prevents harmful micro organisms to adhere on the surface.
- No threads are exposed.
- Gasket material according to FDA guideline 21 CFR 177.2600.
- Cleaning of cable glands is easier, faster and less expensive.
- Reliable strain relief due to strain relief element separated from grommet.
- Suitable for high pressure steam cleaning.
- EMC lock nut included.
- Assembling tool included.

Technical Details		
Material	Body, Cap	Stainless steel 1.4305 (AISI 303)
	Clamp, Insert	POM
	Contact Spring	Special Copper Alloy
	Seal	TPE
Ingress Protection Rating	IP 68 - 5 Bar, 30 min	
	IP 69	
Operating Temperature	Permanent	-20 °C to +100 °C
	Intermittent	-40 °C to +150 °C
Cable Type	Shielded	
Thread Type	• Metric EN 60423	
	• Other thread types also available upon request.	
Accessories	• Lock nuts	
	• Dome plugs	
	• Assembling tools	
	• Manufactured according to DIN EN 62444/50262.	
Remarks	• We recommend the use of lock nuts to ensure IP rating for rough surfaces or through holes.	
	• Accessories must be ordered separately.	
	• Some approvals do not cover all sizes.	
	Note: Applications of most cable glands don't require same parameters applied to tests. For applications strictly acc. to the approval definitions please consult data sheet.	
Approvals	Note: When using special tool – do not damage contact springs.	
	Certificate Number	Standards
		4001820
	485TUM2016 No.15/2015	EHEDG-Doc. 2, 3rd edition, 2004,
	E-14047	EN62444

For more approvals: see our webpage.

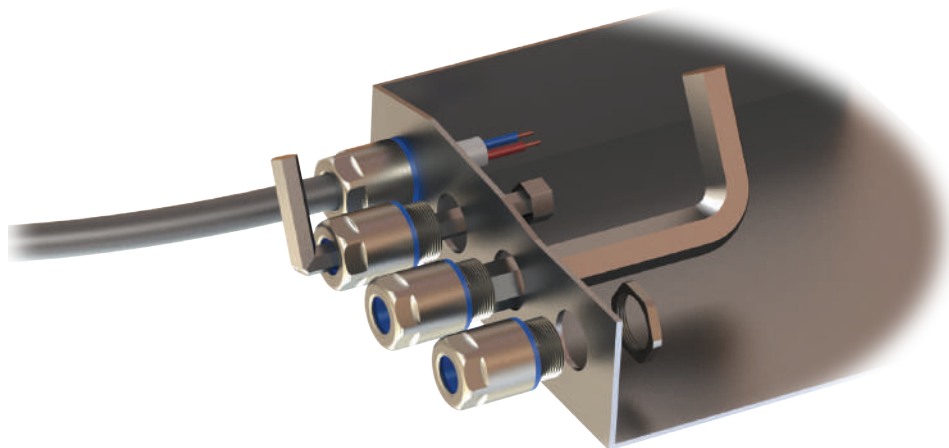
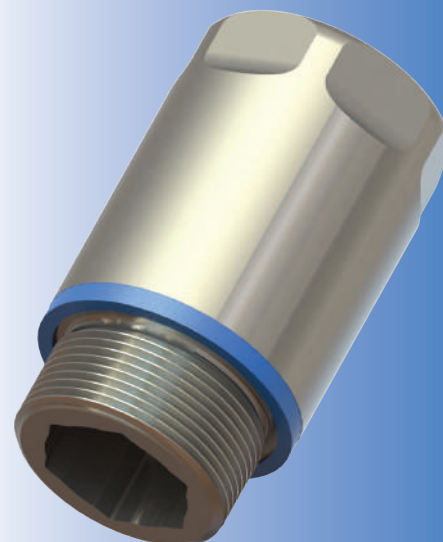

Hygienic Cable Glands, EMC Stainless Steel

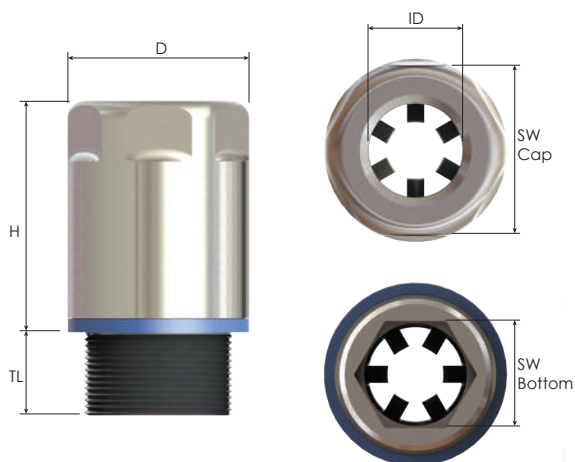

Thread Type **METRIC** acc. to EN 60423

Outer Thread Size (Male)	Clamping Range Ø min-max mm	Shield Ø Ø min-max mm	Outer Thread Length TL mm	Spanner Width		Outer Ø D mm	Inner Ø ID mm	max. Height H mm	Part Number	Minimum Order Quantity
				Cap SW Cap mm	Bottom SW Bottom mm					
M16x1,5	5,0 - 10,0	4,0 - 9,0	7,0	18	10	20,2	10,3	29,0	BMEFG-01	250
M20x1,5	6,0 - 12,0	5,0 - 11,0	10,0	22	13	24,1	12,3	33,5	BMEFG-02	250
M25x1,5	12,0 - 17,0	10,0 - 16,0	14,0	28	17	30,1	17,3	39,0	BMEFG-03	250

Hygienic Cable Gland Tightening Tool

Technical Details

Material: Stainless Steel 1.4305 (AISI 303)

Tightening Tool

For Gland Size	Allen Screw SW a mm	Outer Spanner Width SW b mm	Height h mm	Part Number	Minimum Order Quantity
M16	6,0	10	5,0	BMFGT-02	250
M20	8,0	13	8,0	BMFGT-03	250
M25	10,0	17	8,0	BMFGT-04	250

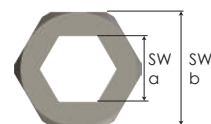

Hygienic Conduit Fittings Stainless Steel

Stainless steel Hygienic Conduit Fittings

- Stainless steel Hygienic Conduit Fittings are used in all areas where cleanliness is a necessity. Avoiding build-up of dirt is most important in the following industries:
 - Manufacturing and packaging of food and pharmaceuticals
 - Clean room technology
 - Biotechnology
 - Chemical industry
- Smooth finish prevents harmful micro organisms to adhere to the surface no threads are exposed.
- Cleaning of fittings is easier, faster and less expensive compared to traditional stainless steel cable glands.
- Upper protective cap avoids dirt to enter the system
- Suitable for high pressure steam cleaning

Technical Details		
Material	Body, Cap	Stainless steel 1.4404 (AISI 316L)
	Seal	TPE, according to FDA guideline 21 CFR 177.2600
Material	Pressure Ring	PA6 (Polyamide 6)
	O-ring	NBR
Ingress Protection Rating	Ferrule	Brass Nickel plated
		IP 68 (5 bar, 30 min), according to EN 60 529 IP 69K, according to DIN 40050-9
Operating Temperature	Permanent	-20 °C to +100 °C
	Intermittent	-40 °C to +150 °C
Thread Type	Metric, according to EN 60423 PG and NPT upon request	
Accessories	<ul style="list-style-type: none"> • Lock nuts 	
Remarks	<ul style="list-style-type: none"> • Accessories must be ordered separately. • O-ring available in Metric threads. • Smooth finish prevents harmful micro organisms to adhere to the surface. • No threads are exposed. • Cleaning of fittings is easier, faster and less expensive compared to traditional stainless steel cable glands. • Suitable for high pressure steam cleaning. • Manufacturing and packaging of food and pharmaceuticals. • Clean room technology, Biotechnology, Chemical industry... 	

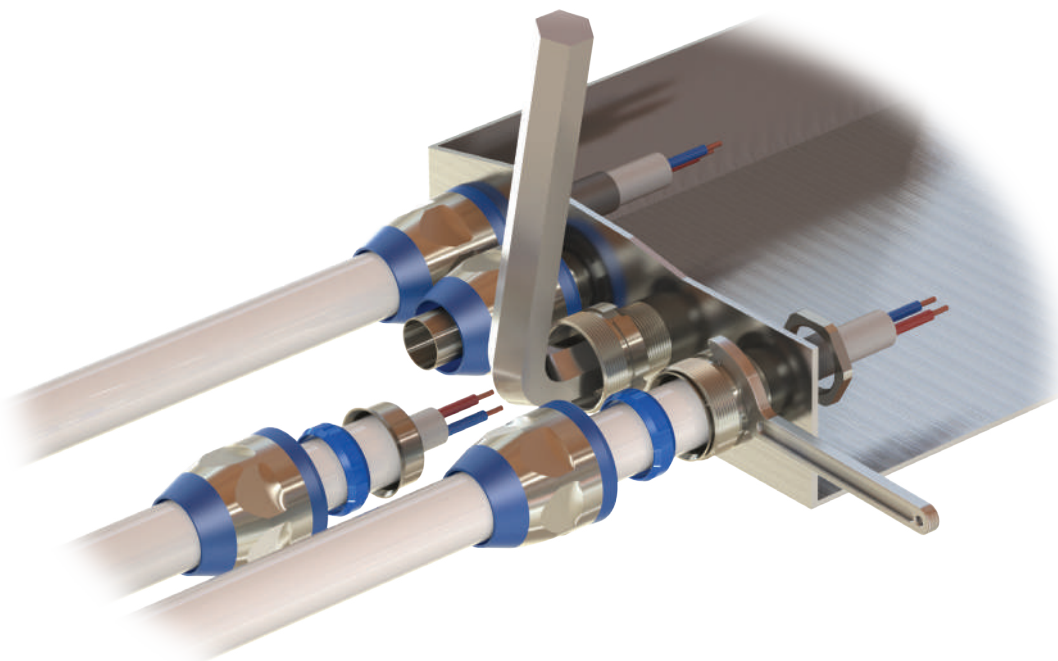

Hygienic Conduit Fittings Stainless Steel

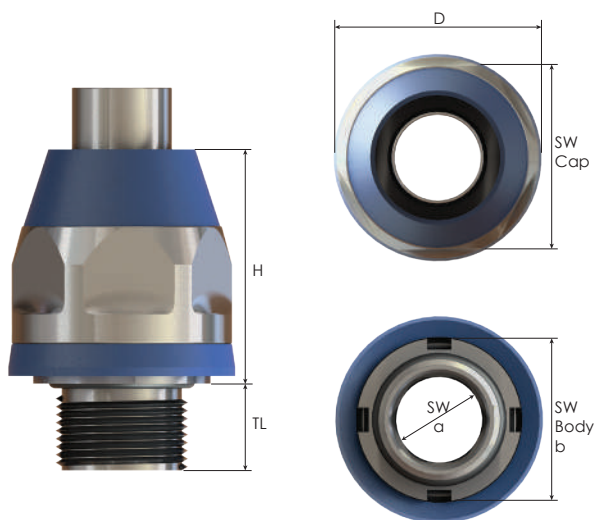

Thread Type **METRIC** acc. to EN 60423

Outer Thread Size (Male)	For Sealtite Nominal Size	Outer Thread Length	Spanner Width			Outer Ø	max. Height	Part Number	Minimum Order Quantity
			Cap	Allen Screw	Crescent Wrench				
		TL mm	SW Cap mm	SW a mm	SW Body b mm	D mm	H mm		
M16x1,5	3/8"	11,5	27	11	24	31,1	39,0	BMHF-01	400
M20x1,5	1/2"	13,0	30	14	27	34,0	39,5	BMHF-02	400
M25x1,5	3/4"	15,0	36	19	33	41,0	44,5	BMHF-03	200
M32x1,5	1"	15,0	46	25	42	52,7	55,0	BMHF-04	100
M40x1,5	1 1/4"	16,0	54	32	50	62,0	61,0	BMHF-05	60
M50x1,5	1 1/2"	18,0	63	36	58	70,0	65,5	BMHF-06	40
M63x1,5	2"	20,0	77	48	72	84,6	70,5	BMHF-07	20

Hygienic Conduit Fitting Tightening Tool

Technical Details

Material

Tightening Tool

For Gland Size	Allen Screw SW a mm	Spanner Ø SW b mm
M16	11,0	24,0
M20	14,0	27,0
M25	19,0	33,0
M32	25,0	42,0
M40	32,0	50,0
M50	36,0	58,0
M63	48,0	72,0

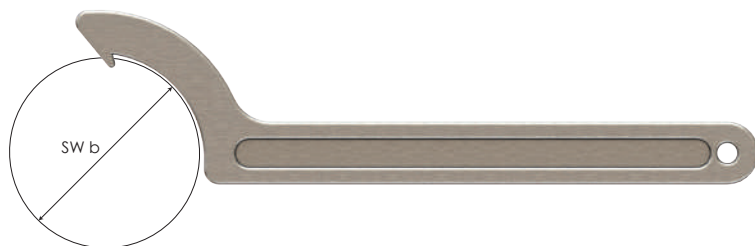

Further Accessories for Hygienic Glands & Fittings

Lock Nuts	
Stainless Steel Lock Nuts	
	68
Stainless Steel EMC Lock Nuts	
	69

Hygienic Glands & Fittings Applications

Food, Beverage and Pharmaceuticals Processing Machinery



Packaging for food, Beverage and Pharmaceuticals



Stainless Steel Control Cabinets and Monitoring Systems



Stainless Steel Control Enclosures for Food and Pharmaceuticals

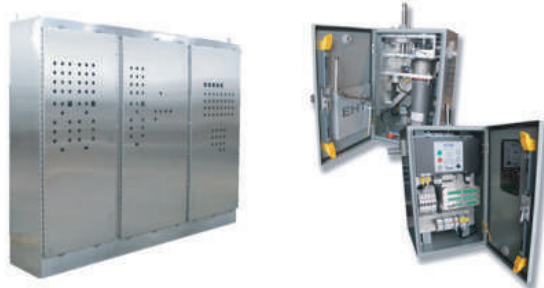

Plastic RIGID CONDUIT FITTINGS for Industrial Applications



Straight Fittings	96
Enclosure Couplers	97
Flexible Fittings	98
Straight Couplers	99
Conduit Union	100
Bend Couplers	101



Metal LIQUID TIGHT CONDUIT FITTINGS for Industrial Applications



Liquid Tight Conduit Fittings Straight, Male	102 - 103
Liquid Tight Conduit Fittings 45°, Male	104 - 105
Liquid Tight Conduit Fittings 90°, Male	106 - 107
Liquid Tight Conduit Fittings Straight, Female	108 - 109
Liquid Tight Conduit Fittings Straight, Cable Hose, Male	110 - 111
Straight Swivel Fittings	112
Applications	113

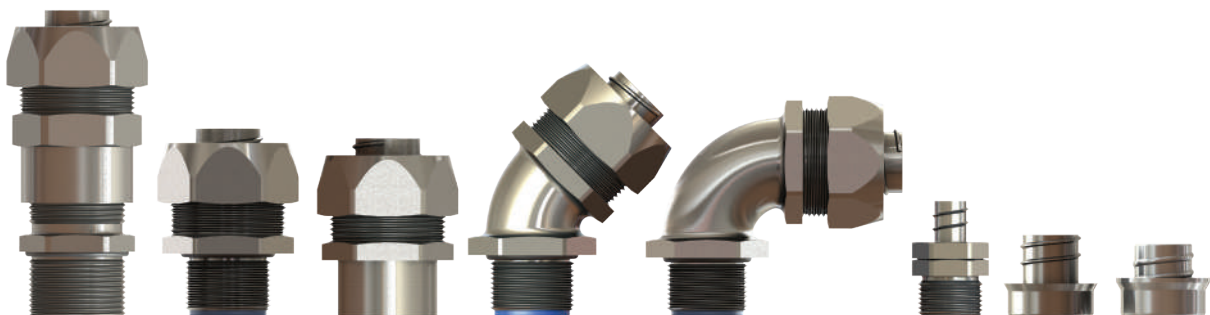

Straight Conduit Fittings Polyamide

Straight Conduit Fittings, Polyamide

- Halogen free.
- No toxic fumes when involved in a fire.
- For flexible spiral conduits.
- One side with standard metric or PG thread and special thread for conduit spiral on the other side.

Technical Details	
Material	Polyamide 6 Halogene free
Ingress Protection Rating	IP 54
Operating Temperature	Permanent
	-20 °C to +80 °C
Thread Type	Metric, according to EN 60423
	PG, according to DIN 40430
Accessories	<ul style="list-style-type: none"> • Lock nuts
Remarks	<ul style="list-style-type: none"> • We recommend the use of lock nuts to ensure IP rating for rough surfaces or through holes. • Accessories must be ordered separately.

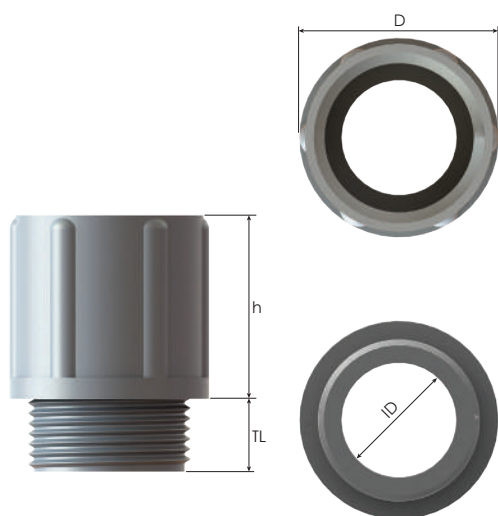

Thread Type **METRIC** acc. to EN 60423

Outer Thread Size (Male)	For Conduit Nominal Size	Outer Thread Length		Outer Ø D mm	Inner Ø ID mm	Height		Part Number	Minimum Order Quantity
		TL mm				h mm			
M12x1,5	12,8	8,0		17,4	7,0	21,2		BCM-05	3000
M16x1,5	15,0	8,0		20,0	10,0	21,3		BCM-01	2000
M20x1,5	19,0	8,0		24,1	15,0	24,5		BCM-02	2000
	21,0	9,0		26,0	13,0	25,5		BCM-03	1000
M25x1,5	22,0	10,0		28,9	18,0	25,5		BCM-04	500
M32x1,5	28,3	11,0		36,0	27,0	27,5		BCM-05	500
M40x1,5	36,4	11,0		44,2	31,5	32,5		BCM-06	250
M50x1,5	46,2	14,0		54,1	40,5	39,8		BCM-07	250
M63x1,5	57,0	14,0		67,0	51,0	43,5		BCM-08	250

Thread Type **PG** acc. to DIN 40430

Outer Thread Size (Male)	For Conduit Nominal Size	Outer Thread Length		Outer Ø D mm	Inner Ø ID mm	Height		Part Number	Minimum Order Quantity
		TL mm				h mm			
PG 7	12,8	8		17,4	7,0	21,2		BCF-01	3000
PG 9	15,0	8		20,0	10,0	21,3		BCF-02	2000
PG 11	19,0	8		24,0	13,5	24,5		BCF-03	2000
PG 13,5	21,0	9		25,9	14,5	25,3		BCF-04	1500
PG 16	22,0	10		28,9	16,0	25,5		BCF-05	750
PG 21	28,3	11		36,0	21,5	27,5		BCF-06	500
PG 29	36,4	11		44,2	31,5	32,4		BCF-07	500
PG 36	46,2	14		53,0	41,0	39,9		BCF-08	250
PG 48	57,0	14		67,8	51,0	43,3		BCF-09	10

Enclosure Couplers Polyamide

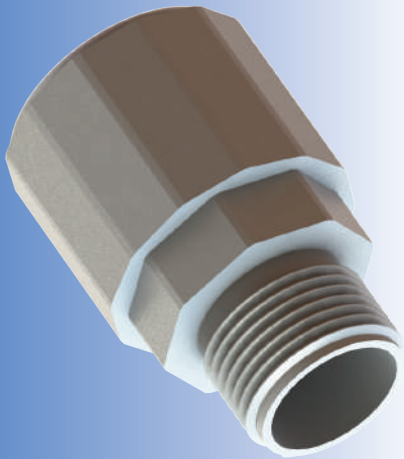

Enclosure Couplers

- Halogen free.
- No toxic fumes when involved in a fire.
- For conduit tubes.
- One side with standard metric threads and special fitting for conduit tubes on the other side.

Technical Details

Material	Fitting Seal	Polyamide 6 Halogene free TPE Halogene free
Ingress Protection Rating		IP 67
Operating Temperature	Permanent	-20 °C to +80 °C
Thread Type		Metric, according to EN 60423 and EN 62444
Accessories		• Lock nuts
Remarks		• We recommend the use of lock nuts to ensure IP rating for rough surfaces or through holes. • Accessories must be ordered separately.

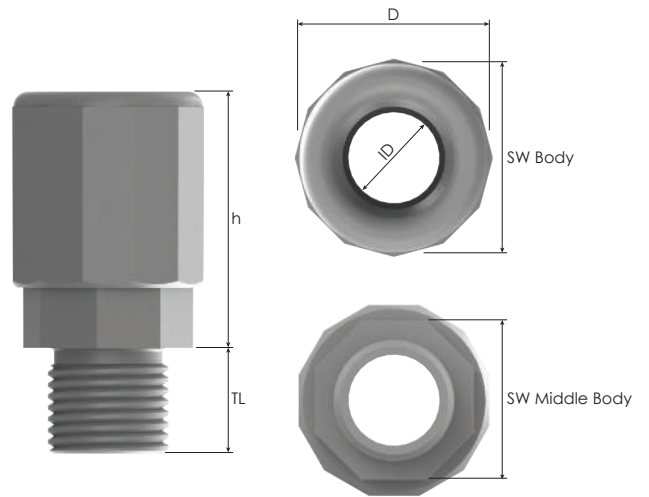

Thread Type **METRIC** acc. to EN 60423

Outer Thread Size (Male)	For Conduit Nominal Size	Outer Thread Length TL mm	Spanner Width		Outer Ø D mm	Inner Ø ID mm	Height H mm	Part Number	Minimum Order Quantity
			SW Body mm	SW Middle Body mm					
M16x1,5	16,0	14,0	26	21	26,3	16,5	34,5	BRCF-01	1500
M20x1,5	20,0	14,0	30	25	31,1	20,5	33,6	BRCF-02	1000
M25x1,5	25,0	14,0	35	30	35,7	25,1	34,7	BRCF-03	750
M32x1,5	32,0	14,0	42	37	43,0	32,6	34,5	BRCF-04	500
M40x1,5	40,0	19,0	50	45	51,5	40,4	42,2	BRCF-05	350
M50x1,5	50,0	19,0	61	55	63,4	50,7	42,1	BRCF-06	200
M63x1,5	63,0	19,0	74	68	77,2	58,2	42,2	BRCF-07	150

Flexible Fittings Polyamide

Flexible Fitting Set

- Halogen free.
- No toxic fumes when involved in a fire.
- For conduit tubes.
- For all kind of curves in electrical installations.
- Combination of two conduit unions with a flexible conduit.

Technical Details

Material	Fitting	Polyamide 6 Halogene free
	Seal	TPE Halogene free
Ingress Protection Rating	IP 67	
Operating Temperature	Permanent -20 °C to +80 °C	
Remarks	<ul style="list-style-type: none"> • It is the combination of two conduit unions with a suitable flexible conduit. • It may be used for all kind of curves in the electrical installation. • This set can be easily fitted with the right conduits. 	

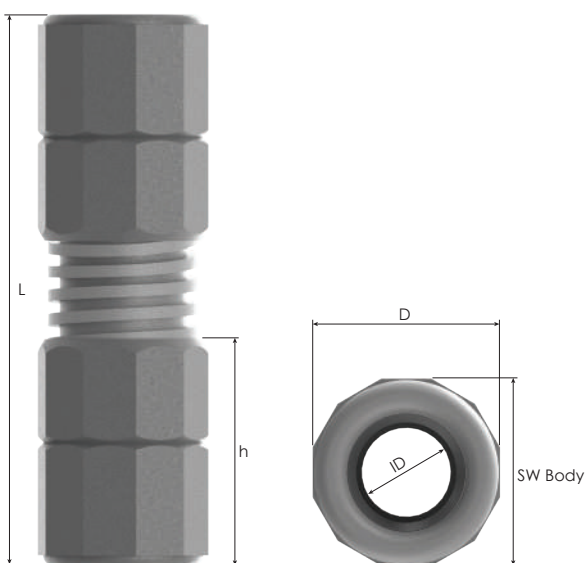
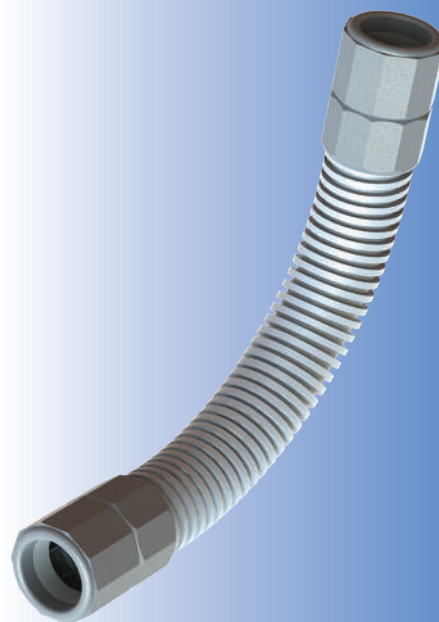

Flexible Fitting Set

Size	For Conduit Nominal Size	Spanner Width Body SW Body mm	Outer Ø D mm	Inner Ø ID mm	Height h mm	Total Length L mm	Part Number	Minimum Order Quantity
							RAL 7035 light grey	
M16	16,0	26	26,4	16,5	49,0	210	BRC90F-01	400
M20	20,0	30	31,3	20,4	47,7	240	BRC90F-02	250
M25	25,0	35	36,0	25,3	49,0	290	BRC90F-03	160
M32	32,0	42	43,4	32,2	48,7	400	BRC90F-04	70
M40	40,0	50	52,0	40,5	61,5	420	BRC90F-05	50
M50	50,0	62	63,3	50,5	61,5	440	BRC90F-06	30

Straight Couplers Polyamide

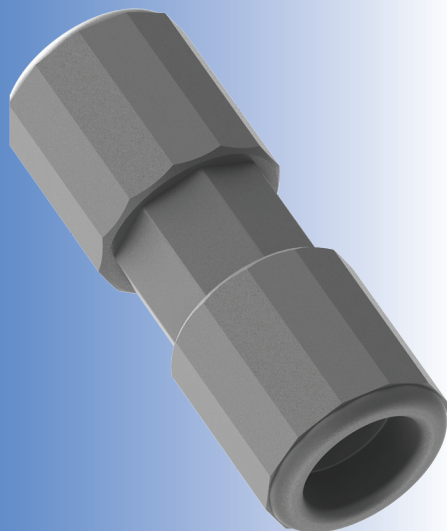

Straight Coupling

- Halogen free.
- No toxic fumes when involved in a fire.
- For connecting two conduit tubes.

Technical Details

Material	Fitting	Polyamide 6 Halogene free
	Seal	TPE Halogene free
Ingress Protection Rating	IP 67	
Operating Temperature	Permanent	
	-20 °C to +80 °C	

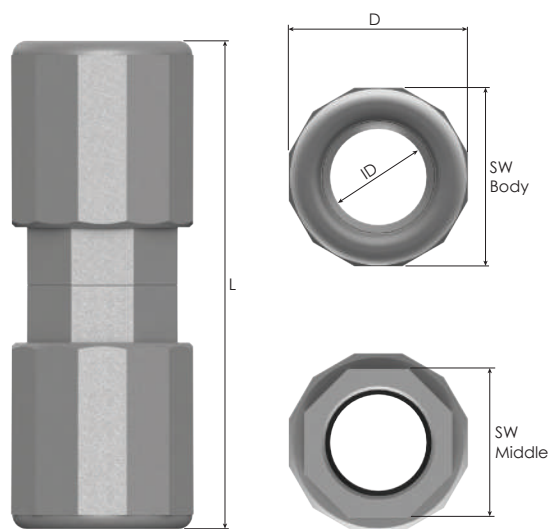

Straight Couplers

Size	For Conduit Nominal Size	Spanner Width		Outer Ø	Inner Ø	Height	Part Number	Minimum Order Quantity
		Body	Middle					
		SW Body mm	SW Middle mm	D mm	ID mm	L mm	RAL 7035 light grey	
M16	16,0	26	21	26,3	16,3	68,8	BRCC-01	1000
M20	20,0	30	25	31,4	20,3	67,3	BRCC-02	650
M25	25,0	35	30	36,0	25,3	69,0	BRCC-03	600
M32	32,0	42	37	43,5	32,2	69,5	BRCC-04	400
M40	40,0	50	45	52,0	40,4	85,0	BRCC-05	250
M50	50,0	62	55	63,3	50,0	84,5	BRCC-06	150

Conduit Union Polyamide

Conduit Union

- Halogen free.
- No toxic fumes when involved in a fire.
- For connecting flexible conduits with conduit tubes.

Technical Details

Material	Fitting Seal	Polyamide 6 Halogene free TPE Halogene free
Ingress Protection Rating		IP 67
Operating Temperature		Permanent -20 °C to +80 °C

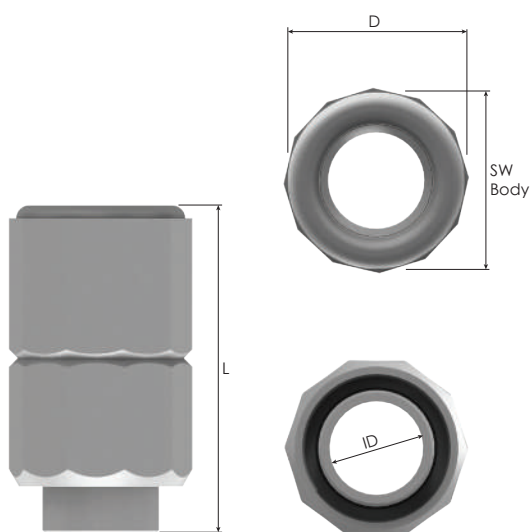
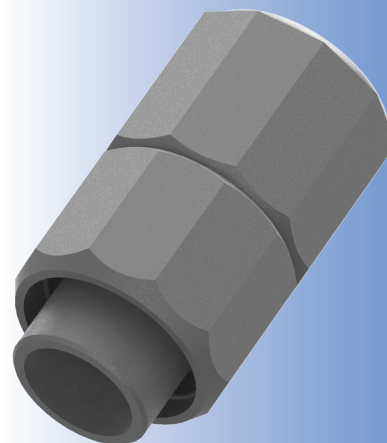

Conduit Union

Size	For Conduit Nominal Size	Spanner Width Body SW Body mm	Outer Ø D mm	Inner Ø ID mm	Total Length L mm	Part Number	Minimum Order Quantity
						RAL 7035 light grey	
M16	16,0	26	26,4	12,0	49,0	BRCM-01	1500
M20	20,0	30	31,0	16,0	47,7	BRCM-02	1000
M25	25,0	35	36,0	20,5	49,0	BRCM-03	750
M32	32,0	42	43,4	26,0	48,7	BRCM-04	500
M40	40,0	50	52,0	33,5	61,5	BRCM-05	300
M50	50,0	62	63,3	44,0	61,5	BRCM-06	200

Bend Couplers Polyamide

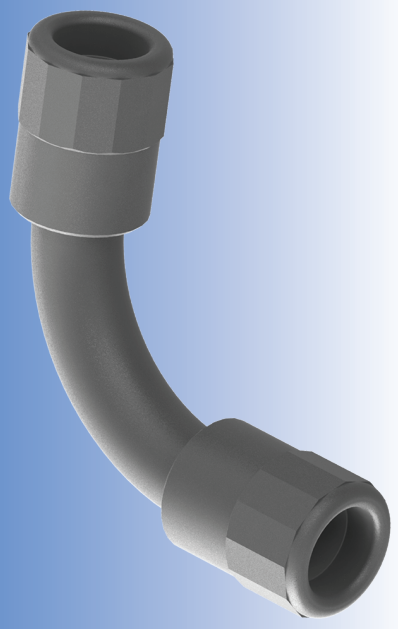

Bend Couplers

- Halogen free.
- No toxic fumes when involved in a fire.
- For connecting two conduit tubes by a 90° tube.

Technical Details

Material	Fitting	Polyamide 6 Halogene free
	Seal	TPE V0 Halogene free
Ingress Protection Rating	IP 67	
Operating Temperature	Permanent	
	-20 °C to +80 °C	

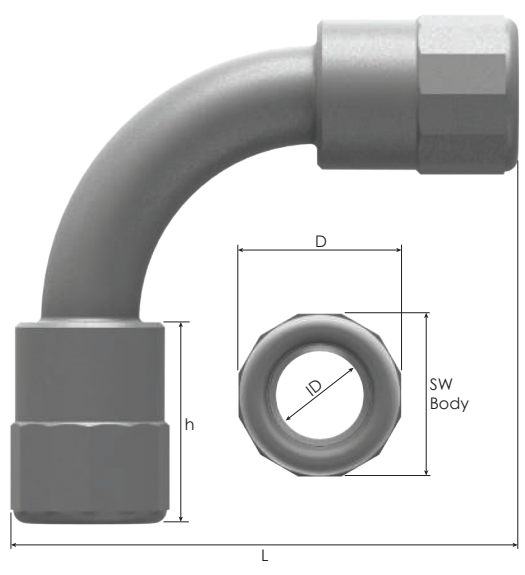

Bend Coupling

Size	For Conduit Nominal Size	Spanner Width Body SW Body mm	Outer Ø D mm	Inner Ø ID mm	Height h mm	Total Length L mm	Part Number	Minimum Order Quantity
							RAL 7035 light grey	
M16	16,0	26	26,4	16,4	32,8	78,0	BRC90R-01	600
M20	20,0	30	31,0	20,4	32,5	90,0	BRC90R-02	400
M25	25,0	35	36,0	25,4	32,5	107,0	BRC90R-03	250
M32	32,0	42	43,3	32,0	32,8	114,0	BRC90R-04	160
M40	40,0	50	52,0	40,2	32,8	138,0	BRC90R-05	90

Straight Liquid Tight Conduit Fittings Male, Brass

Liquid Tight Conduit Fittings Straight (Male), Brass

- Fittings for Sealrite conduits.
- For metal machines and housings.
- For standard industrial applications in harsh environments.
- Great corrosion protection.
- Easy assembly.
- High quality strain relief and sealing, reliable performance for standard industrial applications.

Technical Details

	Body, Cap	Brass Nickel plated		
	Ferrule	Brass Nickel plated or Steel zinc plated		
Material	Prot.Bushing	Polyamide 6 V2	Metric	PG
	Seal Ring	Polyamide 6 V2		
	O-Ring	NBR		
Ingress Protection Rating		IP 65		
		IP 66		
Operating Temperature	Permanent	-45 °C to +105 °C		
Cable Type	Non armoured			
Thread Type	<ul style="list-style-type: none"> • Metric EN 60423 • PG DIN 40430 • NPT ANSI B1.20.1 			
Accessories	<ul style="list-style-type: none"> • Lock nuts • Also available in Stainless Steel 			
Remarks	<ul style="list-style-type: none"> • O-ring available in Metric and PG threads. • Accessories must be ordered separately. 			

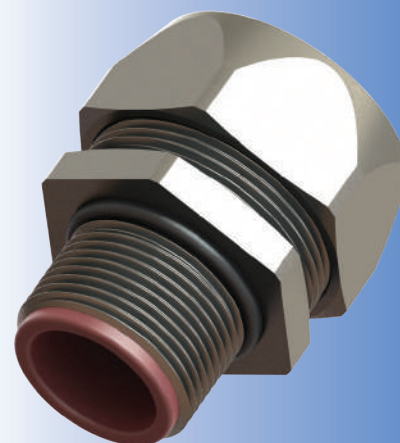

Straight Liquid Tight Conduit Fittings Male, Brass

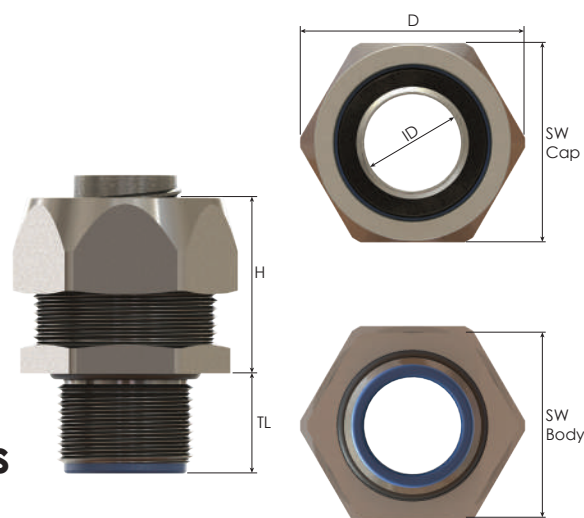

Thread Type acc. to EN 60423

Outer Thread Size (Male)	For Seallite Nominal Size	Outer Thread Length		Spanner Width		Outer Ø	Inner Ø	max. Height	Part Number	Minimum Order Quantity
		TL mm	SW Cap mm	SW Body mm	D mm					
M12x1,5	1/4"	10,0	22	20	24,5	5,2	23,0	BBFM-01	500	
M16x1,5	5/16"	11,5	26	24	29,0	8,3	25,5	BBFM-02(S)	500	
	3/8"	11,5	26	24	29,0	10,2	25,5	BBFM-02	500	
M20x1,5	3/8"	13,0	26	24	29,0	10,2	25,5	BBFM-03(S)	400	
	1/2"	13,0	29	27	32,7	13,5	26,5	BBFM-03	400	
M25x1,5	3/4"	15,0	35	33	39,0	18,5	27,0	BBFM-04	200	
M32x1,5	1"	15,0	45	43	50,0	23,5	34,0	BBFM-05	100	
M40x1,5	1 1/4"	16,0	54	52	60,0	31,8	38,5	BBFM-06	60	
M50x1,5	1 1/2"	18,0	63	60	69,3	36,8	40,5	BBFM-07	40	
M63x1,5	2"	20,0	77	74	85,0	47,8	47,0	BBFM-08	28	

Thread Type PG acc. to DIN 40430

Outer Thread Size (Male)	For Seallite Nominal Size	Outer Thread Length		Spanner Width		Outer Ø	Inner Ø	max. Height	Part Number	Minimum Order Quantity
		TL mm	SW Cap mm	SW Body mm	D mm					
PG 7	1/4"	10,0	22	20	24,5	5,2	23,0	BBFB-01	500	
PG 9	1/4"	10,0	22	20	24,5	5,2	23,0	BBFB-02	500	
	5/16"	10,0	22	20	24,5	8,3	22,5	BBFB-02(A)	500	
	5/16"	11,5	26	24	29,0	8,3	22,5	BBFB-02(B)	500	
	3/8"	11,5	26	24	29,0	10,2	25,5	BBFB-02(C)	500	
PG 11	3/8"	11,5	26	24	29,0	10,2	25,5	BBFB-03	500	
PG 13,5	3/8"	11,5	26	24	29,0	10,2	25,5	BBFB-04	500	
PG 16	1/2"	13,0	29	27	32,7	13,5	26,0	BBFB-05	400	
PG 21	3/4"	15,0	35	33	39,0	18,5	26,5	BBFB-06	200	
PG 29	1"	15,0	45	43	50,0	23,5	34,0	BBFB-07	100	
PG 36	1 1/4"	16,0	54	52	60,0	31,8	38,0	BBFB-08	60	
PG 42	1 1/2"	18,0	63	60	69,3	36,8	41,0	BBFB-09	40	
PG 48	2"	20,0	77	74	85,0	47,8	46,5	BBFB-10	28	

Thread Type NPT acc. to ANSI B1.20.1

Outer Thread Size (Male)	For Seallite Nominal Size	Outer Thread Length		Spanner Width		Outer Ø	Inner Ø	max. Height	Part Number	Minimum Order Quantity
		TL mm	SW Cap mm	SW Body mm	D mm					
NPT 1/4"	1/4"	10,0	22	20	24,5	5,2	23,0	BBFN-05	500	
NPT 3/8"	1/4"	10,0	22	20	24,5	10,2	23,0	BBFN-01(S)	500	
	3/8"	11,5	26	24	29,0	10,2	25,5	BBFN-01	500	
NPT 1/2"	3/8"	13,0	26	24	29,0	10,2	25,5	BBFN-02(S)	400	
	1/2"	13,0	29	27	32,7	13,5	26,0	BBFN-02	400	
NPT 3/4"	3/4"	15,0	35	33	39,0	18,5	27,0	BBFN-03	200	
NPT 1"	1"	15,0	45	43	50,0	23,5	33,5	BBFN-04	100	
NPT 1 1/4"	1 1/4"	16,0	54	52	60,0	31,8	37,5	BBFN-05	60	
NPT 1 1/2"	1 1/2"	18,0	63	60	69,3	36,8	40,5	BBFN-06	40	
NPT 2"	2"	20,0	77	74	85,0	47,8	47,5	BBFN-07	28	

45° Liquid Tight Conduit Fittings Male, Brass

45° Liquid Tight Conduit Fittings , Brass

- Fittings for Sealrite conduits.
- For metal machines and housings.
- For standard industrial applications in harsh environments.
- Great corrosion protection.
- Easy assembly.
- High quality strain relief and sealing, reliable performance for standard industrial applications.

Technical Details

	Body, Cap	Brass Nickel plated		
	Ferrule	Brass nickel plated or Steel zinc plated		
Material	Prot.Bushing	Polyamide 6 V2	Metric	PG
	Seal Ring	Polyamide 6 V2		NPT
	O-Ring	NBR		
Ingress Protection Rating		IP 65		
		IP 66		
Operating Temperature		Permanent		
		-45 °C to +105 °C		
Cable Type	Non armoured			
Thread Type		• Metric EN 60423		
		• PG DIN 40430		
		• NPT ANSI B1.20.1		
Accessories		• Lock nuts		
		• Also available in Stainless Steel		
Remarks		• O-ring available in Metric and PG threads.		
		• Accessories must be ordered separately.		

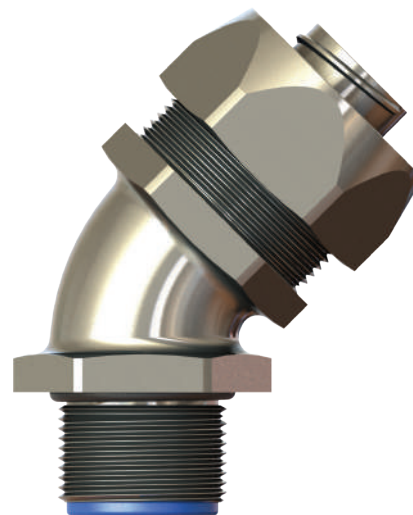
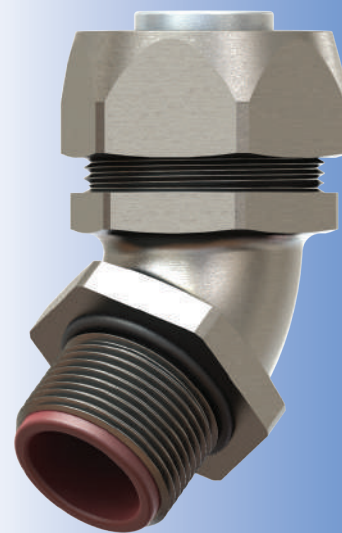

45° Liquid Tight Conduit Fittings Male, Brass

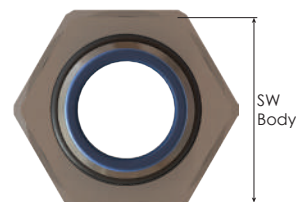
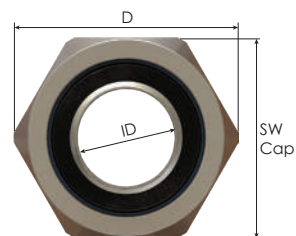
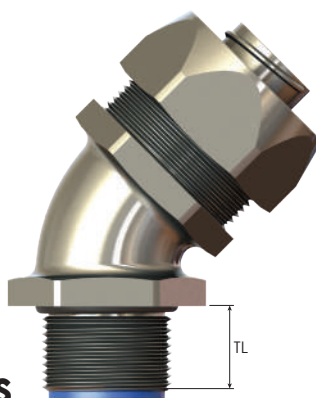

Thread Type **METRIC** acc. to EN 60423

Outer Thread Size (Male)	For Sealtite Nominal Size	Outer Thread Length	Spanner Width		Outer Ø	Inner Ø	Part Number	Minimum Order Quantity
			Cap	Body				
		TL mm	SW Cap mm	SW Body mm	D mm	ID mm		
M16x1,5	5/16"	11,5	26	22	29,0	8,3	BBFM-02(S) 45	200
	3/8"	11,5	26	22	29,0	10,2	BBFM-02 45	200
M20x1,5	3/8"	13,0	26	22	29,0	10,2	BBFM-03(S) 45	200
	1/2"	13,0	29	27	32,7	13,5	BBFM-03 45	200
M25x1,5	3/4"	15,0	35	33	39,0	18,5	BBFM-04 45	100
M32x1,5	1"	15,0	45	42	50,0	23,5	BBFM-05 45	70
M40x1,5	1 1/4"	16,0	54	51	60,0	31,8	BBFM-06 45	50
M50x1,5	1 1/2"	18,0	63	60	69,3	36,8	BBFM-07 45	24
M63x1,5	2"	20,0	77	74	85,0	47,8	BBFM-08 45	16

Thread Type **PG** acc. to DIN 40430

Outer Thread Size (Male)	For Sealtite Nominal Size	Outer Thread Length	Spanner Width		Outer Ø	Inner Ø	Part Number	Minimum Order Quantity
			Cap	Body				
		TL mm	SW Cap mm	SW Body mm	D mm	ID mm		
PG 11	5/16"	11,5	26	22	29,0	8,3	BBFB-03(S) 45	200
	3/8"	11,5	26	22	29,0	10,2	BBFB-03 45	200
PG 13,5	3/8"	11,5	26	22	29,0	10,2	BBFB-04 45	200
PG 16	1/2"	13,0	29	27	32,7	13,5	BBFB-05 45	200
PG 21	3/4"	15,0	35	33	39,0	18,5	BBFB-06 45	100
PG 29	1"	15,0	45	42	50,0	23,5	BBFB-07 45	70
PG 36	1 1/4"	16,0	54	51	60,0	31,8	BBFB-08 45	50
PG 42	1 1/2"	18,0	63	60	69,3	36,8	BBFB-09 45	24
PG 48	2"	20,0	77	74	85,0	47,8	BBFB-10 45	16

Thread Type **NPT** acc. to ANSI B1.20.1

Outer Thread Size (Male)	For Sealtite Nominal Size	Outer Thread Length	Spanner Width		Outer Ø	Inner Ø	Part Number	Minimum Order Quantity
			Cap	Body				
		TL mm	SW Cap mm	SW Body mm	D mm	ID mm		
NPT 1/2"	3/8"	13,0	26	22	29,0	10,2	BBFN-02(S) 45	200
	1/2"	13,0	29	27	32,7	13,5	BBFN-02 45	200
NPT 3/4"	3/4"	15,0	35	33	39,0	18,5	BBFN-03 45	100
NPT 1"	1"	15,0	45	42	50,0	23,5	BBFN-04 45	70
NPT 1 1/4"	1 1/4"	16,0	54	51	60,0	31,8	BBFN-05 45	50
NPT 1 1/2"	1 1/2"	18,0	63	60	69,3	36,8	BBFN-06 45	24
NPT 2"	2"	20,0	77	74	85,0	47,8	BBFN-07 45	16

90° Liquid Tight Conduit Fittings Male, Brass

90° Liquid Tight Conduit Fittings, Brass

- Fittings for Sealrite conduits.
- For metal machines and housings.
- For standard industrial applications in harsh environments.
- Great corrosion protection.
- Easy assembly.
- High quality strain relief and sealing, reliable performance for standard industrial applications.

Technical Details

	Body, Cap	Brass Nickel plated			
	Ferrule	Brass Nickel plated or Steel Zinc plated			
Material	Prof.Bushing	Polyamide 6 V2	Metric	PG	NPT
	Seal Ring	Polyamide 6 V2			
	O-Ring	NBR			
Ingress Protection Rating		IP 65			
		IP 66			
Operating Temperature	Permanent				
		-45 °C to +105 °C			
Cable Type	Non armoured				
Thread Type		• Metric EN 60423			
		• PG DIN 40430			
		• NPT ANSI B1.20.1			
Accessories	• Lock nuts				
Remarks		• Also available in Stainless Steel			
		• O-ring only available in Metric and PG threads.			
		• Accessories must be ordered separately.			

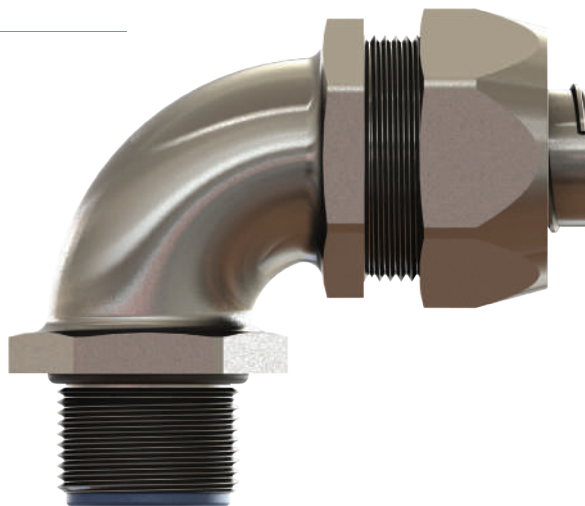

90° Liquid Tight Conduit Fittings Male, Brass



Thread Type **METRIC** acc. to EN 60423

Outer Thread Size (Male)	For Sealrite Nominal Size	Outer Thread Length	Spanner Width		Outer Ø	Inner Ø	Part Number	Minimum Order Quantity
			Cap	Body				
		TL mm	SW Cap mm	SW Body mm	D mm	ID mm		
M16x1,5	5/16"	11,5	26	22	29,0	8,3	BBFM-02(S) 90	200
	3/8"	11,5	26	22	29,0	10,2	BBFM-02 90	200
M20x1,5	3/8"	13,0	26	22	29,0	10,2	BBFM-03(S) 90	200
	1/2"	13,0	29	27	32,7	13,5	BBFM-03 90	200
M25x1,5	3/4"	15,0	35	33	39,0	18,5	BBFM-04 90	100
M32x1,5	1"	15,0	45	42	50,0	23,5	BBFM-05 90	70
M40x1,5	1 1/4"	16,0	54	51	60,0	31,8	BBFM-06 90	50
M50x1,5	1 1/2"	18,0	63	60	69,3	36,8	BBFM-07 90	24
M63x1,5	2"	20,0	77	74	85,0	47,8	BBFM-08 90	16

Thread Type **PG** acc. to DIN 40430

Outer Thread Size (Male)	For Sealrite Nominal Size	Outer Thread Length	Spanner Width		Outer Ø	Inner Ø	Part Number	Minimum Order Quantity
			Cap	Body				
		TL mm	SW Cap mm	SW Body mm	D mm	ID mm		
PG 11	5/16"	11,5	26	22	29,0	8,3	BBFB-03(S) 90	200
	3/8"	11,5	26	22	29,0	10,2	BBFB-03 90	200
PG 13,5	3/8"	11,5	26	22	29,0	10,2	BBFB-04 90	200
PG 16	1/2"	13,0	29	27	32,7	13,5	BBFB-05 90	200
PG 21	3/4"	15,0	35	33	39,0	18,5	BBFB-06 90	100
PG 29	1"	15,0	45	42	50,0	23,5	BBFB-07 90	70
PG 36	1 1/4"	16,0	54	51	60,0	31,8	BBFB-08 90	50
PG 42	1 1/2"	18,0	63	60	69,3	36,8	BBFB-09 90	24
PG 48	2"	20,0	77	74	85,0	47,8	BBFB-10 90	16

Thread Type **NPT** acc. to ANSI B1.20.1

Outer Thread Size (Male)	For Sealrite Nominal Size	Outer Thread Length	Spanner Width		Outer Ø	Inner Ø	Part Number	Minimum Order Quantity
			Cap	Body				
		TL mm	SW Cap mm	SW Body mm	D mm	ID mm		
NPT 1/2"	3/8"	13,0	26	22	29,0	10,2	BBFN-02(S) 90	200
	1/2"	13,0	29	27	32,7	13,5	BBFN-02 90	200
NPT 3/4"	3/4"	15,0	35	33	39,0	18,5	BBFN-03 90	100
NPT 1"	1"	15,0	45	42	50,0	23,5	BBFN-04 90	70
NPT 1 1/4"	1 1/4"	16,0	54	51	60,0	31,8	BBFN-05 90	50
NPT 1 1/2"	1 1/2"	18,0	63	60	69,3	36,8	BBFN-06 90	24
NPT 2"	2"	20,0	77	74	85,0	47,8	BBFN-07 90	16

Straight Liquid Tight Conduit Fittings Female, Brass

Straight Liquid Tight Conduit Fittings, Female, Brass

- Fittings for Sealrite conduits.
- For metal machines and housings.
- For standard industrial applications in harsh environments.
- Great corrosion protection.
- Easy assembly.
- High quality strain relief and sealing, reliable performance for standard industrial applications.

Technical Details

Material	Body, Cap	Brass Nickel plated
	Ferrule	Brass Nickel plated or Steel Zinc plated
	Seal Ring	Polyamide 6 V2
	O-Ring	NBR
Ingress Protection Rating		IP 65
		IP 66
Operating Temperature	Permanent	
		-45 °C to +105 °C
Cable Type		Non armoured
Thread Type		• Metric EN 60423
		• PG DIN 40430
		• NPT ANSI B1.20.1

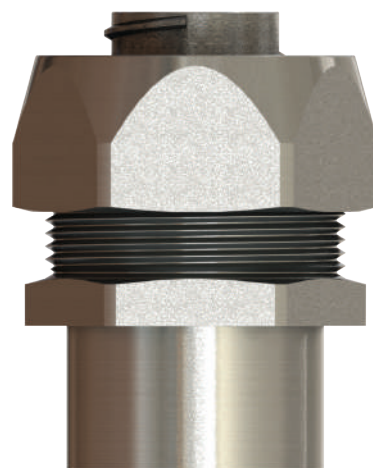
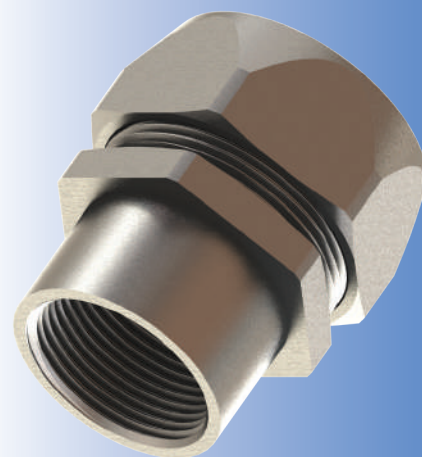

Straight Liquid Tight Conduit Fittings Female, Brass

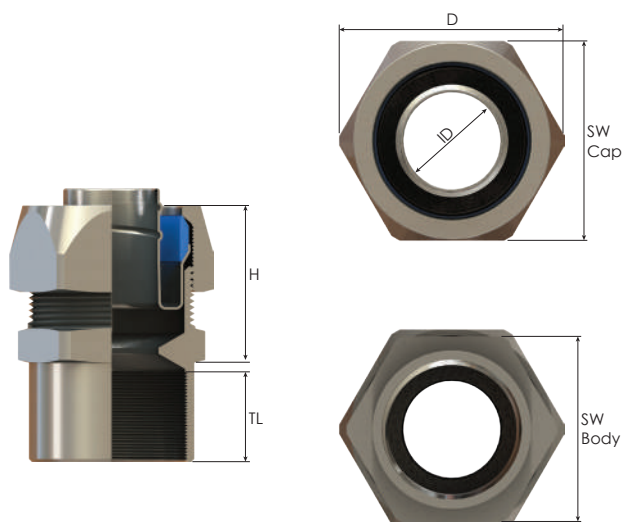

Thread Type **METRIC** acc. to EN 60423

Outer Thread Size (Female)	For Sealtite Nominal Size	Inner Thread Length	Spanner Width		Outer Ø	Inner Ø	max.Height	Part Number	Minimum Order Quantity
			SW Cap	SW Body					
		TL mm	SW Cap mm	SW Body mm	D mm	ID mm	H mm		
M16x1,5	5/16"	11,5	26,0	24,0	29,0	8,3	25,5	BBFM-02(S) F	500
	3/8"	11,5	26,0	24,0	29,0	10,2	26,0	BBFM-02 F	500
M20x1,5	1/2"	13,0	29,0	27,0	32,7	13,5	26,0	BBFM-03 F	400
M25x1,5	3/4"	15,0	35,0	33,0	39,0	18,5	26,5	BBFM-04 F	200
M32x1,5	1"	15,0	45,0	43,0	50,0	23,5	34,0	BBFM-05 F	100
M40x1,5	1 1/4"	16,0	54,0	52,0	60,0	31,8	37,5	BBFM-06 F	60
M50x1,5	1 1/2"	18,0	63,0	60,0	69,3	36,8	41,0	BBFM-07 F	40
M63x1,5	2"	20,0	77,0	74,0	85,0	47,8	48,0	BBFM-08 F	28

Thread Type **PG** acc. to DIN 40430

Outer Thread Size (Female)	For Sealtite Nominal Size	Inner Thread Length	Spanner Width		Outer Ø	Inner Ø	max.Height	Part Number	Minimum Order Quantity
			SW Cap	SW Body					
		TL mm	SW Cap mm	SW Body mm	D mm	ID mm	h mm		
PG 11	5/16"	11,5	26,0	24,0	29,0	8,3	25,5	BBFB-03(S) F	500
	3/8"	11,5	26,0	24,0	29,0	10,2	26,0	BBFB-03 F	500
PG 13,5	3/8"	11,5	26,0	24,0	29,0	10,2	26,0	BBFB-04 F	500
PG 16	1/2"	13,0	29,0	27,0	32,7	13,5	26,0	BBFB-05 F	400
PG 21	3/4"	15,0	35,0	33,0	39,0	18,5	26,5	BBFB-06 F	200
PG 29	1"	15,0	45,0	43,0	50,0	23,5	34,0	BBFB-07 F	100
PG 36	1 1/4"	16,0	54,0	52,0	60,0	31,8	38,0	BBFB-08 F	60
PG 42	1 1/2"	18,0	63,0	60,0	69,3	36,8	41,0	BBFB-09 F	40
PG 48	2"	20,0	77,0	74,0	85,0	47,8	48,0	BBFB-10 F	28

Thread Type **NPT** acc. to ANSI B1.20.1

Outer Thread Size (Female)	For Sealtite Nominal Size	Inner Thread Length	Spanner Width		Outer Ø	Inner Ø	max.Height	Part Number	Minimum Order Quantity
			SW Cap	SW Body					
		TL mm	SW Cap mm	SW Body mm	D mm	ID mm	h mm		
NPT 1/2	3/8"	13,0	26,0	24,0	29,0	10,2	26,0	BBFN-02(S) F	400
	1/2"	13,0	29,0	27,0	32,7	13,5	26,0	BBFN-02 F	400
NPT 3/4	3/4"	15,0	35,0	33,0	39,0	18,5	26,5	BBFN-03 F	200
NPT 1	1"	15,0	45,0	43,0	50,0	23,5	34,0	BBFN-04 F	100
NPT 1 1/4	1 1/4"	16,0	54,0	52,0	60,0	31,8	37,5	BBFN-05 F	60
NPT 1 1/2	1 1/2"	18,0	63,0	60,0	69,3	36,8	41,0	BBFN-06 F	40
NPT 2	2"	20,0	77,0	74,0	85,0	47,8	48,0	BBFN-07 F	28

Straight Liquid Tight Cable Hose Fittings Male, Brass

Liquid Tight Cable Hose Fittings (Male), Brass

- Conduit fittings with integrated cable gland – safe clamping and sealing of the cable.
- Fittings for Sealrite conduits.
- For metal machines and housings.
- For standard industrial applications in harsh environments.
- Great corrosion protection.
- Easy assembly.
- High quality strain relief and sealing, reliable performance for standard industrial applications.

Technical Details

Material	Body, Cap	Brass Nickel plated
	Clamping Insert	PA 6 (Polyamide 6)
	Seal	CR (Chloroprene)
	Ferrule	Brass Nickel plated or Steel Zinc plated
	Seal Ring	PA 6 (Polyamide 6)
	O-Ring	NBR
Ingress Protection Rating		IP 65 IP 66
Operating Temperature	Permanent	-20 °C to +100 °C
Cable Type		Non armoured
Thread Type		<ul style="list-style-type: none"> • Metric EN 60423 • PG DIN 40430
Accessories		<ul style="list-style-type: none"> • Lock nuts
Remarks		<ul style="list-style-type: none"> • O-ring available in Metric and PG threads. • Accessories must be ordered separately.



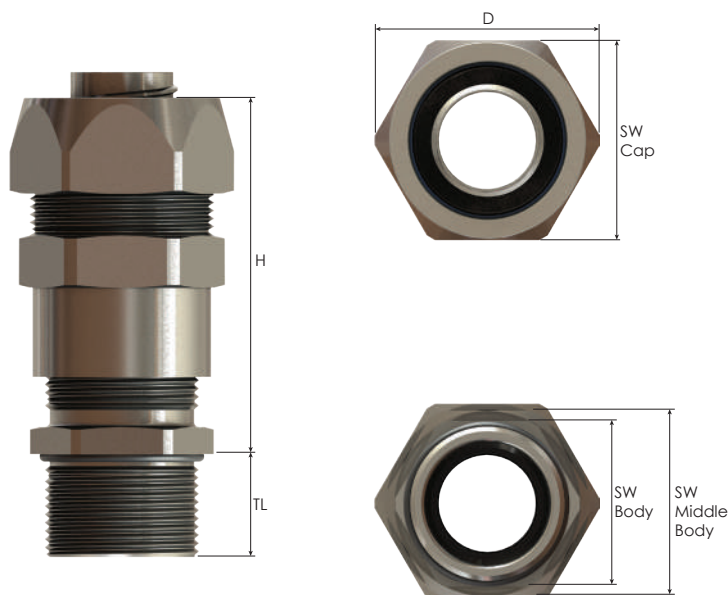

Straight Liquid Tight Cable Hose Fittings Male, Brass

Thread Type **METRIC** acc. to EN 60423

Outer Thread Size (Male)	For Sealrite Nominal Size	Clamping Range Ø min-max mm	Outer Thread Length TL mm	Spanner Width		Body SW Body mm	Outer Ø D mm	max. Height H mm	Part Number	Minimum Order Quantity
				Cap SW Cap mm	Middle Body SW Middle Body mm					
M16x1,5	5/16"	4,0 - 8,0	12,0	26	24	18	29,0	49,0	BBFM-02(S) CH	250
	3/8"	4,0 - 8,0	12,0	26	24	18	29,0	49,0	BBFM-02 CH	250
M20x1,5	3/8"	6,0 - 10,0	12,0	26	24	22	29,0	49,0	BBFM-03(S) CH	250
	1/2"	6,0 - 12,0	12,0	29	27	22	32,7	50,5	BBFM-03 CH	250
M25x1,5	3/4"	13,0 - 18,0	12,0	35	33	30	39,0	63,5	BBFM-04 CH	200
M32x1,5	1"	18,0 - 23,5	15,0	45	43	40	50,0	75,0	BBFM-05 CH	70
M40x1,5	1"	18,0 - 23,5	15,0	45	43	43	50,0	69,5	BBFM-06 CH	50

Thread Type **PG** acc. to DIN 40430

Outer Thread Size (Male)	For Sealrite Nominal Size	Clamping Range Ø min-max mm	Outer Thread Length TL mm	Spanner Width		Body SW Body mm	Outer Ø D mm	max. Height H mm	Part Number	Minimum Order Quantity
				Cap SW Cap mm	Middle Body SW Middle Body mm					
PG 9	5/16"	4,0 - 8,0	12,0	26,0	24,0	17,0	29,0	48,5	BBFB-02(S) CH	250
	3/8"	4,0 - 8,0	12,0	26,0	24,0	17,0	29,0	48,5	BBFB-02 CH	250
PG 11	3/8"	5,0 - 10,0	15,0	26,0	24,0	20,0	29,0	51,0	BBFB-03 CH	250
	3/8"	6,0 - 10,0	15,0	26,0	24,0	22,0	29,0	49,0	BBFB-04 CH	200
PG 13,5	1/2"	6,0 - 12,0	15,0	29,0	27,0	22,0	32,7	50,5	BBFB-04(S) CH	200
	1/2"	10,0 - 13,5	15,0	29,0	27,0	24,0	32,7	53,5	BBFB-05 CH	200
PG 21	3/4"	13,0 - 18,0	15,0	35,0	33,0	30,0	39,0	59,0	BBFB-06 CH	100
PG 29	1"	18,0 - 23,5	15,0	45,0	43,0	40,0	50,0	70,0	BBFB-07 CH	70

Straight Swivel Fittings Male

Technical Details	
Material	Stainless Steel AISI 303
Thread Type	Metric acc. to EN 60423

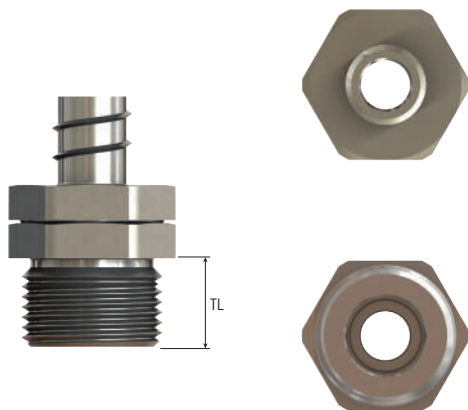

Swivel Fittings					
Outer Thread Size (Male)	For Sealrite Nominal Size	Outer Thread Length TL mm	Outer Ø D mm	Part Number	Minimum Order Quantity
M12x1,5	1/4"	8,0	15,5	BMSSW-0S	1000
M16x1,5	1/4"	10,0	18,9	BMSSW-01	500



Rigid & Liquid Tight Conduit Fittings Applications

Machine Tools



Transformer Connections



Wet and Corrosive environments, including power generations, petrochemical, paper mills, food, beverage, pharmaceutical plants and anywhere high performance is required.

Console Wiring



Computer Power Distribution



Motor Applications



Oiltight, Liquidtight or Raintight box and enclosures



Air Conditioning and Heating



Outdoor Lighting



Flexibility and Protection against entry liquids, vapors or solids, such as machine tool building, robotic assembly

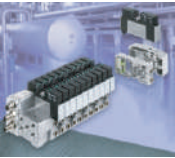

Polyamide ADAPTORS & PLUGS for Industrial Applications



Plugs

Round Plugs	116
Hexagonal Plugs	117
Modular Plugs	118

Metal ADAPTORS & PLUGS for Industrial Applications

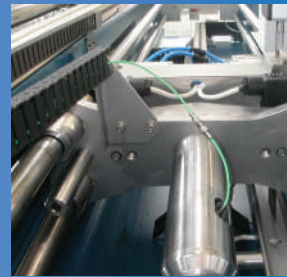
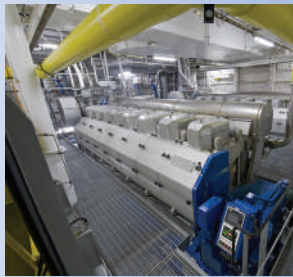

Adaptors

Enlargers, Brass
Adaptors, Brass
Reducers, Brass

119
120 - 121
122 - 123

Plugs

Hexagonal Plugs
Round Plugs

124
125

Plugs, Round Polyamide

Plugs, round

- For standard industrial applications.
- Seal of housing hole when no cable gland is used.
- Phillips-head version.

Technical Details

Material	Body	PA 6 (Polyamide 6)
	O-ring	NBR
Flammability	V2 according to UL94	
Ingress Protection Rating	IP 68 - 5 Bar, 30 min	
Operating Temperature	Permanent	-20 °C to +100 °C
	Intermittent	-30 °C to +150 °C
Thread Type	<ul style="list-style-type: none"> • Metric EN 60423 • PG DIN 40430 	
Accessories	<ul style="list-style-type: none"> • Lock nuts 	
Remarks	<ul style="list-style-type: none"> • We recommend the use of lock nuts for through holes. 	

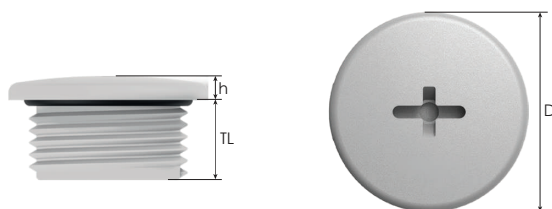

Thread Type **METRIC** acc. to EN 60423

Outer Thread		Outer Ø		Height	Part Number			Minimum Order Quantity
Size (Male)	Length TL mm	D mm	h mm	RAL 7035	RAL 7001	RAL 9005		
				light grey	grey	black		
M12x1,5	6,0	15,0	3,0	BMBS-1S(Y)(+)(TL6)	BMBS-0S(Y)(+)(TL6)	BMBS-2S(Y)(+)(TL6)	10000	
	10,0	15,0	3,0	BMBS-1S(Y)(+)(TL10)	BMBS-0S(Y)(+)(TL10)	BMBS-2S(Y)(+)(TL10)	10000	
M16x1,5	6,0	19,5	3,4	BMBS-11(Y)(+)(TL6)	BMBS-01(Y)(+)(TL6)	BMBS-21(Y)(+)(TL6)	10000	
	10,0	19,5	3,4	BMBS-11(Y)(+)(TL10)	BMBS-01(Y)(+)(TL10)	BMBS-21(Y)(+)(TL10)	10000	
M20x1,5	6,0	25,0	3,0	BMBS-12(Y)(+)(TL6)	BMBS-02(Y)(+)(TL6)	BMBS-22(Y)(+)(TL6)	5000	
	10,0	25,0	3,0	BMBS-12(Y)(+)(TL10)	BMBS-02(Y)(+)(TL10)	BMBS-22(Y)(+)(TL10)	5000	
M25x1,5	6,0	30,0	4,0	BMBS-13(Y)(+)(TL6)	BMBS-03(Y)(+)(TL6)	BMBS-23(Y)(+)(TL6)	2500	
	10,0	30,0	4,0	BMBS-13(Y)(+)(TL10)	BMBS-03(Y)(+)(TL10)	BMBS-23(Y)(+)(TL10)	2500	
	15,0	30,0	4,0	BMBS-13(Y)(+)(TL15)	BMBS-03(Y)(+)(TL15)	BMBS-23(Y)(+)(TL15)	2500	
M32x1,5	8,0	37,0	4,0	BMBS-14(Y)(+)(TL8)	BMBS-04(Y)(+)(TL8)	BMBS-24(Y)(+)(TL8)	2000	
	10,0	37,0	4,0	BMBS-14(Y)(+)(TL10)	BMBS-04(Y)(+)(TL10)	BMBS-24(Y)(+)(TL10)	2000	
M40x1,5	8,0	46,0	4,5	BMBS-15(Y)(+)(TL8)	BMBS-05(Y)(+)(TL8)	BMBS-25(Y)(+)(TL8)	1500	
	10,0	46,0	4,5	BMBS-15(Y)(+)(TL10)	BMBS-05(Y)(+)(TL10)	BMBS-25(Y)(+)(TL10)	1500	
M50x1,5	10,0	54,9	3,7	BMBS-16(Y)(+)(TL10)	BMBS-06(Y)(+)(TL10)	BMBS-26(Y)(+)(TL10)	1000	

Thread Type **PG** acc. to DIN 40430

Outer Thread		Outer Ø		Height	Part Number			Minimum Order Quantity
Size (Male)	Length TL mm	D mm	h mm	RAL 7035	RAL 7001	RAL 9005		
				light grey	grey	black		
PG 7	6,0	15,0	3,0	BBS-11(Y)(+)(TL6)	BBS-01(Y)(+)(TL6)	BBS-21(Y)(+)(TL6)	10000	
	10,0	15,0	3,0	BBS-11(Y)(+)(TL10)	BBS-01(Y)(+)(TL10)	BBS-21(Y)(+)(TL10)	10000	
PG 9	6,0	19,5	3,0	BBS-12(Y)(+)(TL6)	BBS-02(Y)(+)(TL6)	BBS-22(Y)(+)(TL6)	10000	
	10,0	19,5	3,0	BBS-12(Y)(+)(TL10)	BBS-02(Y)(+)(TL10)	BBS-22(Y)(+)(TL10)	10000	
PG 11	6,0	22,0	3,0	BBS-13(Y)(+)(TL6)	BBS-03(Y)(+)(TL6)	BBS-23(Y)(+)(TL6)	10000	
	10,0	22,0	3,0	BBS-13(Y)(+)(TL10)	BBS-03(Y)(+)(TL10)	BBS-23(Y)(+)(TL10)	10000	
PG 13,5	6,0	24,7	3,0	BBS-14(Y)(+)(TL6)	BBS-04(Y)(+)(TL6)	BBS-24(Y)(+)(TL6)	5000	
	10,0	24,7	3,0	BBS-14(Y)(+)(TL10)	BBS-04(Y)(+)(TL10)	BBS-24(Y)(+)(TL10)	5000	
PG 16	6,0	27,0	3,4	BBS-15(Y)(+)(TL6)	BBS-05(Y)(+)(TL6)	BBS-25(Y)(+)(TL6)	5000	
	10,0	27,0	3,4	BBS-15(Y)(+)(TL10)	BBS-05(Y)(+)(TL10)	BBS-25(Y)(+)(TL10)	5000	
PG 21	8,0	33,0	4,0	BBS-16(Y)(+)(TL8)	BBS-06(Y)(+)(TL8)	BBS-26(Y)(+)(TL8)	2500	
	10,0	33,0	4,0	BBS-16(Y)(+)(TL10)	BBS-06(Y)(+)(TL10)	BBS-26(Y)(+)(TL10)	2500	
PG 29	8,0	44,0	3,2	BBS-17(Y)(+)(TL8)	BBS-07(Y)(+)(TL8)	BBS-27(Y)(+)(TL8)	2000	
	10,0	44,0	3,2	BBS-17(Y)(+)(TL10)	BBS-07(Y)(+)(TL10)	BBS-27(Y)(+)(TL10)	2000	
PG 36	10,0	55,0	3,7	BBS-18(Y)(+)(TL10)	BBS-08(Y)(+)(TL10)	BBS-28(Y)(+)(TL10)	2000	

Plugs, Hexagonal Polyamide

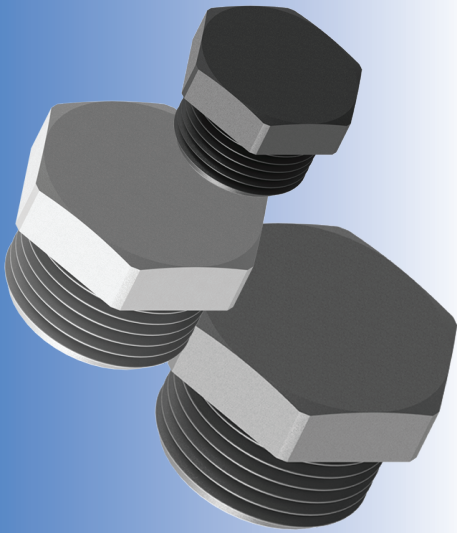

Plugs, hexagonal

- For standard industrial applications.
- Seal of housing hole when no cable gland is used.
- To fasten with spanner.

Technical Details

Material	PA 6 (Polyamide 6)	
Flammability	V2 according to UL94	
Ingress Protection Rating	IP 68 - 5 Bar, 30 min	
Operating Temperature	Permanent	Intermittent
	-20 °C to +100 °C	-30 °C to +150 °C
Thread Type	<ul style="list-style-type: none"> • Metric EN 60423 • NPT ANSI B1.20.1 	
Accessories	<ul style="list-style-type: none"> • Lock nuts • Gaskets (Washers) 	
Remarks	<ul style="list-style-type: none"> • We recommend the use of lock nuts and gaskets to ensure IP rating for rough surfaces or through holes. • Accessories must be ordered separately. 	

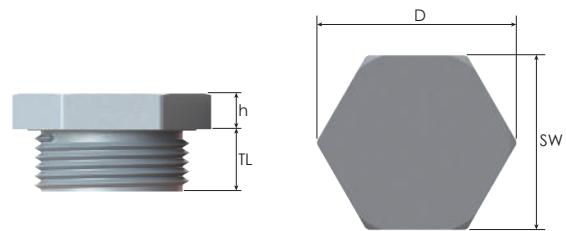

Thread Type METRIC acc. to EN 60423

Outer Thread Size (Male)	Length TL mm	Spanner Width SW mm	Outer Ø D mm	Height h mm	Part Number			Minimum Order Quantity
					RAL 7035 light grey	RAL 7001 grey	RAL 9005 black	
M12x1,5	10,0	15	17,0	5,0	BMBS-1S(A)(TL10)	BMBS-0S(A)(TL10)	BMBS-2S(A)(TL10)	10000
M16x1,5	11,0	19	22,0	4,3	BMBS-11(A)(TL11)	BMBS-01(A)(TL11)	BMBS-21(A)(TL11)	10000
	15,0	19	22,0	4,3	BMBS-11(A)(TL15)	BMBS-01(A)(TL15)	BMBS-21(A)(TL15)	10000
M20x1,5	11,0	23	26,0	6,0	BMBS-12(A)(TL11)	BMBS-02(A)(TL11)	BMBS-22(A)(TL11)	5000
	15,0	23	26,0	6,0	BMBS-12(A)(TL15)	BMBS-02(A)(TL15)	BMBS-22(A)(TL15)	5000
M25x1,5	10,0	28	32,0	5,8	BMBS-13(A)(TL10)	BMBS-03(A)(TL10)	BMBS-23(A)(TL10)	2500
	15,0	28	32,0	5,8	BMBS-13(A)(TL15)	BMBS-03(A)(TL15)	BMBS-23(A)(TL15)	2500
M32x1,5	15,0	36	41,5	7,8	BMBS-14(A)(TL15)	BMBS-04(A)(TL15)	BMBS-24(A)(TL15)	2000
M40x1,5	18,0	46	53,0	8,5	BMBS-15(A)(TL18)	BMBS-05(A)(TL18)	BMBS-25(A)(TL18)	1000
M50x1,5	18,0	55	63,5	9,5	BMBS-16(A)(TL18)	BMBS-06(A)(TL18)	BMBS-26(A)(TL18)	500
M63x1,5	18,0	69	79,5	9,5	BMBS-17(A)(TL18)	BMBS-07(A)(TL18)	BMBS-27(A)(TL18)	250

Thread Type NPT acc. to ANSI B1.20.1

Outer Thread Size (Male)	Length TL mm	Spanner Width SW mm	Outer Ø D mm	Height h mm	Part Number			Minimum Order Quantity
					RAL 7035 light grey	RAL 7001 grey	RAL 9005 black	
NPT 1/2"	15,0	23	26,0	6,0	BNBS-12(A)(TL15)	BNBS-02(A)(TL15)	BNBS-22(A)(TL15)	5000
NPT 3/4"	15,0	28	32,0	5,8	BNBS-13(A)(TL15)	BNBS-03(A)(TL15)	BNBS-23(A)(TL15)	2500
NPT 1"	15,0	36	41,0	7,8	BNBS-14(A)(TL15)	BNBS-04(A)(TL15)	BNBS-24(A)(TL15)	2000

Modular Plugs Polyamide

Polyamide plugs, front-side assembly, without thread

- For standard industrial applications.
- Snap-in assembly for non-threaded holes.
- Lock nuts have threads acc. to EN 60423 (metric) and acc. to DIN 40430 (PG).
- Replacing the modular plug: lock nut can be used for fixing the cable gland.

Technical Details

Material	Body	PA 6 (Polyamide 6)	
	Gasket	CR (Chloroprene)	
	Lock Nut	PA 6 GF 30 (Polyamide 6, 30% Glass Fiber Reinforced)	
Flammability	V2 according to UL94		
Protection Class	IP 68 - 5 Bar, 30 min		
Operating Temperature	Permanent	-20 °C to +100 °C	Intermittent
			-30 °C to +150 °C
Remarks	Other colours on request:		
	• RAL 5015 (blue)		
	• RAL 9003 (white)		
	• RAL 3020 (red)		
Approvals	Certificate Number	Standards	
	SERCOVAM RES 107572	acc. to UL514B §8.26.7	

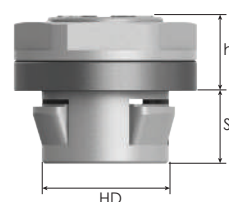
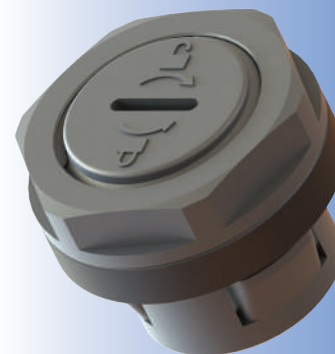

without thread - wall thickness E : 0,5 - 2,0 mm

Size	Snap Length SL mm	Ø SD mm	Hole Ø HD mm	Spanner Width SW mm	Outer Ø D mm	Height h mm	Part Number			Minimum Order Quantity
							RAL 7035	RAL 7001	RAL 9005	
							light grey	grey	black	
M12	9,0	11,9	12,2 - 12,4	18	19,5	12,0	BMPL-1S	BMPL-0S	BMPL-2S	5000
M20	9,0	19,9	20,2 - 20,4	26	28,6	13,5	BMPL-12	BMPL-02	BMPL-22	2500
M32	9,0	31,9	32,2 - 32,4	41	46,1	15,5	BMPL-14	BMPL-04	BMPL-24	1500
PG 16	9,0	22,4	22,7 - 22,9	30	33,0	13,5	BSPL-15	BSPL-05	BSPL-25	2000

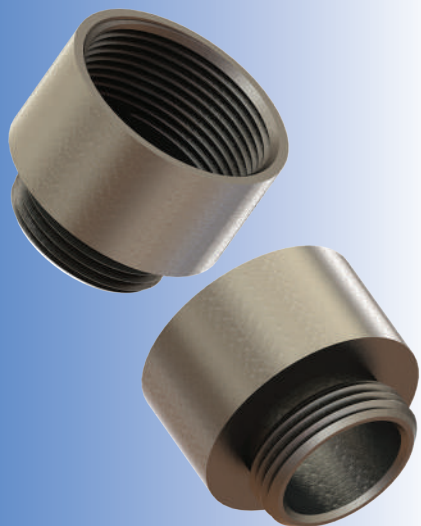

Enlargers for different thread sizes

- For metal machines and housings.
- Enlargers for the transition of different thread types and sizes.

Technical Details

Material	Brass Nickel plated, Stainless Steel
Thread Type	<ul style="list-style-type: none"> • Metric EN 60423 • PG DIN 40430
Accessories	<ul style="list-style-type: none"> • Lock nuts • Gaskets (Washers)
Remarks	<ul style="list-style-type: none"> • We recommend the use of lock nuts and gaskets to ensure IP rating for rough surfaces or through holes. • Accessories must be ordered separately.

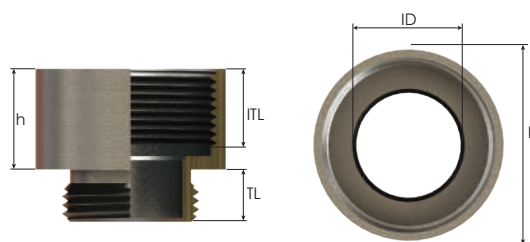

Thread Type **METRIC - METRIC** acc. to EN 60423

Outer Thread Size (Male)	Inner Thread Size (Female)	Outer Thread Length		Inner Ø	Outer Ø	Height	Part Number	Minimum Order Quantity
		TL mm	ITL mm					
M12x1,5	M16x1,5	6,0	7,0	8,0	18,0	9,0	IB-RB05M01M	189
M16x1,5	M20x1,5	6,0	10,0	12,0	22,0	11,6	IB-RB01M02M	189
M20x1,5	M25x1,5	7,0	8,5	16,0	27,0	10,5	IB-RB02M03M	189
M25x1,5	M32x1,5	8,0	9,5	20,5	34,0	11,5	IB-RB03M04M	105
M32x1,5	M40x1,5	8,0	8,5	26,0	42,0	14,5	IB-RB04M05M	70
M40x1,5	M50x1,5	8,0	13,5	26,0	54,0	17,0	IB-RB04M06M	40
M40x1,5	M50x1,5	8,0	15,0	35,5	52,0	19,5	IB-RB05M06M	24
M50x1,5	M63x1,5	9,0	9,5	45,0	65,0	22,5	IB-RB06M07M	20

Thread Type **PG - PG** acc. to DIN 40430

Outer Thread Size (Male)	Inner Thread Size (Female)	Outer Thread Length		Inner Ø	Outer Ø	Height	Part Number	Minimum Order Quantity
		TL mm	ITL mm					
PG 7	PG 9	5,0	5,0	8,0	17,0	10,0	IB-RB01P02P	189
PG 9	PG 11	6,0	7,0	11,5	20,0	10,5	IB-RB02P03P	189
	PG 13,5	6,0	9,0	11,5	22,0	11,5	IB-RB02P04P	189
PG 11	PG 13,5	6,0	8,5	13,8	22,0	11,5	IB-RB03P04P	189
	PG 16	6,5	8,5	13,8	24,0	10,5	IB-RB03P05P	189
	PG 21	6,5	10,0	13,8	30,0	14,5	IB-RB03P06P	189
PG 13,5	PG 16	6,5	8,5	16,5	24,0	10,5	IB-RB04P05P	189
	PG 21	6,5	10,0	16,5	30,0	14,5	IB-RB04P06P	189
PG 16	PG 21	6,5	10,0	17,5	29,7	12,0	IB-RB05P06P	189
	PG 29	7,0	12,0	17,5	40,0	16,0	IB-RB05P07P	189
	PG 29	7,0	14,0	24,0	39,0	16,0	IB-RB06P07P	105
PG 29	PG 36	8,0	17,5	32,0	50,0	19,5	IB-RB07P08P	70
PG 36	PG 42	9,0	19,0	38,0	57,0	22,0	IB-RB08P09P	24
PG 42	PG 48	10,0	19,5	49,2	64,0	23,0	IB-RB09P10P	24

Order Coding

Part Number	Material	-	Gasket (Washer)
Mandatory	Mandatory	-	Option
See table	BN Brass Nickel plated X Stainless steel	-	WN NBR WC CR (Chloroprene) WS Silicone

Example

IB-RB03M04M	BN	-	WC
-------------	----	---	----

Adaptors Metal

Adaptors for different threads

- For metal machines and housings.
- Adaptors for the transition of different thread types and sizes.

Technical Details

Material	Brass Nickel plated, Stainless Steel
Thread Type	<ul style="list-style-type: none"> • Metric EN 60423 • PG DIN 40430
Accessories	<ul style="list-style-type: none"> • Lock nuts • Gaskets (Washers)
Remarks	<ul style="list-style-type: none"> • We recommend the use of lock nuts and gaskets to ensure IP rating for rough surfaces or through holes. • Accessories must be ordered separately.

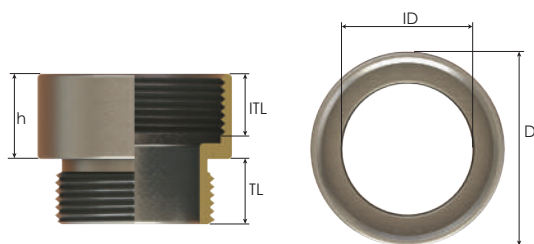

Thread Type **METRIC - PG** acc. to EN 60423 / DIN 40430

Outer Thread Size (Male)	Inner Thread Size (Female)	Outer Thread Length	Inner Thread Length	Inner Ø	Outer Ø	Height	Part Number	Minimum Order Quantity
		TL mm	ITL mm	ID mm	D mm	h mm		
M12x1,5	PG 9	6,0	7,0	8,0	17,0	9,0	IB-RB0SM02P	189
M16x1,5	PG 11	6,0	7,5	12,0	20,0	9,0	IB-RB01M03P	189
M20x1,5	PG 16	8,0	8,5	16,0	24,0	10,5	IB-RB02M05P	189
M25x1,5	PG 16	10,0	9,0	20,0	28,0	11,5	IB-RB03M05P	105
	PG 21	9,0	10,0	20,0	30,0	12,5	IB-RB03M06P	70
M32x1,5	PG 29	8,0	13,0	27,5	40,0	16,0	IB-RB04M07P	40
M40x1,5	PG 36	9,0	14,0	35,5	50,0	18,5	IB-RB05M08P	24
M50x1,5	PG 42	9,0	18,0	45,5	57,0	22,0	IB-RB06M09P	24
M63x1,5	PG 48	9,0	18,0	56,0	64,0	23,0	IB-RB07M10P	10

Order Coding			
Part Number	Material	-	Gasket (Washer)
Mandatory	Mandatory	-	Option
See table	BN Brass Nickel plated X Stainless steel	-	WN NBR WC CR (Chloroprene) WS Silicone
Example			
IB-RB03M05P	BN	-	WC



Adaptors for different threads

- For metal machines and housings.
- Adaptors for the transition of different thread types and sizes.

Technical Details

Material	Brass Nickel plated, Stainless Steel
Thread Type	<ul style="list-style-type: none"> • Metric EN 60423 • PG DIN 40430
Accessories	<ul style="list-style-type: none"> • Lock nuts • Gaskets (Washers)
Remarks	<ul style="list-style-type: none"> • We recommend the use of lock nuts and gaskets to ensure IP rating for rough surfaces or through holes. • Accessories must be ordered separately.

Short Type

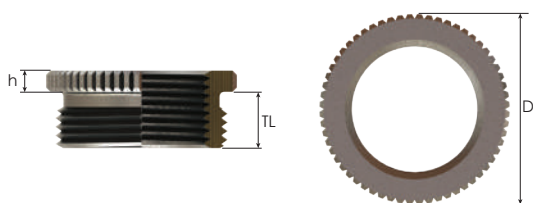

Long Type

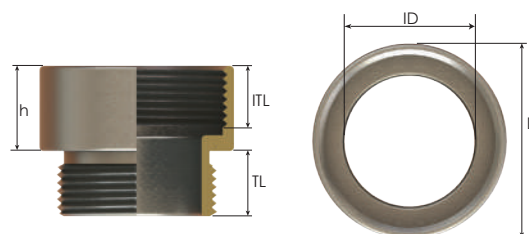

Thread Type METRIC - PG acc. to EN 60423 / DIN 40430

Outer Thread Size (Male)	Inner Thread Size (Female)	Outer Thread Length		Inner Thread Length	Inner Ø	Outer Ø	Height		Design Type	Part Number	Minimum Order Quantity
		TL	ITL				mm	mm			
PG 7	M12x1,5	5,0	7,0	8,0	14,0	10,0	long	IB-RB01P0SM	189		
PG 9	M16x1,5	6,0	8,0	11,5	18,0	11,0	long	IB-RB02P01M	189		
PG 11	M16x1,5	6,0	9,0	-	20,0	3,0	short	IB-RA03P01M	189		
	M20x1,5	6,0	8,5	14,5	22,0	11,5	long	IB-RB03P02M	189		
PG 13,5	M20x1,5	6,5	8,5	16,5	22,0	11,5	long	IB-RB04P02M	105		
PG 16	M20x1,5	6,0	9,0	-	24,0	3,0	short	IB-RA05P02M	105		
	M25x1,5	6,5	8,5	17,5	27,0	12,5	long	IB-RB05P03M	70		
PG 21	M20x1,5	7,0	10,0	-	30,0	3,0	short	IB-RA06P02M	70		
	M25x1,5	7,0	10,0	-	30,0	3,0	short	IB-RA06P03M	40		
	M32x1,5	7,0	12,0	24,0	34,0	16,0	long	IB-RB06P04M	40		
	M25x1,5	8,0	11,5	-	39,0	3,5	short	IB-RA07P03M	24		
PG 29	M32x1,5	8,0	11,5	-	39,0	3,5	short	IB-RA07P04M	10		
	M40x1,5	8,0	15,0	32,0	42,0	19,5	long	IB-RB07P05M	24		
	M50x1,5	8,0	16,0	32,0	54,0	19,5	long	IB-RB07P06M	24		
PG 36	M40x1,5	9,0	12,5	-	50,0	3,5	short	IB-RA08P05M	10		

Order Coding

Part Number	Material	-	Gasket (Washer)
Mandatory	Mandatory	-	Option
See table	BN Brass Nickel plated X Stainless steel	-	WN NBR WC CR (Chloroprene) WS Silicone

Example

IB-RB03M05P	BN	-	WC
-------------	----	---	----

Reducers Metal

Reducers for different thread sizes

- For metal machines and housings.
- Reducers for the transition of different thread types and sizes.

Technical Details

Material	Brass Nickel plated, Stainless Steel
Thread Type	<ul style="list-style-type: none"> • Metric EN 60423 • PG DIN 40430
Accessories	<ul style="list-style-type: none"> • Lock nuts • Gaskets (Washers)
Remarks	<ul style="list-style-type: none"> • We recommend the use of lock nuts and gaskets to ensure IP rating for rough surfaces or through holes. • Accessories must be ordered separately.

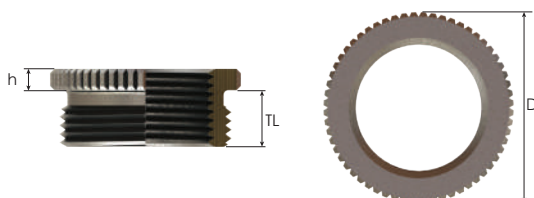

Thread Type METRIC - METRIC acc. to EN 60423

Outer Thread Size (Male)	Inner Thread Size (Female)	Outer Thread Length		Outer Ø		Height		Part Number	Minimum Order Quantity
		TL mm		D mm		h mm			
M16x1,5	M12x1,5	6,5		18,0		3,0		IB-RA01M0SM	189
M20x1,5	M12x1,5	6,5		22,0		3,0		IB-RA02M0SM	189
	M16x1,5	6,5		22,0		2,5		IB-RA02M01M	189
M25x1,5	M16x1,5	6,5		28,0		2,5		IB-RA03M01M	105
	M20x1,5	8,0		30,0		3,5		IB-RA03M02M	105
M32x1,5	M20x1,5	8,0		39,0		3,5		IB-RA04M02M	70
	M25x1,5	8,0		39,0		3,5		IB-RA04M03M	70
M40x1,5	M25x1,5	9,0		50,0		3,5		IB-RA05M03M	40
	M32x1,5	9,0		50,0		3,5		IB-RA05M04M	40
M50x1,5	M32x1,5	10,0		64,0		4,0		IB-RA06M04M	24
	M40x1,5	10,0		64,0		4,0		IB-RA06M05M	24
M63x1,5	M40x1,5	10,0		71,5		8,0		IB-RA07M05M	24
	M50x1,5	10,0		71,5		8,0		IB-RA07M06M	24
M72x1,5	M50x1,5	15,0		80,0		13,0		IB-RA08M06M	10
M75x1,5	M50x1,5	15,0		80,0		13,0		IB-RA09M06M	10

Order Coding

Part Number	Material	-	Gasket (Washer)
Mandatory	Mandatory	-	Option
See table	BN Brass Nickel plated X Stainless steel	-	WN NBR WC CR (Chloroprene) WS Silicone

Example

IB-RA07P04M	BN	-	WC
-------------	----	---	----

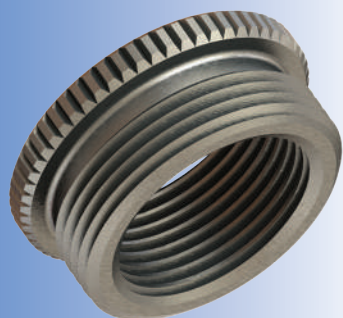

Reducers for different thread sizes

- For metal machines and housings.
- Reducers for the transition of different thread types and sizes.

Technical Details

Material	Brass Nickel plated, Stainless Steel
Thread Type	<ul style="list-style-type: none"> • Metric EN 60423 • PG DIN 40430
Accessories	<ul style="list-style-type: none"> • Lock nuts • Gaskets (Washers)
Remarks	<ul style="list-style-type: none"> • We recommend the use of lock nuts and gaskets to ensure IP rating for rough surfaces or through holes. • Accessories must be ordered separately.

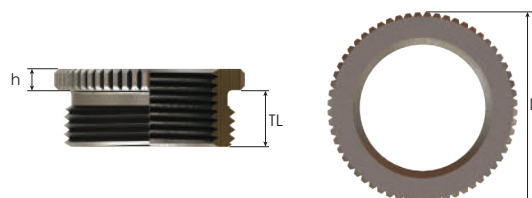

Thread Type PG - PG acc. to DIN 40430

Outer Thread Size (Male)	Inner Thread Size (Female)	Outer Thread Length		Outer Ø	Height		Part Number	Minimum Order Quantity
		TL	mm		h	mm		
PG 9	PG 7	6,0	17,0	2,5	IB-RA02P01P	189		
PG 11	PG 7	6,0	20,0	3,0	IB-RA03P01P	189		
	PG 9	6,0	20,0	3,0	IB-RA03P02P	189		
PG 13,5	PG 7	6,5	22,0	2,5	IB-RA04P01P	189		
	PG 9	6,5	22,0	2,5	IB-RA04P02P	189		
	PG 11	6,5	22,0	2,5	IB-RA04P03P	189		
PG 16	PG 7	6,5	24,0	3,0	IB-RA05P01P	105		
	PG 9	6,5	24,0	3,0	IB-RA05P02P	105		
	PG 11	6,0	24,0	3,0	IB-RA05P03P	105		
	PG 13,5	6,0	24,0	3,0	IB-RA05P04P	105		
PG 21	PG 11	7,0	30,0	3,0	IB-RA06P03P	70		
	PG 13,5	7,0	30,0	3,0	IB-RA06P04P	70		
	PG 16	7,0	30,0	3,0	IB-RA06P05P	70		
PG 29	PG 13,5	8,0	39,0	3,5	IB-RA07P04P	40		
	PG 16	8,0	39,0	3,5	IB-RA07P05P	40		
	PG 21	8,0	39,0	3,5	IB-RA07P06P	40		
PG 36	PG 21	9,0	50,0	3,5	IB-RA08P06P	24		
	PG 29	9,0	50,0	3,5	IB-RA08P07P	24		
PG 42	PG 29	10,0	57,0	4,0	IB-RA09P07P	24		
	PG 36	10,0	57,0	4,0	IB-RA09P08P	24		
PG 48	PG 36	10,0	64,0	4,0	IB-RA10P08P	24		
	PG 42	10,0	64,0	4,0	IB-RA10P09P	24		

Order Coding

Part Number	Material	-	Gasket (Washer)
Mandatory	Mandatory	-	Option
See table	BN Brass Nickel plated X Stainless steel	-	WN NBR WC CR (Chloroprene) WS Silicone

Example

IB-RA07P04M	BN	-	WC
-------------	----	---	----

Hexagonal Plugs, Metal

Technical Details		
Material	Body	Brass, Brass Nickel Plated, Stainless steel
	O-ring	NBR, Silicone
Ingress Protection Rating	IP 68 (5 bar, 30 min), according to EN 60 529	
Operating Temperature	O-Ring Material	
	NBR	Silicone
		-30 °C to +100 °C -60 °C to +140 °C
Thread Type	Metric, according to EN 60423 PG, according to DIN 40430	
Accessories	<ul style="list-style-type: none"> • Lock nuts • Gaskets (Washer) 	
Remarks	<ul style="list-style-type: none"> • Accessories must be ordered separately. • O-ring available in Metric and PG threads. 	

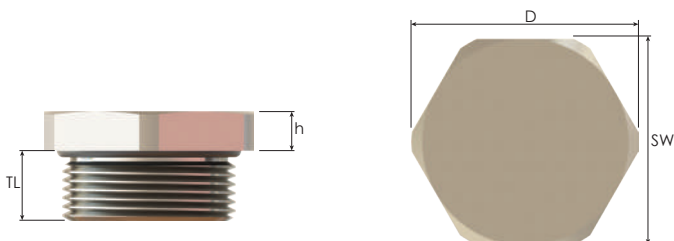

Thread Type METRIC acc. to EN 60423

Outer Thread Size (Male)	Outer Thread Length	Spanner Width	Outer Ø	Height	Part Number	Minimum Order Quantity
	TL mm			SW mm		
M12x1,5	6,0	15	16,5	3,5	ITSH-0SM	189
M16x1,5	7,0	19	21,0	3,5	ITSH-01M	189
M20x1,5	8,0	24	26,5	4,5	ITSH-02M	189
M25x1,5	8,0	30	33,0	4,5	ITSH-03M	70
M32x1,5	9,0	36	39,8	5,0	ITSH-04M	40
M40x1,5	9,0	45	50,0	5,0	ITSH-05M	24
M50x1,5	9,0	55	61,0	5,5	ITSH-06M	24
M63x1,5	10,0	70	78,0	5,5	ITSH-07M	10

Thread Type PG acc. to DIN 40430

Outer Thread Size (Male)	Outer Thread Length	Spanner Width	Outer Ø	Height	Part Number	Minimum Order Quantity
	TL mm			SW mm		
PG 7	6,0	15	16,5	3,5	ITSH-01P	189
PG 9	6,0	19	21,0	4,5	ITSH-02P	189
PG 11	6,0	22	24,0	4,5	ITSH-03P	189
PG 13,5	6,5	24	26,5	4,5	ITSH-04P	189
PG 16	6,5	27	30,0	4,5	ITSH-05P	105
PG 21	7,0	32	35,5	5,0	ITSH-06P	70
PG 29	8,0	41	45,5	5,0	ITSH-07P	40
PG 36	9,0	55	61,0	5,5	ITSH-08P	24
PG 42	10,0	60	66,5	5,5	ITSH-09P	24
PG 48	10,0	65	72,0	5,5	ITSH-10P	10

Thread Type NPT acc. to ANSI B1.20.1

Outer Thread Size (Male)	Outer Thread Length	Spanner Width	Outer Ø	Height	Part Number	Minimum Order Quantity
	TL mm			SW mm		
NPT 1/4"	12,0	16	17,7	4,0	ITSH-0SN	189
NPT 3/8"	12,0	20	22,0	4,0	ITSH-01N	189
NPT 1/2"	15,0	24	26,5	4,0	ITSH-02N	189
NPT 3/4"	15,0	28	31,0	4,0	ITSH-03N	105
NPT 1"	15,0	35	38,5	4,0	ITSH-04N	70
NPT 1 1/4"	17,0	45	50,0	4,0	ITSH-05N	40
NPT 1 1/2"	17,0	50	55,5	5,0	ITSH-06N	24
NPT 2"	17,0	65	72,0	5,0	ITSH-07N	24

Order Coding			
Part Number	Material	-	O-Ring
Mandatory	Mandatory	-	Option
See table	B Brass	-	N NBR
	BN Brass Nickel plated	-	S Silicone
	X Stainless steel	-	
Example			
ITSH-03P	X	-	WC

Round Plugs, Metal

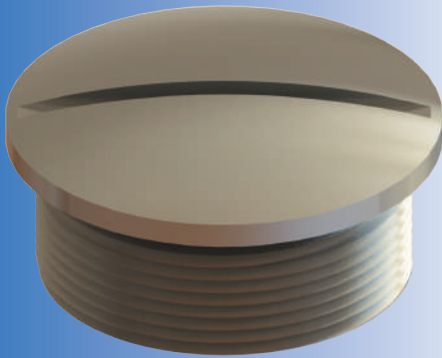

Technical Details		
Material	Body	Brass, Brass Nickel Plated, Stainless steel, Galvanised Steel
	O-Ring	NBR, Silicone
Ingress Protection Rating	IP 68 (5 bar, 30 min), according to EN 60 529	
Operating Temperature	O-Ring Material	
	NBR	Silicone
		-30 °C to +100 °C -60 °C to +140 °C
Thread Type	Metric, according to EN 60423 PG, according to DIN 40430	
Accessories	<ul style="list-style-type: none"> • Lock nuts • Gaskets (Washers) 	
Remarks	<ul style="list-style-type: none"> • Accessories must be ordered separately. • O-ring available in Metric and PG threads. 	

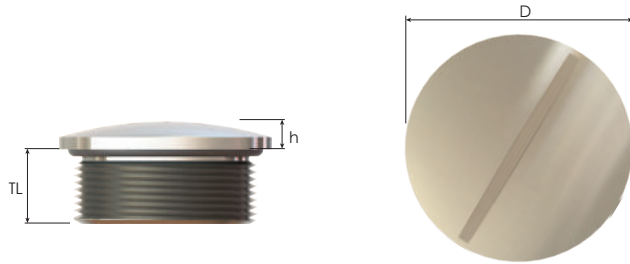

Thread Type **METRIC** acc. to EN 60423

Outer Thread Size (Male)	Outer Thread Length	Outer Ø	Height		Part Number	Minimum Order Quantity
	TL mm		D mm	h mm		
M12x1,5	6,0	15,0		2,5	ITSR-0SM	1000
M16x1,5	7,0	19,0		3,0	ITSR-01M	900
M20x1,5	8,0	23,0		3,0	ITSR-02M	500
M25x1,5	8,0	29,0		4,0	ITSR-03M	350
M32x1,5	9,0	36,0		4,0	ITSR-04M	200
M40x1,5	9,0	44,0		4,0	ITSR-05M	100
M50x1,5	9,0	54,0		5,0	ITSR-06M	50
M63x1,5	10,0	69,0		6,0	ITSR-07M	50

Thread Type **PG** acc. to DIN 40430

Outer Thread Size (Male)	Outer Thread Length	Outer Ø	Height		Part Number	Minimum Order Quantity
	TL mm		D mm	h mm		
PG 7	6,0	16,0		3,0	ITSR-01P	1000
PG 9	6,0	19,0		3,0	ITSR-02P	900
PG 11	6,0	22,0		3,0	ITSR-03P	600
PG 13,5	6,5	24,0		3,0	ITSR-04P	500
PG 16	6,5	26,0		3,0	ITSR-05P	400
PG 21	7,0	33,0		4,0	ITSR-06P	200
PG 29	8,0	42,0		4,0	ITSR-07P	100
PG 36	9,0	52,0		6,0	ITSR-08P	50
PG 42	10,0	59,0		6,0	ITSR-09P	50
PG 48	10,0	66,0		6,0	ITSR-10P	50

Order Coding			
Part Number	Material	-	O-Ring
Mandatory	Mandatory	-	Option
See table	B Brass BN Brass Nickel plated X Stainless steel	-	N NBR S Silicone
Example			
ITSR-01	X	-	N

Metal Cable Glands and Accessories Applications

Plastic & Metal Enclosures

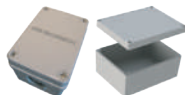

Sata Transmission



Remote Monitoring Systems



Electronic Balast



Control Boxes



Compressors



Low Voltage Fields



Main Low Voltage Switchboards



Transformers



Renewable Energy



Power Supply Control & Monitoring



Telecommunication Systems



Switching of Relay
Disconnectors
Contactors
Circuit Breakers



Metal Cable Glands and Accessories Applications

Cutch-Brake Units



Low & High Voltage Cabinets



Engine Connections



Machine Control Panels



Marine Asynchronous Motors



Incremental Encoders



Three-Phase Asynchronous Motors



Motor Applications



Electro Powered Cranes



Oil Pump Electrical Cabinets



Junction Boxes



Railway Systems



CABLE GLANDS & ACCESSORIES for GLOBAL HAZARDOUS APPLICATIONS

Electrical equipment in hazardous areas

In electrical engineering, a hazardous location is defined as a place where concentrations of flammable gases, vapors, or dusts occur. Electrical equipment that must be installed in such locations is especially designed and tested to ensure it does not initiate an explosion, due to arcing contacts or high surface temperature of equipment.

For example a household light switch may emit a small, harmless visible spark when switching; in an ordinary atmosphere this arc is of no concern, but if a flammable vapor is present, the arc might start an explosion. Electrical equipment intended for use in a chemical factory or refinery is designed either to contain any explosion within the device, or is designed not to produce sparks with sufficient energy to trigger an explosion.

Many strategies exist for safety in electrical installations. The simplest strategy is to minimize the amount of electrical equipment installed in a hazardous area, either by keeping the equipment out of the area altogether or by making the area less hazardous by process improvements or ventilation with clean air. Intrinsic safety, or non-incendive equipment and wiring methods, is a set of practices for apparatus designed with low power levels and low stored energy. Insufficient energy is available to produce an arc that can ignite the surrounding explosive mixture. Equipment enclosures can be pressurized with clean air or inert gas and designed with various controls to remove power or provide notification in case of supply or pressure loss of such gases. Arc-producing elements of the equipment can also be isolated from the surrounding atmosphere by encapsulation, immersion in oil, sand, etc. Heat producing elements such as motor winding, electrical heaters, including heat tracing and lighting fixtures are often designed to limit their maximum temperature below the autoignition temperature of the material involved. Both external and internal temperatures are taken into consideration.

As in most fields of electrical installation, different countries have approached the standardization and testing of equipment for hazardous areas in different ways. As world trade becomes more important in distribution of electrical products, international standards are slowly converging so that a wider range of acceptable techniques can be approved by national regulatory agencies.

Area classification is required by governmental bodies, for example by the U.S. Occupational Safety and Health Administration and compliance is enforced.

Documentation requirements are varied. Often an area classification plan-view is provided to identify equipment ratings and installation techniques to be used for each classified plant area. The plan may contain the list of chemicals with their group and temperature rating, and elevation details shaded to indicate Class, Division(Zone) and group combination. The area classification process would require the participation of operations, maintenance, safety, electrical and instrumentation professionals, the use of process diagrams and material flows, material safety data sheet and any pertinent documents, information and knowledge to determine the hazards and their extent and the countermeasures to be employed. Area classification documentations are reviewed and updated to reflect process changes.

History

Soon after the introduction of electric power into coal mines, it was discovered that lethal explosions could be initiated by electrical equipment such as lighting, signals, or motors. The hazard of fire damp or methane accumulation in mines was well known by the time electricity was introduced, along with the danger of suspended coal dust. At least two British mine explosions were attributed to an electric bell signal system. In this system, two bare wires were run along the length of a drift, and any miner desiring to signal the surface would momentarily touch the wires to each other or bridge the wires with a metal tool. The inductance of the signal bell coils, combined with breaking of contacts by exposed metal surfaces, resulted in sparks which could ignite methane, causing an explosion.

Gas divisions or zones

In an industrial plant such as a refinery or chemical process plant, handling of large quantities of flammable liquids and gases creates a risk of leaks. In some cases the gas, ignitable vapor or dust is present all the time or for long periods. Other areas would have a dangerous concentration of flammable substances only during process upsets, equipment deterioration between maintenance periods, or during an incident. Refineries and chemical plants are then divided into areas of risk of release of gas, vapor or dust known as divisions or zones. The process of determining the type and size of these hazardous areas is called area classification. Guidance on assessing the extent of the hazard is given in the NFPA 497 Standard, or API 500 and according to their adaptation by other areas gas zones is given in the current edition of IEC 60079.10. For hazardous dusts, the guiding standard is IEC 61421.10.

Typical gas hazards are from hydrocarbon compounds, but hydrogen and ammonia are common industrial gases that are flammable.

Non-Hazardous Area

An area such as a residence or office would be classed as Non Hazardous (safe area), where the only risk of a release of explosive or flammable gas would be such things as the propellant in an aerosol spray. The only explosive or flammable liquid would be paint and brush cleaner. These are classed as very low risk of causing an explosion and are more of a fire risk (although gas explosions in residential buildings do occur). Non hazardous areas on chemical and other plant are present where the hazardous gas is diluted to a concentration below 25% of its lower flammability limit (or lower explosive limit (LEL)).

Division 2 or Zone 2 area

This is a step up from the safe area. In this zone the gas, vapor or mist would only be present under abnormal conditions (most often leaks under abnormal conditions). As a general guide for Zone 2, unwanted substances should only be present under 10 hours/year or 0–0.1% of the time.

Division 1 or Zone 1 area

Gas, vapor or mist will be present or expected to be present for long periods of time under normal operating conditions. As a guide for Zone 1, this can be defined as 10–1000 hours/year or 0.1–10% of the time.

Zone 0 area

Gas or vapor is present all of the time. An example of this would be the vapor space above the liquid in the top of a tank or drum. The ANSI/NEC classification method consider this environment a Division 1 area. As a guide for Zone 0, this can be defined as over 1000 hours/year or >10% of the time.

Dust zones

Flammable gases when suspended in air can explode. An old system of area dust classification to a British standard used a system of letters to designate the zones. This has been replaced by a European numerical system, as set out in directive 1999/92/EU implemented in the UK as the Dangerous Substances and Explosives Atmospheres Regulations 2002

The boundaries and extent of these three dimensional zones should be decided by a competent person. There must be a site plan drawn up of the factory with the zones marked on. The zone definitions are:

- Zone 20
A place in which an explosive atmosphere in the form of a cloud of combustible dust in air is present continuously, or for long periods or frequently.
- Zone 21
A place in which an explosive atmosphere in the form of a cloud of combustible dust in air is likely to occur, occasionally, in normal operation.
- Zone 22
A place in which an explosive atmosphere in the form of a cloud of combustible dust in air is not likely to occur in normal operation but, if it does occur, will persist for a short period only.

Gas groups

Explosive gases, vapors and dusts have different chemical properties that affect the likelihood and severity of an explosion. Such properties include flame temperature, minimum ignition energy, upper and lower explosive limits, and molecular weight. Empirical testing is done to determine parameters such as the maximum experimental safe gap, minimum ignition current, explosion pressure and time to peak pressure, spontaneous ignition temperature, and maximum rate of pressure rise. Every substance has a differing combination of properties but it is found that they can be ranked into similar ranges, simplifying the selection of equipment for hazardous areas.

Flammability of combustible liquids are defined by their flash-point. The flash-point is the temperature at which the material will generate sufficient quantity of vapor to form an ignitable mixture. The flash point determines if an area needs to be classified. A material may have a relatively low autoignition temperature yet if its flash-point is above the ambient temperature, then the area may not need to be classified. Conversely if the same material is heated and handled above its flash-point, the area must be classified.

Each chemical gas or vapour used in industry is classified into a gas group.

ABBREVIATIONS	
OFF-SHORE	Marine application Harsh Environment
SWA	Steel wire armored
AWA	Aluminium wire armored
SWB	Steel wire braid
PWA	Pliable wire armored
STA	Steel tape armored



PRODUCTS FOR MINING APPLICATIONS

Mining Applications

Metal Products

Cable Glands for Armoured Cables

- | | |
|---|-----------|
| • Orion for Mining Applications | 132 - 135 |
| • Corona for Mining Applications | 136 - 139 |
| • Centaurus-A Barrier for Mining Applications | 140 - 141 |

Cable Glands for Non-armoured Cables

- | | |
|---|-----------|
| • Crater for Mining Applications | 144 - 147 |
| • Centaurus-N Barrier for Mining Applications | 148 - 149 |

PRODUCTS FOR HAZARDOUS APPLICATIONS

Gas / Dust Applications

Metal Products

Cable Glands for Armoured Cables

- | | |
|-----------------------|-----------|
| • Orion Universal | 152 - 155 |
| • Orion Offshore | 156 - 159 |
| • Orion | 160 - 163 |
| • Orion Lead Sheathed | 164 - 167 |
| • Corona Universal | 168 - 171 |
| • Corona Offshore | 172 - 175 |
| • Corona | 176 - 179 |
| • Centaurus-A Barrier | 180 - 181 |
| • E-Vela | 182 - 183 |

Cable Glands for Non-armoured Cables

- | | |
|-----------------------|-----------|
| • E-Octans | 186 - 189 |
| • E-Octans Flat | 190 - 191 |
| • Crater | 192 - 193 |
| • Centaurus-N Barrier | 194 - 195 |

Ventilation and Drain Products

- | | |
|----------------------------|-----------|
| • Hydra, Ventilation Plugs | 198 - 199 |
| • Virgo, Drain Plugs | 200 - 201 |

Fittings for Rigid Conduits with Non-armoured Cables

- | | |
|--|-----------|
| • E-Carina, Straight Conduit Fittings | 204 - 207 |
| • E-Carina Flat, Straight Conduit Fittings | 208 - 211 |
| • E-Cygnus, Swivel Conduit Fittings | 212 - 215 |
| • Phoenix, Multihole Swivel Conduit Fittings | 216 - 217 |

Fittings for Flexible Conduits with Non-armoured Cables

- | | |
|--------------|-----------|
| • E-Hydrus | 220 - 221 |
| • E-Scorpius | 222 - 223 |
| • E-Lupus | 224 - 225 |
| • E-Corvus | 226 - 227 |

Adaptors & Plugs

- | | |
|---------------------------|-----------|
| • Apus, Enlargers | 230 - 233 |
| • Grus, Reducers | 234 - 237 |
| • Aries, Couplings | 238 - 241 |
| • Pavo, Nipples | 242 - 245 |
| • Aquila Hexagonal, Plugs | 246 - 247 |
| • Aquila Round, Plugs | 248 - 249 |

Plastic Products

Cable Glands for Non-armoured Circular Cables

- | | |
|-----------|-----------|
| • Lyra | 252 - 253 |
| • Hi-Lyra | 254 - 257 |
| • Vega | 258 - 261 |

Cable Glands for Non-armoured Non-circular Cables

- | | |
|-------------|-----------|
| • Gemini | 262 - 263 |
| • Hi-Gemini | 264 - 265 |

Plugs

- | | |
|------------|-----------|
| • Draco | 268 - 269 |
| • Hi-Draco | 270 - 271 |

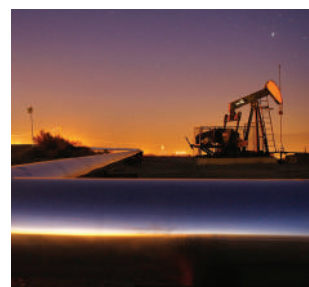

CABLE GLANDS for ARMOURED CABLES for Mining Applications



Orion for Mining Applications

132 - 135

Corona for Mining Applications

136 - 139

Centaurus-A Barrier for Mining Applications

140 - 141

Ex Glands / Group I / Mining



In mines where flammable minerals/materials are extracted, there can also be a risk of explosions because small particles of the extracted product can be blown into the air to form dust/air mixtures able to support rapid combustion.

Electrical equipment intended for mines where the atmosphere, in addition to firedamp, may contain significant proportions of other flammable gases (i.e. other than methane), shall be constructed and tested in accordance with the requirements relating to Group I and also to the subdivision of Group II corresponding to the other significant flammable gases.









Orion, Crater, Centaurus and Corona cable glands are tested according to IEC 60079 series and approved to be used in mining applications with M2, Mb protection level.

M 2 equipments may be used as it has a high level of protection and is suitable for the severe conditions in mining. In an explosive atmospheres, M 2 equipment needs to be capable of being disconnected or made safe.

Cable Glands for SWA and AWA Cables

ORION for Mining Application



Technical Details		
Material	Body, Cap	Brass, Brass Nickel Plated, Stainless Steel 316L
	Inner Part	Brass, Brass Nickel Plated, Stainless Steel 316L
	Seal	CR (Chloroprene) , Silicone
	O-ring	CR (Chloroprene) , Silicone
Ingress Protection Rating	IP 68 - 5 Bar, 30 min IP 66	
Operating Temperature	Seal Material	
	CR (Chloroprene)	Silicone
	Standard Group	-40°C to +80°C
LT Group	-40°C to +80°C	-60°C to +80°C
Equipment For	Mining potentially explosive atmospheres.	
Suitable for use in	Group I	Mining Group IMb Group I
Equipment Marking	Group I Ex I M2 Ex db I Mb Ex eb I Mb	
Marking Example *	BMD KBA.. CE 0722  I M2 Ex db I Mb Ex eb I Mb IP66/68 Ta -40°C to +80°C CESI 13 ATEX 033X IECEx CES 13.0013X	
Thread Type	<ul style="list-style-type: none"> • Metric (M) ISO Pitch 1,5 • NPT (N) ANSI ASME B1.20.1 • Other thread types also available upon request. 	
Cable Type	SWA - AWA	
Accessories	<ul style="list-style-type: none"> • Lock nuts • Gaskets (Washers) • Serrated Washers • Shrouds • Earth tags 	
Remarks	<ul style="list-style-type: none"> • O-ring available in Metric outer threads. • Accessories must be ordered separately. 	
Approvals	Certificate Number	Standards
	CESI 13 ATEX 033X	EN 60079-0:2012+A11:2013 EN 60079-1:2014 EN 60079-7:2015 EN 60079-31:2014
	IECEx CES 13.0013X	IEC 60079-0:2011 Edition:6 IEC 60079-1:2014 Edition:7 IEC 60079-31:2013 Edition:2 IEC 60079-7:2015-08 Edition:5
	20150612-E474828	UL 2225, CAN/CSA-C22.2 No. 60079-0:11 CAN/CSA C22.2 No. 60079-7:12 CAN/CSA-C22.2 No. 60079-31:12
	20170315-E199260	UL 514B UL50E
	№ TC RU C-TR.AA87.B.00941	ГОСТ 31610.0-2014 ГОСТ IEC 60079-1:2013 ГОСТ IEC 60079-31:2013
	DNV 12.0053 X	ABNT NBR IEC 60079-0:2013, ABNT NBR IEC 60079-1:2009, ABNT NBR IEC 60079-7:2008, ABNT NBR IEC 60079-31:2011
	E-14044	IEC/EN60079-0, IEC/EN60079-7, IEC/EN60079-31 IEC/EN60079-1, IEC/EN 62444
	MASC MS/18-0240X	SANS (IEC) 60079-0 : 2011 SANS (IEC) 60079-1 : 2014 SANS (IEC) 60079-7 : 2007 SANS (IEC) 60079-31 : 2014

-For more information see our webpage.

* The standard marking consists ATEX & IECEx only. Marking acc. to other standards on request.

Order Coding								
Part Number	Material	Seal	- Group	Gasket (Washer)	Serrated Washer	Lock Nut	Shroud	Earth Tag
Mandatory	Mandatory	Mandatory	- Mandatory	Option	Option	Option	Option	Option
See table	B Brass BN Brass Nickel plated X Stainless steel 316L	C Chloroprene S Silicone	- M Group I (Mining)	WC Chloroprene WS Silicone WF Fiber	WSR Serrated washer	L Lock nut	S Shroud	E Earth tag
Example								
KBA1N	BN	C	- M	-	WSR	L	S	-

ORION for Mining Application

Cable Glands for SWA and AWA Cables

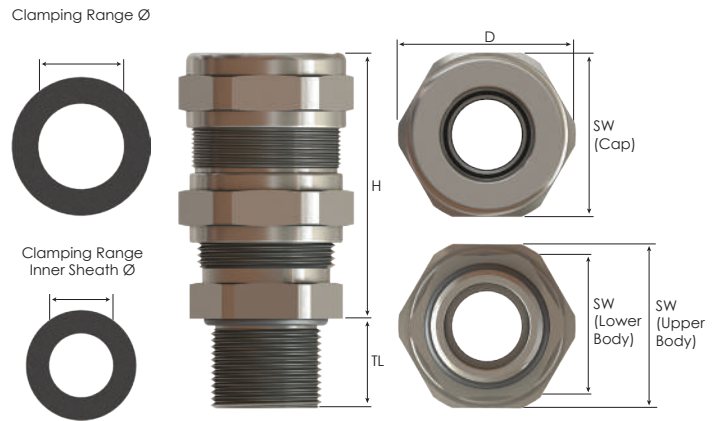

Thread Type **METRIC** acc. to ISO 965-3

Outer Thread Size (Male)	Clamping Range		Armour Wire Ø min-max mm	Outer Thread Length TL mm	Cap SW Cap mm	Spanner Width		Outer Ø D mm	max. Height H mm	Part Number
	Inner Sheath Ø min-max mm	Ø min-max mm				Upper Body SW Upper Body mm	Lower Body SW Lower Body mm			
M20x1,5	3,0 - 8,5	6,0 - 12,0	0,70 - 1,20	16,0	26	26	24	29,0	50,0	KBA1SM
	6,0 - 12,0	8,5 - 16,0	0,70 - 1,25	16,0	29	29	25	31,5	51,5	KBA1M
	8,5 - 14,5	12,0 - 20,0	0,90 - 1,30	16,0	32	30	28	35,0	54,0	KBA1LM
M25x1,5	3,0 - 8,5	6,0 - 12,0	0,70 - 1,20	18,0	26	26	29	31,5	50,0	KBA2XSM
	6,0 - 12,0	8,5 - 16,0	0,70 - 1,25	18,0	29	29	29	31,5	52,5	KBA2SM
	8,5 - 16,0	12,0 - 21,0	0,70 - 1,20	18,0	34	34	32	37,0	56,5	KBA2M
M32x1,5	6,0 - 12,0	8,5 - 16,0	0,70 - 1,25	18,0	40	40	36	39,8	52,5	KBA3XSM
	12,0 - 20,0	16,0 - 26,0	1,30 - 1,70	18,0	40	40	40	44,0	64,0	KBA3SM
	15,0 - 26,0	20,0 - 33,0	1,20 - 1,80	18,0	52	52	48	57,0	81,0	KBA3M
M40x1,5	12,0 - 20,0	16,0 - 26,0	1,30 - 1,70	18,0	40	40	45	50,0	64,0	KBA4XSM
	15,0 - 26,0	20,0 - 33,0	1,20 - 1,80	18,0	52	52	48	57,0	81,0	KBA4SM
	20,0 - 32,0	29,0 - 41,0	1,60 - 2,20	18,0	60	60	55	66,0	92,0	KBA4M
M50x1,5	15,0 - 26,0	20,0 - 33,0	1,20 - 1,80	18,0	52	52	54	60,0	81,0	KBA5XSM
	20,0 - 32,0	29,0 - 41,0	1,60 - 2,20	18,0	60	60	55	66,0	92,0	KBA5XMM
	22,0 - 35,0	33,0 - 48,0	2,00 - 2,80	18,0	75	70	60	83,0	100,0	KBA5SM
	27,0 - 41,0	36,0 - 52,0	1,80 - 2,80	18,0	74	70	70	81,8	104,5	KBA5M
M63x1,5	22,0 - 35,0	33,0 - 48,0	2,00 - 2,80	20,0	75	70	68	83,0	100,0	KBA6XSM
	27,0 - 41,0	36,0 - 52,0	1,80 - 2,80	20,0	74	70	70	81,8	104,5	KBA6XMM
	35,0 - 45,0	43,0 - 57,0	1,80 - 2,80	20,0	80	80	75	89,5	109,5	KBA6SM
	40,0 - 52,0	47,0 - 60,0	1,80 - 2,80	20,0	85	85	85	94,0	111,5	KBA6M
M75x1,5	45,0 - 56,0	54,0 - 70,0	1,30 - 2,50	20,0	100	95	90	110,5	128,5	KBA6LM
	35,0 - 45,0	43,0 - 57,0	1,80 - 2,80	20,0	80	80	85	94,0	109,5	KBA7XSM
	40,0 - 52,0	47,0 - 60,0	1,80 - 2,80	20,0	85	85	85	94,0	111,5	KBA7SM
M90x1,5	45,0 - 60,0	54,0 - 70,0	1,00 - 2,30	20,0	100	95	90	110,5	127,5	KBA7M
	40,0 - 52,0	47,0 - 60,0	1,80 - 2,80	20,0	85	85	100	110,5	111,5	KBA8XSM
M100x1,5	45,0 - 60,0	54,0 - 70,0	1,00 - 2,30	20,0	100	95	95	110,5	127,5	KBA8SM
	60,0 - 72,0	63,0 - 80,0	1,00 - 3,50	20,0	115	115	110	127,0	158,0	KBA8M

Thread Type **METRIC** acc. to ISO 965-3 (LT Type)

Outer Thread Size (Male)	Clamping Range		Armour Wire Ø min-max mm	Outer Thread Length TL mm	Cap SW Cap mm	Spanner Width		Outer Ø D mm	max. Height H mm	Part Number
	Inner Sheath Ø min-max mm	Ø min-max mm				Upper Body SW Upper Body mm	Lower Body SW Lower Body mm			
M90x2,0	70,0 - 82,0	78,0 - 90,0	1,5 - 4,4	20,0	120	120	115	134,0	159,5	KBA8MLT
M100x2,0	80,0 - 92,0	88,0 - 100,0	1,2 - 4,0	20,0	135	135	135	150,0	169,0	KBA9SMLT
M110x2,0	90,0 - 101,0	98,0 - 110,0	2,1 - 5,4	20,0	145	145	145	162,0	180,0	KBA10MLT
M130x2,0	100,0 - 115,0	109,0 - 123,0	2,0 - 5,4	24,0	160	160	160	176,0	202,0	KBA13MLT

Cable Glands for SWA and AWA Cables

ORION for Mining Applications



Technical Details			
Material	Body, Cap	Brass, Brass Nickel Plated, Stainless Steel 316L	
	Inner Part	Brass, Brass Nickel Plated, Stainless Steel 316L	
	Seal	CR (Chloroprene) , Silicone	
	O-ring	CR (Chloroprene) , Silicone	
Ingress Protection Rating	IP 68 - 5 Bar, 30 min IP 66		
Operating Temperature	Seal Material		
	CR (Chloroprene)	Silicone	
	Standard Group	-40°C to +80°C	-60°C to +80°C
LT Group	-40°C to +80°C		
Equipment For	Mining potentially explosive atmospheres.		
Suitable for use in	Group I	Mining Group IMb Group I	
Equipment Marking	Group I Ex I M2 Ex db I Mb Ex eb I Mb		
Marking Example *	BMD KBA.. CE 0722 I M2 Ex db I Mb Ex eb I Mb IP66/68 Ta -40°C to +80°C CESI 13 ATEX 033X IECEx CES 13.0013X		
Thread Type	<ul style="list-style-type: none"> • Metric (M) ISO Pitch 1,5 • NPT (N) ANSI ASME B1.20.1 • Other thread types also available upon request. 		
Cable Type	SWA - AWA		
Accessories	<ul style="list-style-type: none"> • Lock nuts • Gaskets (Washers) • Serrated Washers • Shrouds • Earth tags 		
	<ul style="list-style-type: none"> • O-ring available in Metric outer threads. • Accessories must be ordered separately. 		
	Remarks		
	Approvals	Certificate Number	Standards
		CESI 13 ATEX 033X	EN 60079-0:2012+A11:2013 EN 60079-1:2014 EN 60079-7:2015 EN 60079-31:2014
	IECEx CES 13.0013X	IEC 60079-0:2011 Edition:6 IEC 60079-1:2014 Edition:7 IEC 60079-31:2013 Edition:2 IEC 60079-7:2015-08 Edition:5	
	20150612-E474828	UL 2225, CAN/CSA-C22.2 No. 60079-0:11 CAN/CSA C22.2 No. 60079-7:12 CAN/CSA-C22.2 No. 60079-31:12	
	20170315-E199260	UL 514B UL50E	
	№ TC RU C-TR.AA87.B.00941	ГОСТ 31610.0-2014 ГОСТ IEC 60079-1:2013 ГОСТ IEC 60079-31:2013	
	DNV 12.0053 X	ABNT NBR IEC 60079-0:2013, ABNT NBR IEC 60079-1:2009, ABNT NBR IEC 60079-7:2008, ABNT NBR IEC 60079-31:2011	
	E-14044	IEC/EN60079-0, IEC/EN60079-7, IEC/EN60079-31 IEC/EN60079-1, IEC/EN 62444	
	MASC MS/18-0240X	SANS (IEC) 60079-0 : 2011 SANS (IEC) 60079-1 : 2014 SANS (IEC) 60079-7 : 2007 SANS (IEC) 60079-31 : 2014	

-For more information see our webpage.

* The standard marking consists ATEX & IECEx only. Marking acc. to other standards on request.

Order Coding

Part Number	Material	Seal	- Group	Gasket (Washer)	Serrated Washer	Lock Nut	Shroud	Earth Tag
Mandatory	Mandatory	Mandatory	- Mandatory	Option	Option	Option	Option	Option
See table	B Brass BN Brass Nickel plated X Stainless steel 316L	C Chloroprene S Silicone	- M Group I (Mining)	WC Chloroprene WS Silicone WF Fiber	WSR Serrated washer	L Lock nut	S Shroud	E Earth tag
Example								
KBA1N	BN	C	- M	-	WSR	L	S	-

ORION for Mining Applications

Cable Glands for SWA and AWA Cables

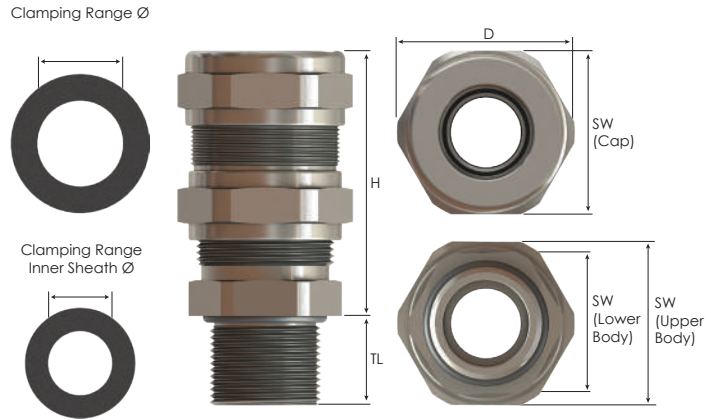





Thread Type NPT acc. to ANSI ASME B1.20.1										
Outer Thread Size (Male)	Clamping Range		Armour Wire Ø min-max mm	Outer Thread Length mm	Spanner Width			Outer Ø mm	max. Height mm	Part Number
	Inner Sheath Ø min-max mm	Ø min-max mm			Cap SW Cap mm	Upper Body SW Upper Body mm	Lower Body SW Lower Body mm			
NPT 1/2"	3,0 - 8,5	6,0 - 12,0	0,70 - 1,20	21,0	26	26	24	29,0	49,5	KBA1SN
	6,0 - 12,0	8,5 - 16,0	0,70 - 1,25	21,0	29	29	25	31,5	51,0	KBA1N
	8,5 - 14,5	12,0 - 20,0	0,90 - 1,30	21,0	32	30	28	35,0	54,0	KBA1LN
NPT 3/4"	3,0 - 8,5	6,0 - 12,0	0,70 - 1,20	21,0	26	26	29	31,5	50,0	KBA2XSN
	6,0 - 12,0	8,5 - 16,0	0,70 - 1,25	21,0	29	29	29	31,5	52,5	KBA2SN
	8,5 - 16,0	12,0 - 21,0	0,70 - 1,20	21,0	34	34	32	37,0	56,5	KBA2N
	12,0 - 20,0	16,0 - 26,0	1,30 - 1,70	21,0	40	40	36	44,0	62,5	KBA2LN
NPT 1"	6,0 - 12,0	8,5 - 16,0	0,70 - 1,25	26,0	29	29	36	39,8	52,5	KBA3XSN
	12,0 - 20,0	16,0 - 26,0	1,30 - 1,70	26,0	40	40	40	44,0	64,0	KBA3SN
	15,0 - 26,0	20,0 - 33,0	1,20 - 1,80	26,0	52	52	48	57,0	80,5	KBA3N
NPT 1 1/4"	12,0 - 20,0	16,0 - 26,0	1,30 - 1,70	28,0	40	40	45	50,0	64,0	KBA4XSN
	15,0 - 26,0	20,0 - 33,0	1,20 - 1,80	28,0	52	52	48	57,0	81,0	KBA4SN
	20,0 - 32,0	29,0 - 41,0	1,60 - 2,20	28,0	60	60	55	66,0	92,0	KBA4N
NPT 1 1/2"	15,0 - 26,0	20,0 - 33,0	1,20 - 1,80	28,0	52	52	54	60,0	81,0	KBA5XSN
	20,0 - 32,0	29,0 - 41,0	1,60 - 2,20	28,0	60	60	55	66,0	92,0	KBA5XMN
	22,0 - 35,0	33,0 - 48,0	2,00 - 2,80	28,0	75	70	60	83,0	100,0	KBA5SN
	27,0 - 41,0	36,0 - 52,0	1,80 - 2,80	28,0	74	70	70	81,8	104,5	KBA5N
NPT 2"	22,0 - 35,0	33,0 - 48,0	2,00 - 2,80	28,0	75	70	68	83,0	100,0	KBA6XSN
	27,0 - 41,0	36,0 - 52,0	1,80 - 2,80	28,0	74	70	70	81,8	104,5	KBA6XMN
	35,0 - 45,0	43,0 - 57,0	1,80 - 2,80	28,0	80	80	75	89,5	109,5	KBA6SN
	40,0 - 52,0	47,0 - 60,0	1,80 - 2,80	28,0	85	85	85	94,0	111,5	KBA6N
NPT 2 1/2"	45,0 - 52,0	54,0 - 70,0	1,30 - 2,50	28,0	100	95	90	110,5	128,5	KBA6LN
	35,0 - 45,0	43,0 - 57,0	1,80 - 2,80	41,0	80	80	80	89,5	109,0	KBA7XSN
	40,0 - 52,0	47,0 - 60,0	1,80 - 2,80	41,0	85	85	85	94,0	111,5	KBA7SN
NPT 3"	45,0 - 60,0	54,0 - 70,0	1,00 - 2,30	41,0	100	95	90	110,5	127,5	KBA7N
	40,0 - 52,0	47,0 - 60,0	1,80 - 2,80	43,0	85	85	95	105,0	111,5	KBA8XSN
	45,0 - 60,0	54,0 - 70,0	1,00 - 2,30	43,0	100	95	95	110,5	127,5	KBA8SN
60,0 - 72,0	63,0 - 80,0	1,00 - 3,50	43,0	115	115	110	127,0	158,0	KBA8N	

Thread Type NPT acc. to ANSI ASME B1.20.1 (LT Type)										
Outer Thread Size (Male)	Clamping Range		Armour Wire Ø min-max mm	Outer Thread Length TL mm	Spanner Width			Outer Ø D mm	max. Height H mm	Part Number
	Inner Sheath Ø min-max mm	Ø min-max mm			Cap SW Cap mm	Upper Body SW Upper Body mm	Lower Body SW Lower Body mm			
NPT 3 1/2"	70,0 - 82,0	78,0 - 90,0	1,5 - 4,4	45,0	120	120	115	134,0	159,5	KBA9MNLT
NPT 4"	80,0 - 92,0	88,0 - 100,0	1,2 - 4,0	46,0	135	135	135	150,0	169,0	KBA10SNLT
	90,0 - 101,0	98,0 - 110,0	2,1 - 5,4	46,0	145	145	145	162,0	180,0	KBA10NLT
NPT 5"	100,0 - 115,0	109,0 - 123,0	2,0 - 5,4	48,0	160	160	160	176,0	202,0	KBA11SNLT

Diaphragm Sealed Glands for SWA and AWA Cables

CORONA for Mining Applications



Technical Details		
Body, Cap	Brass, Brass Nickel Plated, Stainless Steel 316L	
Inner Part	Brass, Brass Nickel Plated, Stainless Steel 316L	
Material	Seal	Silicone
	O-ring	Silicone
	Lower Insert	PA 6 (Polyamide 6)
Ingress Protection Rating	IP 68 - 5 Bar, 30 min	
	IP 66	
Operating Temperature	Seal Material	Silicone
		-40°C to +80°C
Equipment For	Mining potentially explosive atmospheres.	
Suitable for use in	Mining Group IMb	
Equipment Marking	Group I Ex I M2 Ex db I Mb Ex eb I Mb	
Marking Example *	BMD KBC... CE 0722  I M2 Ex db I Mb Ex eb I Mb IP66/68 Ta -40°C to +80°C	
Thread Type	• Metric (M) ISO Pitch 1,5	
	• NPT (N) ANSI ASME B1.20.1	
	• Other thread types also available upon request.	
Cable Type	SWA - AWA	
Accessories	• Lock nuts	
	• Gaskets	
	• Serrated Washers	
	• Shrouds	
	• Earth tags	
Remarks	• O-ring available in Metric and NPT outer threads.	
	• Accessories must be ordered separately.	
Approvals	Certificate Number	Standards
  	CESI 13 ATEX 033X	EN 60079-0:2012+A11:2013 EN 60079-1:2014 EN 60079-7:2015 EN 60079-31:2014
	IECEx CES 17.0042X	IEC 60079-0:2011 Edition:6 IEC 60079-1:2014 Edition:7 IEC 60079-31:2013 Edition:2 IEC 60079-7:2015-08 Edition:5
	№ TC RU C-TR.AA87.B.00941	ГОСТ 31610.0-2014 ГОСТ IEC 60079-1:2013 ГОСТ IEC 60079-31:2013
-For more information see our webpage.		
* The standard marking consists ATEX & IECEx only. Marking acc. to other standards on request.		



Order Coding								
Part Number	Material	Seal	- Group	Gasket (Washer)	Serrated Washer	Lock Nut	Shroud	Earth Tag
Mandatory	Mandatory	Mandatory	- Mandatory	Option	Option	Option	Option	Option
See table	B Brass BN Brass Nickel plated X Stainless Steel 316L	S Silicone	- M Group I (Mining)	WS Silicone WF Fiber	WSR Serrated washer	L Lock nut	S Shroud	E Earth tag
Example								
KBAC4M	BN	S	- M	-	WSR	L	S	-

CORONA for Mining Applications

Diaphragm Sealed Glands for SWA and AWA Cables

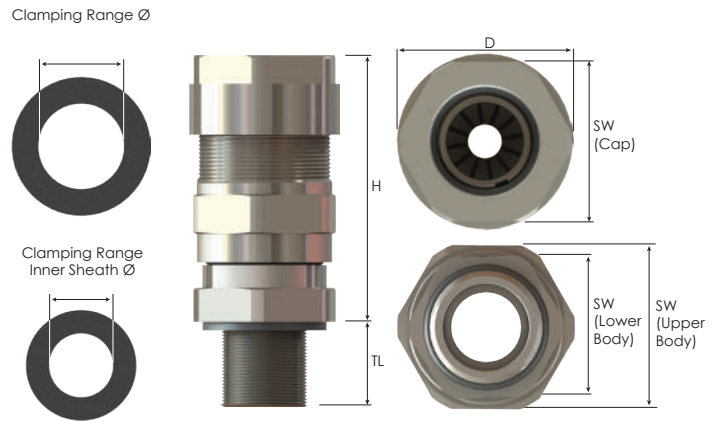





Thread Type METRIC acc. to ISO 965 - 3										
Outer Thread Size (Male)	Clamping Range		Armour Wire Ø min-max mm	Outer Thread Length TL mm	Spanner Width			Outer Ø D mm	max. Height H mm	Part Number
	Inner Sheath Ø min-max mm	Ø min-max mm			Cap SW Cap mm	Upper Body SW Upper Body mm	Lower Body SW Lower Body mm			
M16x1,5	6,0 - 11,0	9,0 - 16,0	0,8 - 1,25	15,0	24	24	24	27,5	45,0	KBC01M
	6,0 - 11,0	9,0 - 16,0			24	24	24			
M20x1,5	8,5 - 14,5	12,0 - 20,0	0,8 - 1,25	15,0	30	30	29	33,0	48,0	KBC1M
	8,5 - 14,5	12,0 - 20,0			30	30	36			
M25x1,5	12,0 - 20,0	16,0 - 26,0	1,25 - 1,6	15,0	36	36	36	40,0	54,0	KBC2M
	12,0 - 20,0	16,0 - 26,0			36	36	44			
M32x1,5	17,0 - 26,0	20,0 - 33,0	1,6 - 2,0	15,0	46	46	44	52,5	64,5	KBC3M
	17,0 - 26,0	20,0 - 33,0			46	46	55			
M40x1,5	23,0 - 32,0	29,0 - 41,0	1,6 - 2,0	15,0	55	55	65	74,0	77,7	KBC5M
	23,0 - 32,0	29,0 - 41,0			55	55	80			
M50x1,5	29,0 - 41,0	36,0 - 52,0	1,8 - 2,5	15,0	65	65	80	92,0	90,7	KBC6M
	29,0 - 41,0	36,0 - 52,0			65	65	95			
M63x1,5	44,0 - 56,0	50,0 - 65,0	1,8 - 2,5	15,0	80	80	95	107,5	103,7	KBC7M
	44,0 - 56,0	50,0 - 65,0			80	80	95			
M75x1,5	54,5 - 68,0	61,0 - 78,0	1,8 - 2,5	15,0	95	95	106	118,0	100,2	KBC8M
	54,5 - 68,0	61,0 - 78,0			95	95	115			
M80x1,5	67,0 - 73,0	75,0 - 89,0	2,0 - 3,5	15,0	106	106	115	133,0	100,0	KBC8M
	67,0 - 73,0	75,0 - 89,0			106	106	127			
M100x1,5	75,0 - 91,0	88,0 - 104,0	2,5 - 4,0	15,0	127	127	127	145,0	114,0	KBC9M

Diaphragm Sealed Glands for SWA and AWA Cables

CORONA for Mining Applications



Technical Details		
Body, Cap	Brass, Brass Nickel Plated, Stainless Steel 316L	
Inner Part	Brass, Brass Nickel Plated, Stainless Steel 316L	
Material	Seal	Silicone
	O-ring	Silicone
	Lower Insert	PA 6 (Polyamide 6)
Ingress Protection Rating	IP 68 - 5 Bar, 30 min IP 66	
Operating Temperature	Seal Material	Silicone
		-40°C to +80°C
Equipment For	Mining potentially explosive atmospheres.	
Suitable for use in	Mining Group IMb	
Equipment Marking	Group I Ex I M2 Ex db I Mb Ex eb I Mb	
Marking Example *	BMD KBC... CE 0722  I M2 Ex db I Mb Ex eb I Mb IP66/68 Ta -40°C to +80°C	
Thread Type	• Metric (M) ISO Pitch 1,5	
	• NPT (N) ANSI ASME B1.20.1	
	• Other thread types also available upon request.	
Cable Type	SWA - AWA	
Accessories	• Lock nuts	
	• Gaskets	
	• Serrated Washers	
	• Shrouds	
	• Earth tags	
Remarks	• O-ring available in Metric and NPT outer threads.	
	• Accessories must be ordered separately.	
Approvals	Certificate Number	Standards
	CESI 13 ATEX 033X	EN 60079-0:2012+A11:2013 EN 60079-1:2014 EN 60079-7:2015 EN 60079-31:2014
	IECEx CES 17.0042X	IEC 60079-0:2011 Edition:6 IEC 60079-1:2014 Edition:7 IEC 60079-31:2013 Edition:2 IEC 60079-7:2015-08 Edition:5
	№ TC RU C-TR.AA87.B.00941	ГОСТ 31610.0-2014 ГОСТ IEC 60079-1:2013 ГОСТ IEC 60079-31:2013
-For more information see our webpage.		
* The standard marking consists ATEX & IECEx only. Marking acc. to other standards on request.		



Order Coding								
Part Number	Material	Seal	- Group	Gasket (Washer)	Serrated Washer	Lock Nut	Shroud	Earth Tag
Mandatory	Mandatory	Mandatory	- Mandatory	Option	Option	Option	Option	Option
See table	B Brass BN Brass Nickel plated X Stainless Steel 316L	S Silicone	- M Group I (Mining)	WS Silicone	WSR Serrated washer	L Lock nut	S Shroud	E Earth tag
Example								
KBAC4M	BN	S	- M	-	WSR	L	S	-

CORONA for Mining Applications

Diaphragm Sealed Glands for SWA and AWA Cables

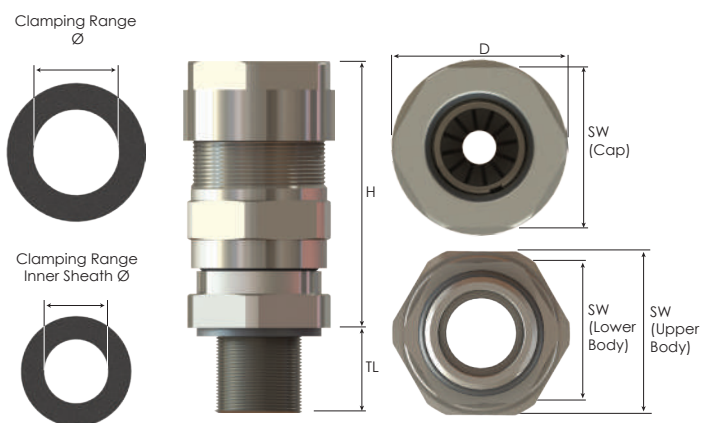





Thread Type **NPT** acc. to ANSI ASME B1.20.1

Outer Thread Size (Male)	Clamping Range		Armour Wire	Outer Thread Length	Cap	Spanner Width		Outer Ø	max. Height	Part Number
	Inner Sheath Ø min-max mm	Ø min-max mm	Ø min-max mm	TL mm	SW Cap mm	SW Upper Body mm	SW Lower Body mm			
NPT 3/8"	6,0 - 11,0	9,0 - 16,0	0,8 - 1,25	15,5	24	24	24	27,5	45,0	KBC01N
NPT 1/2"	6,0 - 11,0	9,0 - 16,0	0,8 - 1,25	20,1	24	24	24	27,5	45,0	KBC1SN
	8,5 - 14,5	12,0 - 20,0	0,8 - 1,25	20,1	30	30	29	33,0	48,0	KBC1N
NPT 3/4"	8,5 - 14,5	12,0 - 20,0	0,8 - 1,25	20,4	30	30	36	40,0	48,0	KBC2SN
	12,0 - 20,0	16,0 - 26,0	1,25 - 1,6	20,4	36	36	36	40,0	54,0	KBC2N
NPT 1"	12,0 - 20,0	16,0 - 26,0	1,25 - 1,6	25,5	36	36	44	52,5	54,0	KBC3SN
	17,0 - 26,0	20,0 - 33,0	1,6 - 2,0	25,5	44	46	44	52,5	64,5	KBC3N
NPT 1 1/4"	17,0 - 26,0	20,0 - 33,0	1,6 - 2,0	26,1	46	46	55	64,0	64,5	KBC4SN
	23,0 - 32,0	29,0 - 41,0	1,6 - 2,0	26,1	55	55	55	64,0	67,0	KBC4N
NPT 1 1/2"	23,0 - 32,0	29,0 - 41,0	1,6 - 2,0	26,5	55	55	65	74,0	67,0	KBC5SN
	29,0 - 39,0	36,0 - 52,0	1,8 - 2,5	26,5	65	65	65	74,0	77,7	KBC5N
NPT 2"	29,0 - 41,0	36,0 - 52,0	1,8 - 2,5	27,4	65	65	80	92,0	77,7	KBC6SN
	44,0 - 52,0	50,0 - 65,0	1,8 - 2,5	27,4	80	80	80	92,0	90,7	KBC6N
NPT 2 1/2"	44,0 - 56,0	50,0 - 65,0	1,8 - 2,5	40,4	80	80	95	107,5	90,7	KBC7SN
	54,5 - 63,0	61,0 - 78,0	1,8 - 2,5	40,4	95	95	95	107,5	103,7	KBC7N
NPT 3"	54,5 - 68,0	61,0 - 78,0	1,8 - 2,5	41,9	95	95	95	118,0	103,7	KBC80SN
	67,0 - 73,0	75,0 - 89,0	2,0 - 3,5	41,9	106	106	106	118,0	100,2	KBC80N
NPT 3 1/2"	67,0 - 77,0	75,0 - 89,0	2,0 - 3,5	43,2	115	115	115	133,0	100,0	KBC8N
NPT 4"	75,0 - 91,0	88,0 - 104,0	2,5 - 4,0	44,5	127	127	127	145,0	114,0	KBC9N

Barrier Cable Glands for All Types of Armoured Cables

CENTAURUS-A BARRIER for Mining Applications



Technical Details		
Material	Body, Cap	Brass, Brass Nickel Plated, Stainless Steel 316L
	Inner Parts	Brass, Brass Nickel Plated, Stainless Steel 316L
	Seal	Silicone
	O-Ring	Silicone
Ingress Protection Rating	IP 68 - 5 Bar, 30 min IP 66	
Operating Temperature	Seal Material	
	Silicone	-60°C to +60°C
Service Temperature	Seal Material	
	Silicone	-60°C to +100°C
Equipment For	Mining potentially explosive atmospheres	
Suitable for use in	Group I Mining Group IM	
Equipment Marking	Ex I M2 - Ex db IMb Ex eb IMb	
Marking Example*	BMD KBCTA.. CE 0722  I M2 Ex db I Mb Ex eb I Mb IP66/68 Ta -60°C to +60°C CESI 17 ATEX 007X IECEx CES 17.0029X	
Thread Type	<ul style="list-style-type: none"> • Metric (M) ISO Pitch 1.5 • NPT (N) ANSI ASME B1.20.1 • Other thread types also available upon request. 	
Cable Type	SWA - SWB - STA - Shielded	
Accessories	<ul style="list-style-type: none"> • Lock nuts • Gaskets (Washers) • Serrated Washers • Shrouds • Earth tags 	
Remarks	<ul style="list-style-type: none"> • O-ring available in Metric and NPT outer threads. • Accessories must be ordered separately. 	
Approvals	Certificate Number	Standards
	CESI 17 ATEX 0007X	EN 60079-0:2012+A11:2013 EN 60079-1:2014 EN 60079-7:2015 EN 60079-31:2014
	IECEx CES 17.0029X	IEC 60079-0:2011 Edition:6 IEC 60079-1:2014 Edition:7 IEC 60079-31:2013 Edition:2 IEC 60079-7:2015-08 Edition:5
	№ TC RU C-TR.AA87.B.00941	ГОСТ 31610.0-2014 ГОСТ IEC 60079-1:2013 ГОСТ IEC 60079-31:2013
-For more information see our webpage.		
* The standard marking consists ATEX & IECEx only. Marking acc. to other standards on request.		

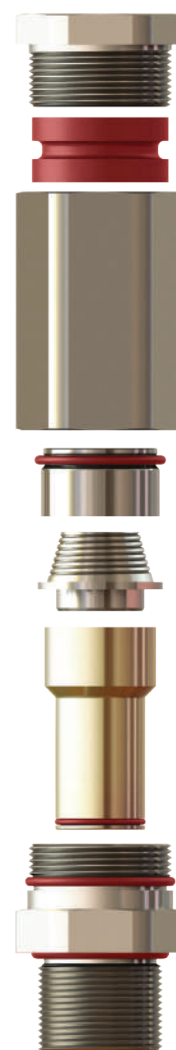

Order Coding								
Part Number	Material	Seal	- Group	Gasket (Washer)	Serrated Washer	Lock Nut	Shroud	Earth Tag
Mandatory	Mandatory	Mandatory	- Mandatory	Option	Option	Option	Option	Option
See table	B Brass BN Brass Nickel plated X Stainless steel 316L	S Silicone	- M Group I (Mining)	WS Silicone	WSR Serrated washer	L Lock nut	S Shroud	E Earth tag
Example								
KBCTA3N	BN	C	- M	-	WSR	L	S	-

CENTAURUS-A BARRIER for Mining Applications

Barrier Cable Glands for All Types of Armoured Cables

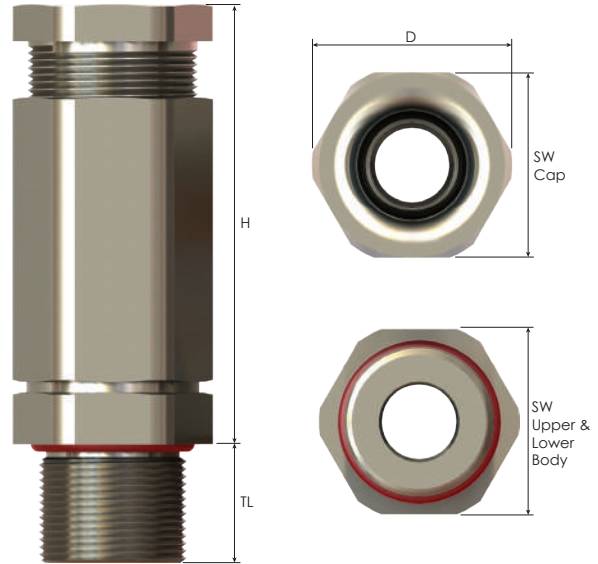

Mining Applications

Thread Type METRIC acc. to ISO 965-3

Outer Thread Size (Male)	Clamping Range Ø min-max mm	Over Conductors max Ø mm	Armour Wire max Ø mm	Outer Thread Length TL mm	Cap		Spanner Width		Outer Ø D mm	max. Height H mm	Part Number	Need Barrier Compound Material Per Pc. (g)
					SW Cap mm	SW Upper Body mm	Lower Body	SW Lower Body mm				
M20x1,5	6,0 - 13,0	9,5	1,3	16,0	25	25	25	25	27,0	63,5	KBCTA1SM	7
	8,0 - 15,0	9,5	1,3	16,0	25	25	25	25	27,0	63,5	KBCTA1M	7
	13,5 - 21,0	12,0	1,3	16,0	30	30	30	30	33,0	65,0	KBCTA1LM	6
M25x1,5	8,0 - 15,0	9,5	1,3	16,0	25	25	30	30	33,0	63,5	KBCTA2SM	7
	13,5 - 21,0	12,0	1,3	16,0	30	30	30	30	33,0	65,0	KBCTA2M	6
	18,0 - 27,0	15,0	1,6	16,0	40	40	40	40	44,5	72,5	KBCTA2LM	14
M32x1,5	18,0 - 27,0	15,0	1,6	16,0	40	40	40	40	44,5	72,5	KBCTA3M	14
	23,0 - 33,0	21,5	1,6	16,0	43	43	43	43	47,0	74,5	KBCTA3LM	26
M40x1,5	23,0 - 33,0	21,5	1,6	16,0	43	43	45	45	50,0	74,5	KBCTA4SM	26
	29,0 - 40,0	29,0	2,0	16,0	50	50	50	50	55,5	82,5	KBCTA4M	50
M50x1,5	29,0 - 40,0	29,0	2,0	16,0	50	50	55	55	61,0	82,5	KBCTA5SM	50
	35,0 - 48,0	37,0	2,5	16,0	58	58	58	58	64,0	90,5	KBCTA5M	82
M63x1,5	35,0 - 48,0	37,0	2,5	20,0	58	58	68	68	75,0	90,5	KBCTA6SM	82
	42,0 - 56,0	46,0	2,5	20,0	75	75	75	75	83,0	120,0	KBCTA6M	180
M75x1,5	42,0 - 56,0	46,0	2,5	20,0	75	75	80	80	89,0	120,0	KBCTA7SM	180
	54,0 - 70,0	58,0	3,2	20,0	100	100	100	100	110,5	126,0	KBCTA7M	290
M90x1,5	54,0 - 70,0	58,0	3,2	20,0	100	100	100	100	110,5	126,0	KBCTA8M	290

*Barrier compound is served as 50 g standard.

Thread Type NPT acc. to ANSI ASME B1.20.1

Outer Thread Size (Male)	Clamping Range Ø min-max mm	Over Conductors max Ø mm	Armour Wire max. Ø mm	Outer Thread Length TL mm	Cap		Spanner Width		Outer Ø D mm	max. Height H mm	Part Number	Barrier Compound Material Per Pc. (g)
					SW Cap mm	SW Upper Body mm	Lower Body	SW Lower Body mm				
NPT 1/2	6,0 - 13,0	9,5	1,3	21,0	25	25	25	25	27,0	63,5	KBCTA1SN	7
	8,0 - 15,0	9,5	1,3	21,0	25	25	25	25	27,0	63,5	KBCTA1N	7
	13,5 - 21,0	12,0	1,3	21,0	30	30	30	30	33,0	65,0	KBCTA1LN	6
NPT 3/4"	8,0 - 15,0	9,5	1,3	21,0	25	25	30	30	33,0	63,5	KBCTA2SN	7
	13,5 - 21,0	12,0	1,3	21,0	30	30	30	30	33,0	65,0	KBCTA2N	6
	18,0 - 27,0	15,0	1,6	21,0	40	40	40	40	44,5	72,5	KBCTA2LN	14
NPT 1"	18,0 - 27,0	15,0	1,6	26,0	40	40	40	40	44,5	72,5	KBCTA3N	14
	23,0 - 33,0	21,5	1,6	26,0	43	43	43	43	47,0	74,5	KBCTA3LN	26
NPT 1 1/4"	23,0 - 33,0	21,5	1,6	28,0	43	43	45	45	50,0	74,5	KBCTA4SN	26
	29,0 - 40,0	29,0	2,0	28,0	50	50	50	50	55,5	82,5	KBCTA4N	50
NPT 1 1/2"	29,0 - 40,0	29,0	2,0	28,0	50	50	55	55	61,0	82,5	KBCTA5N	50
NPT 2"	35,0 - 48,0	37,0	2,5	28,0	58	58	65	65	72,0	90,5	KBCTA6N	82
NPT 2 1/2"	42,0 - 56,0	46,0	2,5	41,0	75	75	80	80	89,0	120,0	KBCTA7N	180
NPT 3"	54,0 - 70,0	58,0	3,2	43,0	100	100	100	100	110,5	126,0	KBCTA8N	290

*Barrier compound is served as 50 g standard.

CABLE GLANDS for NON-ARMOURED CABLES for Mining Applications



Crater for Mining Applications
Centaurus-N Barrier for Mining Applications

144 - 147
148 - 149

Ex Glands / Group I / Mining



GROUP I (Mining)

In mines where flammable minerals/materials are extracted, there can also be a risk of explosions because small particles of the extracted product can be blown into the air to form dust/air mixtures able to support rapid combustion.

Electrical equipment intended for mines where the atmosphere, in addition to firedamp, may contain significant proportions of other flammable gases (i.e. other than methane), shall be constructed and tested in accordance with the requirements relating to Group I and also to the subdivision of Group II corresponding to the other significant flammable gases.







Orion, Crater, Centaurus and Corona cable glands are tested according to IEC 60079 series and approved to be used in mining applications with M2, Mb protection level.

M 2 equipments may be used as it has a high level of protection and is suitable for the severe conditions in mining. In an explosive atmospheres, M 2 equipment needs to be capable of being disconnected or made safe.

Cable Glands for Non-Armoured Cables

CRATER for Mining Applications



Technical Details		
Material	Body, Cap	Brass, Brass Nickel Plated, Stainless Steel 316L
	Inner Parts	Brass, Brass Nickel Plated, Stainless Steel 316L
	Seal	CR (Chloroprene), Silicone
	O-ring	CR (Chloroprene), Silicone
Ingress Protection Rating	IP 68 - 5 Bar, 30 min IP 66	
Operating Temperature	Seal Material	
	Chloroprene	Silicone
Group I	-40°C to +80°C	-60°C to +100°C
Equipment For	Mining potentially explosive atmospheres.	
Suitable for use in	Group I Mining Group IMb	
Equipment Marking	Group I Ex I M2 Ex db I Mb Ex eb I Mb	
Marking Example*	BMD MKBU.. CE 0722  I M2 Ex db I Mb Ex eb I Mb IP66/68 Ta -40°C to +80°C CESI 13 ATEX 033X IECEx CES 13.0013X	
Thread Type	<ul style="list-style-type: none"> • Metric (M) ISO Pitch 1.5 • NPT (N) ANSI ASME B1.20.1 • Other thread types also available upon request. 	
Cable Type	Non-armoured	
Accessories	<ul style="list-style-type: none"> • Lock nuts • Gaskets (Washers) • Serrated Washers • Shrouds • Earth tags 	
Remarks	<ul style="list-style-type: none"> • O-ring available in Metric outer threads. • Accessories must be ordered separately. 	
Approvals	Certificate Number	Standards
	CESI 13 ATEX 033X	EN 60079-0:2012+A11:2013 EN 60079-1:2014 EN 60079-7:2015 EN 60079-31:2014
	IECEx CES 13.0013X	IEC 60079-0:2011 Edition:6 IEC 60079-1:2014 Edition:7 IEC 60079-31:2013 Edition:2 IEC 60079-7:2015-08 Edition:5
	№ TC RU C-TR.AA87.B.00941	ГОСТ 31610.0-2014 ГОСТ IEC 60079-1:2013 ГОСТ IEC 60079-31:2013
	DNV 12.0053 X	ABNT NBR IEC 60079-0:2013, ABNT NBR IEC 60079-1:2009, ABNT NBR IEC 60079-7:2008, ABNT NBR IEC 60079-31:2011
	E-14044	IEC/EN60079-0, IEC/EN60079-7, IEC/EN60079-31 IEC/EN60079-1, IEC/EN 62444
	MASC MS/18-0240X	SANS (IEC) 60079-0 : 2014 SANS (IEC) 60079-1 : 2009 SANS (IEC) 60079-7 : 2007 SANS (IEC) 60079-31 : 2014

-For more information see our webpage.

* The standard marking consists ATEX & IECEx only. Marking acc. to other standards on request.

Order Coding						
Part Number	Material	Seal	-	Gasket (Washer)	Serrated Washer	Lock Nut
Mandatory	Mandatory	Mandatory	-	Option	Option	Option
See table	B Brass BN Brass Nickel plated X Stainless steel 316L	C Chloroprene S Silicone	-	WC Chloroprene WS Silicone WF Fiber	WSR Serrated washer	L Lock nut
						E Earth tag
Example						
MKBUSN1	BN	S	-	WC	WSR	L E

CRATER for Mining Applications

Cable Gland for Non-Armoured Cable

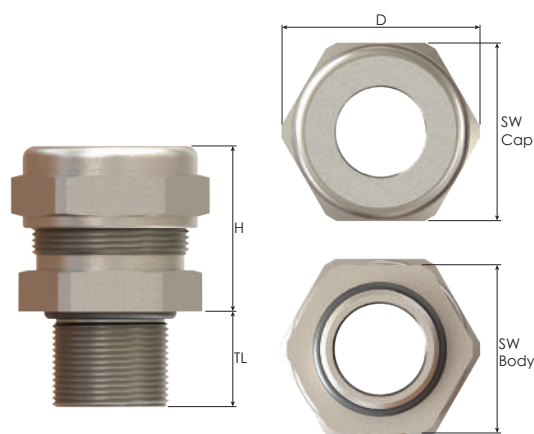







Thread Type METRIC acc. to ISO 965 - 3							
Outer Thread Size (Male)	Clamping Range	Outer Thread Length	Spanner Width		Outer Ø	max. Height	Part Number
			Cap	Body			
	Ø min - max mm	TL mm	SW Cap mm	SW Body mm	D mm	H mm	
M16x1,5	3,0 - 8,5	16,0	26	22	29,0	27,0	MKBU01M2
	6,0 - 9,0	16,0	29	27	31,5	31,5	MKBU01LM1
	9,0 - 12,0	16,0	29	27	31,5	31,5	MKBU01LM2
M20x1,5	6,0 - 9,0	16,0	29	27	31,5	31,5	MKBU1M1
	9,0 - 12,0	16,0	29	27	31,5	31,5	MKBU1M2
	8,5 - 11,5	16,0	30	28	33,5	34,0	MKBU1LM1
	11,5 - 14,5	16,0	30	28	33,5	34,0	MKBU1LM2
M25x1,5	6,0 - 9,0	18,0	29	29	31,5	31,0	MKBU2SM1
	9,0 - 12,0	18,0	29	29	31,5	31,0	MKBU2SM2
	8,5 - 12,5	18,0	34	32	37,0	35,5	MKBU2M1
	12,5 - 16,0	18,0	34	32	37,0	35,5	MKBU2M2
	12,0 - 16,0	18,0	40	36	44,5	35,5	MKBU2LM1
	16,0 - 20,0	18,0	40	36	44,5	35,5	MKBU2LM2
M32x1,5	12,0 - 16,0	18,0	40	40	44,5	36,5	MKBU3SM1
	16,0 - 20,0	18,0	40	40	44,5	36,5	MKBU3SM2
	15,0 - 20,0	18,0	52	48	57,0	43,0	MKBU3M1
	20,0 - 26,0	18,0	52	48	57,0	43,0	MKBU3M2
M40x1,5	15,0 - 20,0	18,0	52	48	57,0	43,0	MKBU4SM1
	20,0 - 26,0	18,0	52	48	57,0	43,0	MKBU4SM2
	20,0 - 26,0	18,0	60	55	66,0	52,0	MKBU4M1
	26,0 - 32,0	18,0	60	55	66,0	52,0	MKBU4M2
M50x1,5	22,0 - 28,0	18,0	70	60	77,0	52,0	MKBU5SM1
	28,0 - 35,0	18,0	70	60	77,0	52,0	MKBU5SM2
	27,0 - 34,0	18,0	70	70	77,0	56,0	MKBU5M1
	34,0 - 41,0	18,0	70	70	77,0	56,0	MKBU5M2
M63x1,5	35,0 - 40,0	20,0	80	75	89,5	63,5	MKBU6SM1
	40,0 - 45,0	20,0	80	75	89,5	63,5	MKBU6SM2
	40,0 - 46,0	20,0	85	85	94,0	64,0	MKBU6M1
	46,0 - 52,0	20,0	85	85	94,0	64,0	MKBU6M2
M75x1,5	40,0 - 46,0	20,0	85	85	94,0	64,0	MKBU7SM1
	46,0 - 52,0	20,0	85	85	94,0	64,0	MKBU7SM2
	45,0 - 52,0	20,0	95	90	105,0	79,0	MKBU7M1
	52,0 - 60,0	20,0	95	90	105,0	79,0	MKBU7M2
M90x1,5	45,0 - 52,0	20,0	95	95	105,0	79,0	MKBU8SM1
	52,0 - 60,0	20,0	95	95	105,0	79,0	MKBU8SM2
	60,0 - 66,0	20,0	115	110	127,0	86,0	MKBU8M1
	66,0 - 72,0	20,0	115	110	127,0	86,0	MKBU8M2

Cable Glands for Non-Armoured Cables

CRATER for Mining Applications



Technical Details		
Material	Body, Cap	Brass, Brass Nickel Plated, Stainless Steel 316L
	Inner Parts	Brass, Brass Nickel Plated, Stainless Steel 316L
	Seal	CR (Chloroprene), Silicone
	O-ring	CR (Chloroprene), Silicone
Ingress Protection Rating	IP 68 - 5 Bar, 30 min IP 66	
Operating Temperature	Seal Material	
	Chloroprene	Silicone
Group I	-40°C to +80°C	-60°C to +100°C
Equipment For	Mining potentially explosive atmospheres.	
Suitable for use in	Group I Mining Group I Mb	
Equipment Marking	Group I Ex I M2 Ex db I Mb Ex eb I Mb	
Marking Example*	BMD MKBU.. CE 0722  I M2 Ex db I Mb Ex eb I Mb IP66/68 Ta -40°C to +80°C CESI 13 ATEX 033X IECEx CES 13.0013X	
Thread Type	<ul style="list-style-type: none"> • Metric (M) ISO Pitch 1.5 • NPT (N) ANSI ASME B1.20.1 • Other thread types also available upon request. 	
Cable Type	Non-armoured	
Accessories	<ul style="list-style-type: none"> • Lock nuts • Gaskets (Washers) • Serrated Washers • Shrouds • Earth tags 	
Remarks	<ul style="list-style-type: none"> • O-ring available in Metric outer threads. • Accessories must be ordered separately. 	
Approvals	Certificate Number	Standards
	CESI 13 ATEX 033X	EN 60079-0:2012+A11:2013 EN 60079-1:2014 EN 60079-7:2015 EN 60079-31:2014
	IECEx CES 13.0013X	IEC 60079-0:2011 Edition:6 IEC 60079-1:2014 Edition:7 IEC 60079-31:2013 Edition:2 IEC 60079-7:2015-08 Edition:5
	№ TC RU C-TR.AA87.B.00941	ГОСТ 31610.0-2014 ГОСТ IEC 60079-1:2013 ГОСТ IEC 60079-31:2013
	DNV 12.0053 X	ABNT NBR IEC 60079-0:2013, ABNT NBR IEC 60079-1:2009, ABNT NBR IEC 60079-7:2008, ABNT NBR IEC 60079-31:2011
	E-14044	IEC/EN60079-0, IEC/EN60079-7, IEC/EN60079-31 IEC/EN60079-1, IEC/EN 62444
	MASC MS/18-0240X	SANS (IEC) 60079-0 : 2014 SANS (IEC) 60079-1 : 2009 SANS (IEC) 60079-7 : 2007 SANS (IEC) 60079-31 : 2014

-For more information see our webpage.
* The standard marking consists ATEX & IECEx only. Marking acc. to other standards on request.

Order Coding							
Part Number	Material	Seal	-	Gasket (Washer)	Serrated Washer	Lock Nut	Earth Tag
Mandatory	Mandatory	Mandatory	-	Option	Option	Option	Option
See table	B Brass BN Brass Nickel plated X Stainless steel 316L	C Chloroprene S Silicone	-	WC Chloroprene WS Silicone WF Fiber	WSR Serrated washer	L Lock nut	E Earth tag
Example							
MKBU5N1	BN	S	-	WC	WSR	L	E

CRATER for Mining Applications

Cable Gland for Non-Armoured Cable

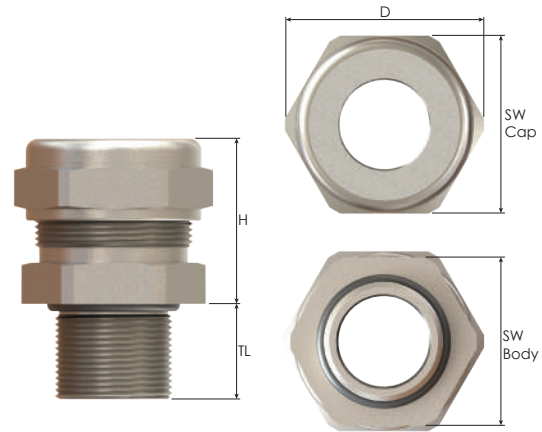





Thread Type **NPT** acc. to ANSI ASME B1.20.1

Outer Thread Size (Male)	Clamping Range Ø min - max mm	Outer Thread Length TL mm	Spanner Width		Outer Ø D mm	max. Height H mm	Part Number
			Cap SW Cap mm	Body SW Body mm			
NPT 3/8"	3,0 - 8,5	16,0	26	22	29,0	27,0	MKBU01N2
	6,0 - 9,0	16,0	29	27	31,5	31,5	MKBU01LN1
	9,0 - 12,0	16,0	29	27	31,5	31,5	MKBU01LN2
NPT 1/2"	6,0 - 9,0	21,0	29	27	31,5	31,5	MKBU1N1
	9,0 - 12,0	21,0	29	27	31,5	31,5	MKBU1N2
	8,5 - 11,5	21,0	30	28	33,5	34,0	MKBU1LN1
NPT 3/4"	11,5 - 14,5	21,0	30	28	33,5	34,0	MKBU1LN2
	6,0 - 9,0	21,0	29	29	31,5	31,0	MKBU2SN1
	9,0 - 12,0	21,0	29	29	31,5	31,0	MKBU2SN2
NPT 1"	8,5 - 12,5	21,0	34	32	37,0	35,5	MKBU2N1
	12,5 - 16,0	21,0	34	32	37,0	35,5	MKBU2N2
	12,0 - 16,0	21,0	40	36	44,5	35,0	MKBU2LN1
NPT 1 1/4"	16,0 - 20,0	21,0	40	36	44,5	35,0	MKBU2LN2
	12,0 - 16,0	26,0	40	40	44,5	36,5	MKBU3SN1
	16,0 - 20,0	26,0	40	40	44,5	36,5	MKBU3SN2
NPT 1 1/2"	15,0 - 20,0	26,0	52	48	57,0	42,5	MKBU3N1
	20,0 - 26,0	26,0	52	48	57,0	42,5	MKBU3N2
	15,0 - 20,0	28,0	52	48	57,0	44,5	MKBU4SN1
NPT 2"	20,0 - 26,0	28,0	52	48	57,0	44,5	MKBU4SN2
	20,0 - 26,0	28,0	60	55	66,0	52,0	MKBU4N1
	26,0 - 32,0	28,0	60	55	66,0	52,0	MKBU4N2
NPT 2 1/2"	22,0 - 28,0	28,0	70	60	77,0	52,0	MKBU5SN1
	28,0 - 35,0	28,0	70	60	77,0	52,0	MKBU5SN2
	27,0 - 34,0	28,0	70	70	77,0	56,0	MKBU5N1
NPT 3"	34,0 - 41,0	28,0	70	70	77,0	56,0	MKBU5N2
	35,0 - 40,0	28,0	80	75	89,5	63,0	MKBU6SN1
	40,0 - 45,0	28,0	80	75	89,5	63,0	MKBU6SN2
NPT 3 1/2"	40,0 - 46,0	28,0	85	85	94,0	64,0	MKBU6N1
	46,0 - 52,0	28,0	85	85	94,0	64,0	MKBU6N2
	40,0 - 46,0	41,0	85	85	94,0	64,0	MKBU7SN1
NPT 4"	46,0 - 52,0	41,0	85	85	94,0	64,0	MKBU7SN2
	45,0 - 52,0	41,0	95	90	105,0	79,0	MKBU7N1
	52,0 - 60,0	41,0	95	90	105,0	79,0	MKBU7N2
NPT 4 1/2"	45,0 - 52,0	43,0	95	95	105,0	79,0	MKBU8SN1
	52,0 - 60,0	43,0	95	95	105,0	79,0	MKBU8SN2
	60,0 - 66,0	43,0	115	110	127,0	86,0	MKBU8N1
NPT 5"	66,0 - 72,0	43,0	115	110	127,0	86,0	MKBU8N2

Barrier Cable Glands for Non-armoured Cables

CENTAURUS-N BARRIER for Mining Applications

Technical Details		
Material	Body, Cap	Brass, Brass Nickel Plated, Stainless Steel 316L
	Inner Part	Brass, Brass Nickel Plated, Stainless Steel 316L
	Seal	Silicone
	O-ring	Silicone
Ingress Protection Rating	IP 68 - 5 Bar, 30 min IP 66	
Operating Temperature	Seal Material	Silicone
		-60°C to +60°C
Service Temperature	Seal Material	Silicone
		-60°C to +100°C
Equipment For	Mining potentially explosive atmospheres	
Suitable for use in	Group I Mining Group IM	
Equipment Marking	Ex I M - Ex db IMb Ex eb IMb	
Marking Example*	BMD KBCTN.. Ex CE 0722  I M2 Ex db I Mb Ex eb I Mb IP66/68 Ta -60°C to +60°C CESI 17 ATEX 007X IECEx CES 17.0029X	
Thread Type	<ul style="list-style-type: none"> • Metric (M) ISO Pitch 1,5 • NPT (N) ANSI ASME B1.20.1 • Other thread types also available upon request. 	
Cable Type	Non Armoured	
Accessories	<ul style="list-style-type: none"> • Lock nuts • Gaskets (Washers) • Serrated Washers • Shrouds • Earth tags 	
	<ul style="list-style-type: none"> • O-ring available in Metric and NPT outer threads. • Accessories must be ordered separately. 	
	Remarks	
	Approvals	Certificate Number
	CESI 17 ATEX 0007X	EN 60079-0:2012+A11:2013 EN 60079-1:2014 EN 60079-7:2015 EN 60079-31:2014
	IECEx CES 17.0029X	IEC 60079-0:2011 Edition:6 IEC 60079-1:2014 Edition:7 IEC 60079-31:2013 Edition:2 IEC 60079-7:2015-08 Edition:5
	№ TC RU C-TR.AA87.B.00941	ГОСТ 31610.0-2014 ГОСТ IEC 60079-1:2013 ГОСТ IEC 60079-31:2013
-For more information see our webpage.		
* The standard marking consists ATEX & IECEx only. Marking acc. to other standards on request.		



Order Coding								
Part Number	Material	Seal	- Group	Gasket (Washer)	Serrated Washer	Lock Nut	Shroud	Earth Tag
Mandatory	Mandatory	Mandatory	- Mandatory	Option	Option	Option	Option	Option
See table	B Brass BN Brass Nickel plated X Stainless steel 316L	S Silicone	- M Group I (Mining)	WC Chloroprene WS Silicone WF Fiber	WSR Serrated washer	L Lock nut	S Shroud	E Earth tag
Example								
KBCTN5N	BN	C	- M	-	WSR	L	S	-

CENTAURUS-N BARRIER for Mining Applications

Barrier Cable Glands for Non-Armoured Cables

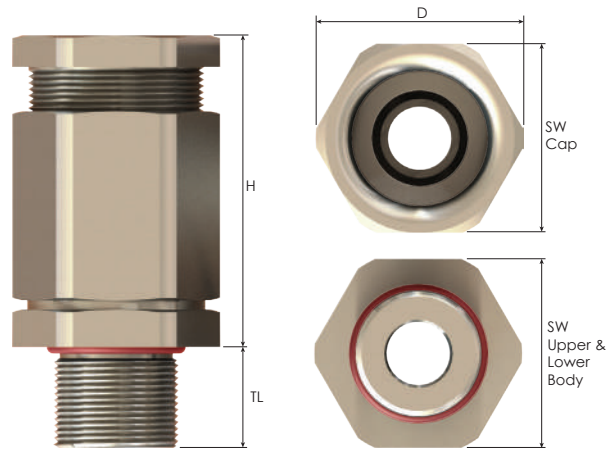

Thread Type METRIC acc. to ISO 965-3

Outer Thread Size (Male)	Clamping Range Ø min-max mm	Over Conductors max Ø mm	Outer Thread Length TL mm	Spanner Width			Outer Ø D mm	max. Height H mm	Part Number	Need Barrier Compound Material Per Pcs. (g)
				Cap SW Cap mm	Upper Body SW Upper Body mm	Lower Body SW Lower Body mm				
M20x1,5	6,0 - 13,0	9,5	16,0	25	25	25	27,0	51,0	KBCTN1SM	7
	8,0 - 15,0	9,5	16,0	25	25	25	27,0	51,0	KBCTN1M	7
	13,5 - 21,0	12,0	16,0	30	30	30	33,0	52,5	KBCTN1LM	6
M25x1,5	8,0 - 15,0	9,5	16,0	25	25	30	33,0	51,0	KBCTN2SM	7
	13,5 - 21,0	12,0	16,0	30	30	30	33,0	52,5	KBCTN2M	6
	18,0 - 27,0	15,0	16,0	40	40	40	44,5	60,0	KBCTN2LM	14
M32x1,5	18,0 - 27,0	15,0	16,0	40	40	40	44,5	60,0	KBCTN3M	14
	23,0 - 33,0	21,5	16,0	43	43	43	47,0	61,5	KBCTN3LM	26
M40x1,5	23,0 - 33,0	21,5	16,0	43	43	45	50,0	61,5	KBCTN4SM	26
	29,0 - 40,0	29,0	16,0	50	50	50	55,5	69,5	KBCTN4M	50
M50x1,5	29,0 - 40,0	29,0	16,0	50	50	55	61,0	69,5	KBCTN5SM	50
	35,0 - 48,0	37,0	16,0	58	58	58	64,0	75,0	KBCTN5M	82
M63x1,5	35,0 - 48,0	37,0	20,0	58	58	68	75,0	75,0	KBCTN6SM	82
	42,0 - 56,0	46,0	20,0	75	75	75	83,0	97,5	KBCTN6M	180
M75x1,5	42,0 - 56,0	46,0	20,0	75	75	80	89,0	97,5	KBCTN7SM	180
	54,0 - 70,0	58,0	20,0	100	100	100	110,5	106,5	KBCTN7M	290
M90x1,5	54,0 - 70,0	58,0	20,0	100	100	100	110,5	106,5	KBCTN8M	290

*Barrier compound is served as 50 g standard.

Thread Type NPT acc. to ANSI ASME B1.20.1

Outer Thread Size (Male)	Clamping Range Ø min-max mm	Over Conductors max Ø mm	Outer Thread Length TL mm	Spanner Width			Outer Ø D mm	max. Height H mm	Part Number	Need Barrier Compound Material Per Pcs. (g)
				Cap SW Cap mm	Upper Body SW Upper Body mm	Lower Body SW Lower Body mm				
NPT 1/2"	6,0 - 13,0	9,5	21,0	25	25	25	27,0	51,0	KBCTN1SN	7
NPT 1/2"	8,0 - 15,0	9,5	21,0	25	25	25	27,0	51,0	KBCTN1N	7
	13,5 - 21,0	12,0	21,0	30	30	30	33,0	52,5	KBCTN1LN	6
NPT 3/4"	8,0 - 15,0	9,5	21,0	25	25	30	33,0	51,0	KBCTN2SN	7
	13,5 - 21,0	12,0	21,0	30	30	30	33,0	52,5	KBCTN2N	6
NPT 1"	18,0 - 27,0	15,0	21,0	40	40	40	44,5	60,0	KBCTN2LN	14
	18,0 - 27,0	15,0	26,0	40	40	40	44,5	60,0	KBCTN3N	14
	23,0 - 33,0	21,5	26,0	43	43	43	47,0	61,5	KBCTN3LN	26
NPT 1 1/4"	23,0 - 33,0	21,5	28,0	43	43	45	50,0	61,5	KBCTN4SN	26
	29,0 - 40,0	29,0	28,0	50	50	50	55,5	69,5	KBCTN4N	50
NPT 1 1/2"	29,0 - 40,0	29,0	28,0	50	50	55	61,0	69,5	KBCTN5N	50
NPT 2"	35,0 - 48,0	37,0	28,0	58	58	65	72,0	75,0	KBCTN6N	82
NPT 2 1/2"	42,0 - 56,0	46,0	41,0	75	75	80	89,0	97,5	KBCTN7N	180
NPT 3"	54,0 - 70,0	58,0	43,0	100	100	100	110,5	106,5	KBCTN8N	290

*Barrier compound is served as 50 g standard.

CABLE GLANDS for ARMoured CABLES for Gas & Dust Applications



Orion Universal	152 - 155
Orion Offshore	156 - 159
Orion	160 - 163
Orion Lead Sheathed	164 - 167
Corona Universal	168 - 171
Corona Offshore	172 - 175
Corona	176 - 179
Centaurus-A Barrier	180 - 181
E-Vela	182 - 183

Ex Glands / Group II-III / Gas & Dust



Explosive gases, vapors and dusts have different chemical properties that affect the likelihood and severity of an explosion. Such properties include flame temperature, minimum ignition energy, upper and lower explosive limits, and molecular weight. Empirical testing is done to determine parameters such as the maximum experimental safe gap, minimum ignition current, explosion pressure and time to peak pressure, spontaneous ignition temperature, and maximum rate of pressure rise. Every substance has a differing combination of properties but it is found that they can be ranked into similar ranges, simplifying the selection of equipment for hazardous areas.

Flammability of combustible liquids are defined by their flash-point. The flash-point is the temperature at which the material will generate sufficient quantity of vapor to form an ignitable mixture. The flash point determines if an area needs to be classified. A material may have a relatively low autoignition temperature yet if its flash-point is above the ambient temperature, then the area may not need to be classified. Conversely if the same material is heated and handled above its flash-point, the area must be classified.









Each chemical gas or vapour used in industry is classified into a gas group.

The boundaries and extent of these three dimensional zones should be decided by a competent person. There must be a site plan drawn up of the factory with the zones marked on.

Cable Glands for All Types of Armoured Cables

ORION UNIVERSAL



Technical Details	
Material	Body, Cap Brass, Brass Nickel Plated, Stainless Steel, Aluminium Inner Part Brass, Brass Nickel Plated, Stainless Steel, Aluminium Seal CR (Chloroprene), Silicone O-ring CR (Chloroprene), Silicone
Ingress Protection Rating	IP 68 - 5 Bar, 30 min IP 66
Operating Temperature	Seal Material CR (Chloroprene) -40°C to +100°C Silicone -60°C to +130°C
Standard	-40°C to +100°C
LT Type	-40°C to +80°C
Equipment For	Gas & Dust potentially explosive atmospheres
Suitable for use in	Group II Gas Group IIC ZONE1/ZONE2 Group III Dust Group IIIC ZONE21/ZONE 22
Equipment Marking	Ex II 2GD Ex db IIC Gb Ex eb IIC Gb Ex tb IIIC Db
Marking Example *	BMD KBAU.. CE 0722  II 2GD Ex db IIC Gb Ex eb IIC Gb Ex tb IIIC Db Ta-60°C +130°C IP66/68 CESI 13 ATEX 033X IECEx CES 13.0013X
Thread Type	<ul style="list-style-type: none"> • Metric (M) ISO Pitch 1,5 • NPT (N) ANSI ASME B1.20.1 • Other thread types also available upon request.
Cable Type	SWA - SWB - STA - PWA - AWA - Shielded
Accessories	<ul style="list-style-type: none"> • Lock nuts • Gaskets (Washers) • Serrated Washers • Shrouds • Earth tags
Remarks	<ul style="list-style-type: none"> • O-ring available in Metric outer threads. • Accessories must be ordered separately.
Approvals	Certificate Number Standards
	CESI 13 ATEX 033X EN 60079-0:2012+A11:2013 EN 60079-1:2014 EN 60079-7:2015 EN 60079-31:2014
	IECEx CES 13.0013X IEC 60079-0:2011 Edition:6 IEC 60079-1:2014 Edition:7 IEC 60079-31:2013 Edition:2 IEC 60079-7:2015-08 Edition:5
	20150612-E474828 20170315-E199260 UL 2225, CAN/CSA-C22.2 No. 60079-0:11 CAN/CSA-C22.2 No. 60079-7:12 CAN/CSA-C22.2 No. 60079-31:12 UL 514B UL 50E
	№ TC RU C-TR.AA87.B.00941 ГОСТ 31610.0-2014 ГОСТ IEC 60079-1:2013 ГОСТ IEC 60079-31:2013
	DNV 12.0053 X ABNT NBR IEC 60079-0:2013, ABNT NBR IEC 60079-1:2009, ABNT NBR IEC 60079-7:2008, ABNT NBR IEC 60079-31:2011
	E-14044 IEC/EN60079-0, IEC/EN60079-7, IEC/EN60079-31 IEC/EN60079-1, IEC/EN 62444
	MASC MS/18-0240X SANS (IEC) 60079-0 : 2011 SANS (IEC) 60079-1 : 2014 SANS (IEC) 60079-7 : 2007 SANS (IEC) 60079-31 : 2014
-For more information see our webpage. * The standard marking consists ATEX & IECEx only. Marking acc. to other standards on request.	



With armour reduction cone it can be used for shielded, SWB and STA cable. When armour reduction cone is taken out it can be used for armoured SWA and AWA cables.

Order Coding								
Part Number	Material	Seal	Gasket (Washer)	Serrated Washer	Lock Nut	Shroud	Earth Tag	
Mandatory	Mandatory	Mandatory	- Option	Option	Option	Option	Option	Option
See table	B Brass BN Brass nickel plated X Stainless steel 316L A Aluminium	C Chloroprene S Silicone	- WC Chloroprene WS Silicone WF Fiber	WSR Serrated washer	L Lock nut	S Shroud	E Earth tag	
Example KBAU4M	BN	S	- WC	WSR	L	S	E	

ORION UNIVERSAL

Cable Glands for All Types of Armoured Cables

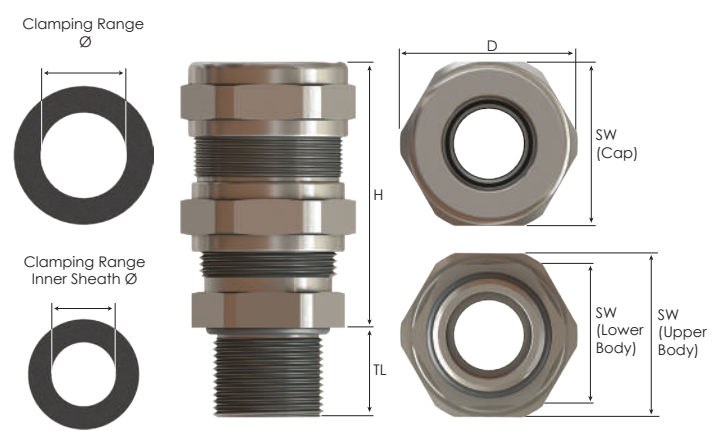

Thread Type **METRIC** acc. to ISO 965 - 3

Outer Thread Size (Male)	Clamping Range		Armour Wire Ø min-max mm	Shield Wire Ø min-max mm	Outer Thread Length TL mm	Cap SW Cap mm	Spanner Width		Outer Ø D mm	max. Height H mm	Part Number
	Inner Sheath Ø min-max mm	Ø min-max mm					Upper Body SW Upper Body mm	Lower Body SW Lower Body mm			
M12x1,5	3,0 - 7,5	6,0 - 12,0	0,70 - 1,20	0,2 - 0,5	15,0	26	26	22	29,0	50,5	KBAU0SLM
M16x1,5	3,0 - 8,5	6,0 - 12,0	0,70 - 1,20	0,2 - 0,5	16,0	26	26	22	29,0	49,5	KBAU015M
	6,0 - 12,0	8,5 - 16,0	0,70 - 1,25	0,2 - 0,5	16,0	29	29	25	31,5	52,0	KBAU01M
M20x1,5	3,0 - 8,5	6,0 - 12,0	0,70 - 1,20	0,2 - 0,5	16,0	26	26	24	29,0	50,0	KBAU1SM
	6,0 - 12,0	8,5 - 16,0	0,70 - 1,25	0,2 - 0,5	16,0	29	29	25	31,5	51,5	KBAU1M
	8,5 - 14,5	12,0 - 20,0	0,90 - 1,30	0,2 - 0,5	16,0	32	30	28	35,0	54,0	KBAU1LM
M25x1,5	3,0 - 8,5	6,0 - 12,0	0,70 - 1,20	0,2 - 0,5	18,0	26	26	29	31,5	50,0	KBAU2XSM
	6,0 - 12,0	8,5 - 16,0	0,70 - 1,25	0,2 - 0,5	18,0	29	29	29	31,5	52,5	KBAU2SM
	8,5 - 16,0	12,0 - 21,0	0,70 - 1,20	0,5 - 0,7	18,0	34	34	32	37,0	56,5	KBAU2M
	12,0 - 20,0	16,0 - 26,0	1,30 - 1,70	0,2 - 0,5	18,0	40	40	36	44,0	63,0	KBAU2LM
M32x1,5	6,0 - 12,0	8,5 - 16,0	0,70 - 1,25	0,2 - 0,5	18,0	29	29	36	39,8	52,5	KBAU3XSM
	12,0 - 20,0	16,0 - 26,0	1,30 - 1,70	0,2 - 0,5	18,0	40	40	40	44,0	64,0	KBAU3SM
	15,0 - 26,0	20,0 - 33,0	1,20 - 1,80	0,2 - 0,8	18,0	52	52	48	57,0	81,0	KBAU3M
M40x1,5	12,0 - 20,0	16,0 - 26,0	1,30 - 1,70	0,2 - 0,5	18,0	40	40	45	50,0	64,0	KBAU4XSM
	15,0 - 26,0	20,0 - 33,0	1,20 - 1,80	0,2 - 0,8	18,0	52	52	48	57,0	81,0	KBAU4SM
	20,0 - 32,0	29,0 - 41,0	1,60 - 2,20	0,2 - 0,8	18,0	60	60	55	66,0	92,0	KBAU4M
M50x1,5	15,0 - 26,0	20,0 - 33,0	1,20 - 1,80	0,2 - 0,8	18,0	52	52	54	60,0	81,0	KBAU5XSM
	20,0 - 32,0	29,0 - 41,0	1,60 - 2,20	0,2 - 0,8	18,0	60	60	55	66,0	92,0	KBAU5SM
	22,0 - 35,0	33,0 - 48,0	2,00 - 2,80	0,2 - 1,0	18,0	75	70	60	83,0	100,0	KBAU5SM
	27,0 - 41,0	36,0 - 52,0	1,80 - 2,80	0,3 - 1,4	18,0	74	70	70	81,8	104,5	KBAU5M
M63x1,5	22,0 - 35,0	33,0 - 48,0	2,00 - 2,80	0,2 - 1,0	20,0	75	70	68	83,0	100,0	KBAU6XSM
	27,0 - 41,0	36,0 - 52,0	1,80 - 2,80	0,3 - 1,4	20,0	74	70	70	81,8	104,5	KBAU6XMM
	35,0 - 45,0	43,0 - 57,0	1,80 - 2,80	0,3 - 1,0	20,0	80	80	75	89,5	109,5	KBAU6SM
	40,0 - 52,0	47,0 - 60,0	1,80 - 2,80	0,6 - 1,5	20,0	85	85	85	94,0	111,5	KBAU6M
M75x1,5	35,0 - 45,0	43,0 - 57,0	1,80 - 2,80	0,3 - 1,0	20,0	80	80	85	94,0	109,5	KBAU7XSM
	40,0 - 52,0	47,0 - 60,0	1,80 - 2,80	0,6 - 1,5	20,0	85	85	85	94,0	111,5	KBAU7SM
	45,0 - 60,0	54,0 - 70,0	1,00 - 2,30	0,2 - 1,2	20,0	100	95	90	110,5	127,5	KBAU7M
M90x1,5	40,0 - 52,0	47,0 - 60,0	1,80 - 2,80	0,6 - 1,5	20,0	85	85	100	110,5	111,5	KBAU8XSM
	45,0 - 60,0	54,0 - 70,0	1,00 - 2,30	0,2 - 1,2	20,0	100	95	95	110,5	127,5	KBAU8SM
	60,0 - 72,0	63,0 - 80,0	1,00 - 3,50	0,2 - 1,9	20,0	115	115	110	127,0	158,0	KBAU8M
M110x1,5	45,0 - 60,0	54,0 - 70,0	1,00 - 2,30	0,2 - 1,2	20,0	100	95	120	128,0	127,5	KBAU10SM
	60,0 - 72,0	63,0 - 80,0	1,00 - 3,50	0,2 - 1,9	20,0	115	115	120	128,0	158,0	KBAU10M























Thread Type **METRIC** acc. to ISO 965 - 3 (LT Type)

Outer Thread Size (Male)	Clamping Range		Armour Wire Ø min-max mm	Shield Wire Ø min-max mm	Outer Thread Length TL mm	Cap SW Cap mm	Spanner Width		Outer Ø D mm	max. Height H mm	Part Number
	Inner Sheath Ø min-max mm	Ø min-max mm					Upper Body SW Upper Body mm	Lower Body SW Lower Body mm			
M90x2,0	70,0 - 82,0	78,0 - 90,0	1,5 - 4,4	0,2 - 2,4	20,0	120	120	120	134,0	159,5	KBAU8MLT
M100x2,0	80,0 - 92,0	88,0 - 100,0	1,2 - 4,0	0,2 - 2,2	20,0	135	135	135	150,0	169,0	KBAU9SMLT
M110x2,0	90,0 - 101,0	98,0 - 110,0	2,1 - 5,4	0,2 - 3,1	20,0	145	145	145	162,0	180,0	KBAU10MLT
M130x2,0	100,0 - 115,0	109,0 - 123,0	2,0 - 5,4	0,2 - 3,0	24,0	160	160	160	176,0	202,0	KBAU13MLT

Cable Glands for All Types of Armoured Cables

ORION UNIVERSAL



Technical Details																	
Material	Body, Cap Brass, Brass Nickel Plated, Stainless Steel, Aluminium Inner Part Brass, Brass Nickel Plated, Stainless Steel, Aluminium Seal CR (Chloroprene), Silicone O-ring CR (Chloroprene), Silicone																
Ingress Protection Rating	IP 68 - 5 Bar, 30 min IP 66																
Operating Temperature	Seal Material CR (Chloroprene) -40°C to +100°C Silicone -60°C to +130°C																
Standard	-40°C to +100°C																
LT Type	-40°C to +80°C																
Equipment For	Gas & Dust potentially explosive atmospheres																
Suitable for use in	Group II Gas Group IIC ZONE1/ZONE2 Group III Dust Group IIIC ZONE21/ZONE 22																
Equipment Marking	Ex II 2GD Ex db IIC Gb Ex eb IIC Gb Ex tb IIIC Db																
Marking Example *	BMD KBAU.. CE 0722  II 2GD Ex db IIC Gb Ex eb IIC Gb Ex tb IIIC Db Ta-60°C +130°C IP66/68 CESI 13 ATEX 033X IECEx CES 13.0013X																
Thread Type	<ul style="list-style-type: none"> • Metric (M) ISO Pitch 1,5 • NPT (N) ANSI ASME B1.20.1 • Other thread types also available upon request. 																
Cable Type	SWA - SWB - STA - PWA - AWA - Shielded																
Accessories	<ul style="list-style-type: none"> • Lock nuts • Gaskets (Washers) • Serrated Washers • Shrouds • Earth tags 																
Remarks	<ul style="list-style-type: none"> • O-ring available in Metric outer threads. • Accessories must be ordered separately. 																
Approvals	<table border="1"> <thead> <tr> <th>Certificate Number</th> <th>Standards</th> </tr> </thead> <tbody> <tr> <td> CESI 13 ATEX 033X</td> <td>EN 60079-0:2012+A11:2013 EN 60079-1:2014 EN 60079-7:2015 EN 60079-31:2014</td> </tr> <tr> <td> IECEx CES 13.0013X</td> <td>IEC 60079-0:2011 Edition:6 IEC 60079-1:2014 Edition:7 IEC 60079-31:2013 Edition:2 IEC 60079-7:2015-08 Edition:5</td> </tr> <tr> <td> 20150612-E474828 20170315-E199260</td> <td>UL 2225, CAN/CSA-C22.2 No. 60079-0:11 CAN/CSA C22.2 No. 60079-7:12 CAN/CSA-C22.2 No. 60079-31:12 UL 514B UL 50E</td> </tr> <tr> <td> № TC RU C-TR.AA87.B.00941</td> <td>ГОСТ 31610.0-2014 ГОСТ IEC 60079-1:2013 ГОСТ IEC 60079-31:2013</td> </tr> <tr> <td> DNV 12.0053 X</td> <td>ABNT NBR IEC 60079-0:2013, ABNT NBR IEC 60079-1:2009, ABNT NBR IEC 60079-7:2008, ABNT NBR IEC 60079-31:2011</td> </tr> <tr> <td> E-14044</td> <td>IEC/EN60079-0, IEC/EN60079-7, IEC/EN60079-31 IEC/EN60079-1, IEC/EN 62444</td> </tr> <tr> <td> MASC MS/18-0240X</td> <td>SANS (IEC) 60079-0 : 2011 SANS (IEC) 60079-1 : 2014 SANS (IEC) 60079-7 : 2007 SANS (IEC) 60079-31 : 2014</td> </tr> </tbody> </table>	Certificate Number	Standards	 CESI 13 ATEX 033X	EN 60079-0:2012+A11:2013 EN 60079-1:2014 EN 60079-7:2015 EN 60079-31:2014	 IECEx CES 13.0013X	IEC 60079-0:2011 Edition:6 IEC 60079-1:2014 Edition:7 IEC 60079-31:2013 Edition:2 IEC 60079-7:2015-08 Edition:5	 20150612-E474828 20170315-E199260	UL 2225, CAN/CSA-C22.2 No. 60079-0:11 CAN/CSA C22.2 No. 60079-7:12 CAN/CSA-C22.2 No. 60079-31:12 UL 514B UL 50E	 № TC RU C-TR.AA87.B.00941	ГОСТ 31610.0-2014 ГОСТ IEC 60079-1:2013 ГОСТ IEC 60079-31:2013	 DNV 12.0053 X	ABNT NBR IEC 60079-0:2013, ABNT NBR IEC 60079-1:2009, ABNT NBR IEC 60079-7:2008, ABNT NBR IEC 60079-31:2011	 E-14044	IEC/EN60079-0, IEC/EN60079-7, IEC/EN60079-31 IEC/EN60079-1, IEC/EN 62444	 MASC MS/18-0240X	SANS (IEC) 60079-0 : 2011 SANS (IEC) 60079-1 : 2014 SANS (IEC) 60079-7 : 2007 SANS (IEC) 60079-31 : 2014
Certificate Number	Standards																
 CESI 13 ATEX 033X	EN 60079-0:2012+A11:2013 EN 60079-1:2014 EN 60079-7:2015 EN 60079-31:2014																
 IECEx CES 13.0013X	IEC 60079-0:2011 Edition:6 IEC 60079-1:2014 Edition:7 IEC 60079-31:2013 Edition:2 IEC 60079-7:2015-08 Edition:5																
 20150612-E474828 20170315-E199260	UL 2225, CAN/CSA-C22.2 No. 60079-0:11 CAN/CSA C22.2 No. 60079-7:12 CAN/CSA-C22.2 No. 60079-31:12 UL 514B UL 50E																
 № TC RU C-TR.AA87.B.00941	ГОСТ 31610.0-2014 ГОСТ IEC 60079-1:2013 ГОСТ IEC 60079-31:2013																
 DNV 12.0053 X	ABNT NBR IEC 60079-0:2013, ABNT NBR IEC 60079-1:2009, ABNT NBR IEC 60079-7:2008, ABNT NBR IEC 60079-31:2011																
 E-14044	IEC/EN60079-0, IEC/EN60079-7, IEC/EN60079-31 IEC/EN60079-1, IEC/EN 62444																
 MASC MS/18-0240X	SANS (IEC) 60079-0 : 2011 SANS (IEC) 60079-1 : 2014 SANS (IEC) 60079-7 : 2007 SANS (IEC) 60079-31 : 2014																

-For more information see our webpage.
* The standard marking consists ATEX & IECEx only. Marking acc. to other standards on request.



With armour reduction cone it can be used for shielded, SWB and STA cable. When armour reduction cone is taken out it can be used for armoured SWA and AWA cables.

Order Coding								
Part Number	Material	Seal	-	Gasket (Washer)	Serrated Washer	Lock Nut	Shroud	Earth Tag
Mandatory	Mandatory	Mandatory	-	Option	Option	Option	Option	Option
See table	B Brass BN Brass nickel plated X Stainless steel 316L A Aluminium	C Chloroprene S Silicone	-	WC Chloroprene WS Silicone WF Fiber	WSR Serrated washer	L Lock nut	S Shroud	E Earth tag
Example KBAU4M	BN	S	-	WC	WSR	L	S	E

ORION UNIVERSAL

Cable Glands for All Type of Armoured Cables

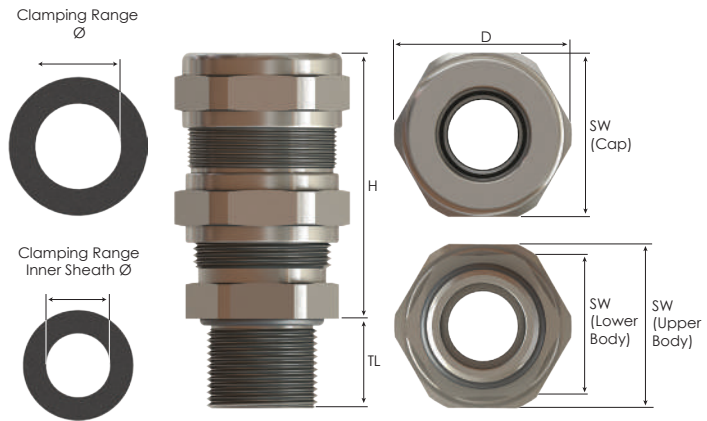

Thread Type **NPT** acc. to ANSI ASME B1.20.1

Outer Thread Size (Male)	Clamping Range		Armour Wire Ø min - max mm	Shield Wire Ø min - max mm	Outer Thread Length TL mm	Cap SW Cap mm	Spanner Width		Outer Ø D mm	max. Height H mm	Part Number
	Inner Sheath Ø min - max mm	Ø min - max mm					Upper Body SW Upper Body mm	Lower Body SW Lower Body mm			
NPT 1/4"	3,0 - 8,0	6,0 - 12,0	0,70 - 1,20	0,2 - 0,5	15,0	26	26	22	29,0	50,0	KBAU0SLN
NPT 3/8"	3,0 - 8,5	6,0 - 12,0	0,70 - 1,20	0,2 - 0,5	16,0	26	26	22	29,0	49,5	KBAU01SN
	6,0 - 12,0	8,5 - 16,0	0,70 - 1,25	0,2 - 0,5	16,0	29	29	25	31,5	52,0	KBAU01N
NPT 1/2"	3,0 - 8,5	6,0 - 12,0	0,70 - 1,20	0,2 - 0,5	16,0	26	26	24	29,0	49,5	KBAU1SN
	6,0 - 12,0	8,5 - 16,0	0,70 - 1,25	0,2 - 0,5	16,0	29	29	25	31,5	51,0	KBAU1N
	8,5 - 14,5	12,0 - 20,0	0,90 - 1,30	0,2 - 0,5	16,0	32	30	28	35,0	54,0	KBAU1LN
NPT 3/4"	3,0 - 8,5	6,0 - 12,0	0,70 - 1,20	0,2 - 0,5	16,0	26	26	29	31,5	50,0	KBAU2XSN
	6,0 - 12,0	8,5 - 16,0	0,70 - 1,25	0,2 - 0,5	18,0	29	29	29	31,5	52,5	KBAU2SN
	8,5 - 16,0	12,0 - 21,0	0,70 - 1,20	0,5 - 0,7	16,0	34	34	32	37,0	56,5	KBAU2N
	12,0 - 20,0	16,0 - 26,0	1,30 - 1,70	0,2 - 0,5	16,0	40	40	36	44,0	62,5	KBAU2LN
NPT 1"	6,0 - 12,0	8,5 - 16,0	0,70 - 1,25	0,2 - 0,5	21,0	29	29	36	39,8	52,5	KBAU3XSN
	12,0 - 20,0	16,0 - 26,0	1,30 - 1,70	0,2 - 0,5	21,0	40	40	40	44,0	64,0	KBAU3SN
	15,0 - 26,0	20,0 - 33,0	1,20 - 1,80	0,2 - 0,8	21,0	52	52	48	57,0	80,5	KBAU3N
NPT 1 1/4"	12,0 - 20,0	16,0 - 26,0	1,30 - 1,70	0,2 - 0,5	21,0	40	40	45	50,0	64,0	KBAU4XSN
	15,0 - 26,0	20,0 - 33,0	1,20 - 1,80	0,2 - 0,8	21,0	52	52	48	57,0	81,0	KBAU4SN
	20,0 - 32,0	29,0 - 41,0	1,60 - 2,20	0,2 - 0,8	18,0	60	60	55	66,0	92,0	KBAU4N
NPT 1 1/2"	15,0 - 26,0	20,0 - 33,0	1,20 - 1,80	0,2 - 0,8	21,0	52	52	54	60,0	81,0	KBAU5XSN
	20,0 - 32,0	29,0 - 41,0	1,60 - 2,20	0,2 - 0,8	21,0	60	60	55	66,0	92,0	KBAU5XMN
	22,0 - 35,0	33,0 - 48,0	2,00 - 2,80	0,2 - 1,0	21,0	75	70	60	83,0	100,0	KBAU5SN
	27,0 - 41,0	36,0 - 52,0	1,80 - 2,80	0,3 - 1,4	21,0	74	70	70	81,8	104,5	KBAU5N
NPT 2"	22,0 - 35,0	33,0 - 48,0	2,00 - 2,80	0,2 - 1,0	21,0	75	70	68	83,0	100,0	KBAU6XSN
	27,0 - 41,0	36,0 - 52,0	1,80 - 2,80	0,3 - 1,4	21,0	74	70	70	81,8	104,5	KBAU6XMN
	35,0 - 45,0	43,0 - 57,0	1,80 - 2,80	0,3 - 1,0	20,0	80	80	75	89,5	109,5	KBAU6SN
	40,0 - 52,0	47,0 - 60,0	1,80 - 2,80	0,6 - 1,5	21,0	85	85	85	94,0	111,5	KBAU6N
NPT 2 1/2"	35,0 - 45,0	43,0 - 57,0	1,80 - 2,80	0,3 - 1,0	21,0	80	80	80	89,5	109,0	KBAU7XSN
	40,0 - 52,0	47,0 - 60,0	1,80 - 2,80	0,6 - 1,5	21,0	85	85	85	94,0	111,5	KBAU7SN
	45,0 - 60,0	54,0 - 70,0	1,00 - 2,30	0,2 - 1,2	20,0	100	95	90	110,5	127,5	KBAU7N
NPT 3"	40,0 - 52,0	47,0 - 60,0	1,80 - 2,80	0,6 - 1,5	21,0	85	85	95	105,0	111,5	KBAU8XSN
	45,0 - 60,0	54,0 - 70,0	1,00 - 2,30	0,2 - 1,2	21,0	100	95	95	110,5	127,5	KBAU8SN
	60,0 - 72,0	63,0 - 80,0	1,00 - 3,50	0,2 - 1,9	21,0	115	115	110	127,0	158,0	KBAU8N
NPT 3 1/2"	45,0 - 60,0	54,0 - 70,0	1,00 - 2,30	0,2 - 1,2	21,0	100	95	110	123,0	127,5	KBAU9SN
	60,0 - 72,0	63,0 - 80,0	1,00 - 3,50	0,2 - 1,9	21,0	115	115	110	127,0	158,0	KBAU9N

Thread Type **NPT** acc. to ANSI ASME B1.20.1 (LT Type)

Outer Thread Size (Male)	Clamping Range		Armour Wire Ø min - max mm	Shield Wire Ø min - max mm	Outer Thread Length TL mm	Cap SW Cap mm	Spanner Width		Outer Ø D mm	max. Height H mm	Part Number
	Inner Sheath Ø min - max mm	Ø min - max mm					Upper Body SW Upper Body mm	Lower Body SW Lower Body mm			
NPT 3 1/2"	70,0 - 82,0	78,0 - 90,0	1,5 - 4,4	0,2 - 2,4	45,0	120	120	120	134,0	159,5	KBAU9MNL
NPT 4"	80,0 - 92,0	88,0 - 100,0	1,2 - 4,0	0,2 - 2,2	46,0	135	135	135	150,0	169,0	KBAU10SNLT
	90,0 - 101,0	98,0 - 110,0	2,1 - 5,4	0,2 - 3,1	46,0	145	145	145	162,0	180,0	KBAU10NLT
NPT 5"	100,0 - 115,0	109,0 - 123,0	2,0 - 5,4	0,2 - 3,0	48,0	160	160	160	176,0	202,0	KBAU11SNLT

Cable Glands for SWB, STA and Shielded Cables

ORION OFFSHORE



Technical Details		
Material	Body, Cap	Brass, Brass Nickel Plated, Stainless Steel, Aluminium
	Inner Part	Brass, Brass Nickel Plated, Stainless Steel, Aluminium
	Seal	CR (Chloroprene), Silicone
	O-ring	CR (Chloroprene), Silicone
Ingress Protection Rating	IP 68 - 5 Bar, 30 min IP 66	
Operating Temperature	Seal Material	
	CR (Chloroprene)	Silicone
		-40°C to +100°C
		-60°C to +130°C
Equipment For	Gas & Dust potentially explosive atmospheres	
Suitable for use in	Group II	Gas Group IIC
	Group III	Dust Group III C
Equipment Marking	Ex II 2GD Ex db IIC Gb Ex eb IIC Gb Ex tb IIC Db	
Marking Example *	BMD KBAO.. CE 0722  II 2GD Ex db IIC Gb Ex eb IIC Gb Ex tb IIC Db	
	Ta -40°C +100°C IP66/68 CESI 13 ATEX 033X IECEx CES 13.0013X	
Thread Type	<ul style="list-style-type: none"> • Metric (M) ISO Pitch 1,5 • NPT (N) ANSI ASME B1.20.1 • Other thread types also available upon request. 	
Cable Type	SWB - STA - Shielded	
Accessories	• Lock nuts	
	• Gaskets (Washers)	
	• Serrated Washers	
	• Shrouds	
	• Earth tags	
Remarks	<ul style="list-style-type: none"> • O-ring available in Metric outer threads. • Accessories must be ordered separately. 	
Approvals	Certificate Number	Standards
	CESI 13 ATEX 033X	EN 60079-0:2012+A11:2013 EN 60079-1:2014 EN 60079-7:2015 EN 60079-31:2014
	IECEx CES 13.0013X	IEC 60079-0:2011 Edition:6 IEC 60079-1:2014 Edition:7 IEC 60079-31:2013 Edition:2 IEC 60079-7:2015-08 Edition:5
	20170315-E199260	UL 514B UL 50E
	№ TC RU C-TR.AA87.B.00941	ГОСТ 31610.0-2014 ГОСТ IEC 60079-1:2013 ГОСТ IEC 60079-31:2013
	DNV 12.0053 X	ABNT NBR IEC 60079-0:2013, ABNT NBR IEC 60079-1:2009, ABNT NBR IEC 60079-7:2008, ABNT NBR IEC 60079-31:2011
	E-14044	IEC/EN60079-0, IEC/EN60079-7, IEC/EN60079-31 IEC/EN60079-1, IEC/EN 62444
	MASC MS/18-0240X	SANS (IEC) 60079-0 : 2011 SANS (IEC) 60079-1 : 2014 SANS (IEC) 60079-7 : 2007 SANS (IEC) 60079-31 : 2014

-For more information see our webpage.

* The standard marking consists ATEX & IECEx only. Marking acc. to other standards on request.



Order Coding								
Part Number	Material	Seal	-	Gasket (Washer)	Serrated Washer	Lock Nut	Shroud	Earth Tag
Mandatory	Mandatory	Mandatory	-	Option	Option	Option	Option	Option
See table	B Brass BN Brass nickel plated X Stainless steel 316L A Aluminium	C Chloroprene S Silicone	-	WC Chloroprene WS Silicone WF Fiber	WSR Serrated washer	L Lock nut	S Shroud	E Earth tag
Example	KBAO4M	BN	S	WC	WSR	L	S	E

ORION OFFSHORE

Cable Glands for SWB, STA and Shielded Cables

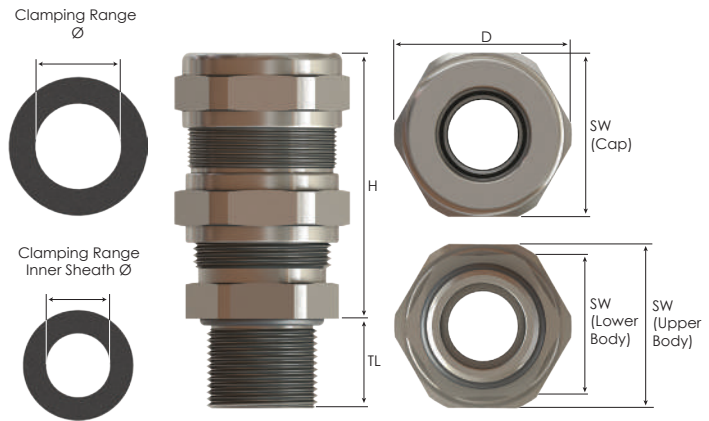

Thread Type **METRIC** acc. to ISO 965 - 3

Outer Thread Size (Male)	Clamping Range		Shield Wire Ø min-max mm	Outer Thread Length TL mm	Spanner Width			Outer Ø D mm	max. Height H mm	Part Number
	Inner Sheath Ø min-max mm	Ø min-max mm			Cap SW Cap mm	Upper Body SW Upper Body mm	Lower Body SW Lower Body mm			
M12x1,5	3,0 - 7,5	6,0 - 12,0	0,20 - 0,50	15	26	26	22	29,0	50,5	KBAO0SLM
	3,0 - 8,5	6,0 - 12,0	0,20 - 0,50	16	26	26	22	29,0	49,5	KBAO01SM
M16x1,5	6,0 - 12,0	8,5 - 16,0	0,20 - 0,50	16	29	29	25	31,5	52,0	KBAO01M
	3,0 - 8,5	6,0 - 12,0	0,20 - 0,50	16	26	26	24	29,0	50,0	KBAO1SM
M20x1,5	6,0 - 12,0	8,5 - 16,0	0,20 - 0,50	16	29	29	25	31,5	51,5	KBAO1M
	8,5 - 14,5	12,0 - 20,0	0,20 - 0,50	16	32	30	28	35,0	54,0	KBAO1LM
	3,0 - 8,5	6,0 - 12,0	0,20 - 0,50	18	26	26	29	31,5	50,0	KBAO2XSM
M25x1,5	6,0 - 12,0	8,5 - 16,0	0,20 - 0,50	18	29	29	29	31,5	52,5	KBAO2SM
	8,5 - 16,0	12,0 - 21,0	0,20 - 0,40	18	34	34	32	37,0	56,5	KBAO2M
	12,0 - 20,0	16,0 - 26,0	0,20 - 0,50	18	40	40	36	44,0	63,0	KBAO2LM
M32x1,5	6,0 - 12,0	8,5 - 16,0	0,20 - 0,50	18	29	29	36	39,8	52,5	KBAO3XSM
	12,0 - 20,0	16,0 - 26,0	0,20 - 0,50	18	40	40	40	44,0	64,0	KBAO3SM
	15,0 - 26,0	20,0 - 33,0	0,30 - 0,80	18	52	52	48	57,0	81,0	KBAO3M
M40x1,5	12,0 - 20,0	16,0 - 26,0	0,20 - 0,50	18	40	40	45	50,0	64,0	KBAO4XSM
	15,0 - 26,0	20,0 - 33,0	0,30 - 0,80	18	52	52	48	57,0	81,0	KBAO4SM
	20,0 - 32,0	29,0 - 41,0	0,15 - 0,75	18	60	60	55	66,0	92,0	KBAO4M
M50x1,5	15,0 - 26,0	20,0 - 33,0	0,30 - 0,80	18	52	52	54	60,0	81,0	KBAO5XSM
	20,0 - 32,0	29,0 - 41,0	0,15 - 0,75	18	60	60	55	66,0	92,0	KBAO5XMM
	22,0 - 35,0	33,0 - 48,0	0,25 - 0,90	18	75	70	60	83,0	100,0	KBAO5SM
M63x1,5	27,0 - 41,0	36,0 - 52,0	0,25 - 1,30	18	74	70	70	81,8	104,5	KBAO5M
	22,0 - 35,0	33,0 - 48,0	0,25 - 0,90	20	75	70	68	83,8	100,0	KBAO6XSM
	27,0 - 41,0	36,0 - 52,0	0,25 - 1,30	20	74	70	70	81,8	104,5	KBAO6XMM
M75x1,5	35,0 - 45,0	43,0 - 57,0	0,40 - 1,10	20	80	80	85	89,5	109,5	KBAO6SM
	40,0 - 52,0	47,0 - 60,0	0,30 - 1,30	20	85	85	85	94,0	111,5	KBAO6M
	35,0 - 45,0	43,0 - 57,0	0,40 - 1,10	20	80	80	85	94,0	109,5	KBAO7XSM
M90x1,5	40,0 - 52,0	47,0 - 60,0	0,30 - 1,40	20	85	95	90	110,5	127,5	KBAO7SM
	45,0 - 60,0	54,0 - 70,0	0,30 - 1,40	20	100	95	100	110,5	127,5	KBAO7M
	40,0 - 52,0	47,0 - 60,0	0,30 - 1,30	20	85	85	100	110,5	111,5	KBAO8XSM
M110x1,5	45,0 - 60,0	54,0 - 70,0	0,30 - 1,40	20	100	95	95	110,5	127,5	KBAO8SM
	60,0 - 72,0	63,0 - 80,0	0,30 - 3,30	20	115	115	110	127,0	158,0	KBAO8M
	45,0 - 60,0	54,0 - 70,0	0,30 - 1,40	20	100	95	120	128,0	127,5	KBAO10SM
	60,0 - 72,0	63,0 - 80,0	0,30 - 3,30	20	115	115	120	128,0	158,0	KBAO10M

Cable Glands for SWB, STA and Shielded Cables

ORION OFFSHORE



Technical Details			
Material	Body, Cap	Brass, Brass Nickel Plated, Stainless Steel, Aluminium	
	Inner Part	Brass, Brass Nickel Plated, Stainless Steel, Aluminium	
	Seal	CR (Chloroprene), Silicone	
	O-ring	CR (Chloroprene), Silicone	
Ingress Protection Rating	IP 68 - 5 Bar, 30 min IP 66		
Operating Temperature	Seal Material		
	CR (Chloroprene)	Silicone	
	-40°C to +100°C	-60°C to +130°C	
Equipment For	Gas & Dust potentially explosive atmospheres		
Suitable for use in	Group II	Gas Group IIC ZONE1/ZONE2	
	Group III	Dust Group III C ZONE21/ZONE 22	
Equipment Marking	Ex II 2GD Ex db IIC Gb Ex eb IIC Gb Ex tb IIC Db		
Marking Example *	BMD KBAO.. CE 0722  II 2GD Ex db IIC Gb Ex eb IIC Gb Ex tb IIC Db		
	Ta -40°C +100°C IP66/68 CESI 13 ATEX 033X IECEx CES 13.0013X		
Thread Type	<ul style="list-style-type: none"> • Metric (M) ISO Pitch 1,5 • NPT (N) ANSI ASME B1.20.1 • Other thread types also available upon request. 		
Cable Type	SWB - STA - Shielded		
Accessories	<ul style="list-style-type: none"> • Lock nuts • Gaskets (Washers) • Serrated Washers • Shrouds • Earth tags 		
	<ul style="list-style-type: none"> • O-ring available in Metric outer threads. • Accessories must be ordered separately. 		
	Approvals	Certificate Number	Standards
		CESI 13 ATEX 033X	EN 60079-0:2012+A11:2013 EN 60079-1:2014 EN 60079-7:2015 EN 60079-31:2014
		IECEX CES 13.0013X	IEC 60079-0:2011 Edition:6 IEC 60079-1:2014 Edition:7 IEC 60079-31:2013 Edition:2 IEC 60079-7:2015-08 Edition:5
	20170315-E199260	UL 514B UL 50E	
	№ TC RU C-TR.AA87.B.00941	ГОСТ 31610.0-2014 ГОСТ IEC 60079-1:2013 ГОСТ IEC 60079-31:2013	
	DNV 12.0053 X	ABNT NBR IEC 60079-0:2013, ABNT NBR IEC 60079-1:2009, ABNT NBR IEC 60079-7:2008, ABNT NBR IEC 60079-31:2011	
	E-14044	IEC/EN60079-0, IEC/EN60079-7, IEC/EN60079-31 IEC/EN60079-1, IEC/EN 62444	
	MASC MS/18-0240X	SANS (IEC) 60079-0 : 2011 SANS (IEC) 60079-1 : 2014 SANS (IEC) 60079-7 : 2007 SANS (IEC) 60079-31 : 2014	

- For more information see our webpage.

* The standard marking consists ATEX & IECEx only. Marking acc. to other standards on request.



ORION OFFSHORE

Cable Glands for SWB, STA and Shielded Cables

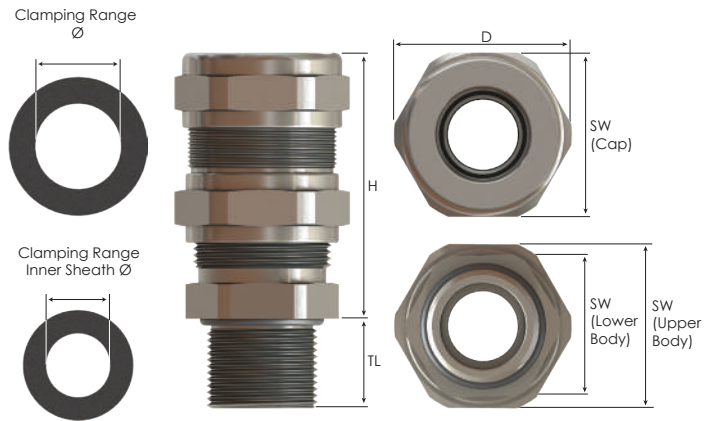









Thread Type NPT acc. to ANSI ASME B1.20.1											
Outer Thread Size (Male)	Clamping Range		Shield Wire Ø min-max mm	Outer Thread Length TL mm	Cap SW Cap mm	Spanner Width Upper Body		Lower Body SW Lower Body mm	Outer Ø D mm	max. Height H mm	Part Number
	Inner Sheath Ø min-max mm	Ø min-max mm				SW Upper Body mm	SW Lower Body mm				
NPT 1/4"	3,0 - 8,0	6,0 - 12,0	0,20 - 0,50	15,0	26	26	22	29,0	50,0	KBAO05LN	
	3,0 - 8,5	6,0 - 12,0	0,20 - 0,50	16,0	26	26	22	29,0	49,5	KBAO01SN KBAO01N	
NPT 3/8"	6,0 - 12,0	8,5 - 16,0	0,20 - 0,50	16,0	29	29	25	31,5	52,0	KBAO01N	
	3,0 - 8,5	6,0 - 12,0	0,20 - 0,50	21,0	26	26	24	29,0	49,5	KBAO1SN	
NPT 1/2"	6,0 - 12,0	8,5 - 16,0	0,20 - 0,50	21,0	29	29	25	31,5	51,0	KBAO1N	
	8,5 - 14,5	12,0 - 20,0	0,20 - 0,50	21,0	32	30	28	35,0	54,0	KBAO1LN	
	3,0 - 8,5	6,0 - 12,0	0,20 - 0,50	21,0	26	26	29	31,5	50,0	KBAO2XSN	
NPT 3/4"	6,0 - 12,0	8,5 - 16,0	0,20 - 0,50	21,0	29	29	29	31,5	52,5	KBAO2SN	
	8,5 - 16,0	12,0 - 21,0	0,20 - 0,40	21,0	34	34	32	37,0	56,5	KBAO2N	
	12,0 - 20,0	16,0 - 26,0	0,20 - 0,50	21,0	40	40	36	44,0	62,5	KBAO2LN	
NPT 1"	6,0 - 12,0	8,5 - 16,0	0,20 - 0,50	26,0	29	29	36	39,8	52,5	KBAO3XSN	
	12,0 - 20,0	16,0 - 26,0	0,20 - 0,50	26,0	40	40	40	44,0	64,0	KBAO3SN	
	15,0 - 26,0	20,0 - 33,0	0,30 - 0,80	26,0	52	52	48	57,0	80,5	KBAO3N	
NPT 1 1/4"	12,0 - 20,0	16,0 - 26,0	0,20 - 0,50	28,0	40	40	45	50,0	64,0	KBAO4XSN	
	15,0 - 26,0	20,0 - 33,0	0,30 - 0,80	28,0	52	52	48	57,0	81,0	KBAO4SN	
	20,0 - 32,0	29,0 - 41,0	0,15 - 0,75	28,0	60	60	55	66,0	92,0	KBAO4N	
NPT 1 1/2"	15,0 - 26,0	20,0 - 33,0	0,30 - 0,80	28,0	52	52	54	60,0	81,0	KBAO5XSN	
	20,0 - 32,0	29,0 - 41,0	0,15 - 0,75	28,0	60	60	55	66,0	92,0	KBAO5XMN	
	22,0 - 35,0	33,0 - 48,0	0,25 - 0,90	28,0	75	70	60	83,0	100,0	KBAO5SN	
	27,0 - 41,0	36,0 - 52,0	0,25 - 1,30	28,0	74	70	70	81,8	104,5	KBAO5N	
NPT 2"	22,0 - 35,0	33,0 - 48,0	0,25 - 0,90	28,0	75	70	68	83,0	100,0	KBAO6XSN	
	27,0 - 41,0	36,0 - 52,0	0,25 - 1,30	28,0	74	70	70	81,8	104,5	KBAO6XMN	
	35,0 - 45,0	43,0 - 57,0	0,40 - 1,10	28,0	80	80	75	89,5	109,5	KBAO6SN	
	40,0 - 52,0	47,0 - 60,0	0,30 - 1,30	28,0	85	85	85	94,0	111,5	KBAO6N	
NPT 2 1/2"	35,0 - 45,0	43,0 - 57,0	0,40 - 1,10	41,0	80	80	80	89,5	109,0	KBAO7XSN	
	40,0 - 52,0	47,0 - 60,0	0,30 - 1,30	41,0	85	85	85	94,0	111,5	KBAO7SN	
	45,0 - 60,0	54,0 - 70,0	0,30 - 1,40	41,0	100	95	90	110,5	127,5	KBAO7N	
NPT 3"	40,0 - 52,0	47,0 - 60,0	0,30 - 1,30	43,0	85	85	95	105,0	111,5	KBAO8XSN	
	45,0 - 60,0	54,0 - 70,0	0,30 - 1,40	43,0	100	95	95	110,5	127,5	KBAO8SN	
	60,0 - 72,0	63,0 - 80,0	0,30 - 3,30	43,0	115	115	110	127,0	158,0	KBAO8N	
NPT 3 1/2"	45,0 - 60,0	54,0 - 70,0	0,30 - 1,40	45,0	100	95	110	123,0	127,5	KBAO9SN	
	60,0 - 72,0	63,0 - 80,0	0,30 - 3,30	45,0	115	115	110	127,0	158,0	KBAO9N	

Cable Glands for SWA and AWA Cables

ORION



Technical Details			
Material	Body, Cap	Brass, Brass Nickel Plated, Stainless Steel, Aluminium	
	Inner Part	Brass, Brass Nickel Plated, Stainless Steel, Aluminium	
	Seal	CR (Chloroprene) , Silicone	
	O-ring	CR (Chloroprene) , Silicone	
Ingress Protection Rating	IP 68 - 5 Bar, 30 min IP 66		
Operating Temperature	Seal Material		
	CR (Chloroprene)	Silicone	
	Standard	-40°C to +100°C	-60°C to +130°C
LT Type	-40°C to +80°C	-60°C to +80°C	
Equipment For	Gas & Dust potentially explosive atmospheres		
Suitable for use in	Group II	Gas Group IIC	ZONE1/ZONE2
	Group III	Dust Group IIIC	ZONE21/ZONE 22
Equipment Marking	Ex II 2GD Ex db IIC Gb Ex eb IIC Gb Ex tb IIIC Db		
Marking Example *	BMD KBA.. CE 0722  II 2GD Ex db IIC Gb Ex eb IIC Gb Ex tb IIIC Db Ta -60°C to +130°C IP66/68 CESI 13 ATEX 033X IECEx CES 13.0013X		
Thread Type	<ul style="list-style-type: none"> • Metric (M) ISO Pitch 1,5 • NPT (N) ANSI ASME B1.20.1 • Other thread types also available upon request. 		
Cable Type	SWA - AWA		
Accessories	<ul style="list-style-type: none"> • Lock nuts • Gaskets (Washers) • Serrated Washers • Shrouds • Earth tags 		
	<ul style="list-style-type: none"> • O-ring available in Metric outer threads. • Accessories must be ordered separately. 		
	Approvals	Certificate Number	Standards
		CESI 13 ATEX 033X	EN 60079-0:2012+A11:2013 EN 60079-1:2014 EN 60079-7:2015 EN 60079-31:2014
		IECEX CES 13.0013X	IEC 60079-0:2011 Edition:6 IEC 60079-1:2014 Edition:7 IEC 60079-31:2013 Edition:2 IEC 60079-7:2015-08 Edition:5
	20150612-E474828	UL 2225, CAN/CSA-C22.2 No. 60079-0:11 CAN/CSA C22.2 No. 60079-7:12 CAN/CSA-C22.2 No. 60079-31:12	
	20170315-E199260	UL 514B UL50E	
	№ TC RU C-TR.AA87.B.00941	FOCT 31610.0-2014 FOCT IEC 60079-1:2013 FOCT IEC 60079-31:2013	
	DNV 12.0053 X	ABNT NBR IEC 60079-0:2013, ABNT NBR IEC 60079-1:2009, ABNT NBR IEC 60079-7:2008, ABNT NBR IEC 60079-31:2011	
	E-14044	IEC/EN60079-0, IEC/EN60079-7, IEC/EN60079-31 IEC/EN60079-1, IEC/EN 62444	
	MASC MS/18-0240X	SANS (IEC) 60079-0 : 2011 SANS (IEC) 60079-1 : 2014 SANS (IEC) 60079-7 : 2007 SANS (IEC) 60079-31 : 2014	

-For more information see our webpage.

* The standard marking consists ATEX & IECEx only. Marking acc. to other standards on request.

Order Coding							
Part Number	Material	Seal	Gasket (Washer)	Serrated Washer	Lock Nut	Shroud	Earth Tag
Mandatory	Mandatory	Mandatory	- Option	Option	Option	Option	Option
See table	B Brass BN Brass Nickel plated X Stainless steel A Aluminium	C Chloroprene S Silicone	- WC Chloroprene WS Silicone WF Fiber	WSR Serrated washer	L Lock nut	S Shroud	E Earth tag
Example							
KBA1N	BN	S	- WC	-	L	-	E

ORION

Cable Glands for SWA and AWA Cables

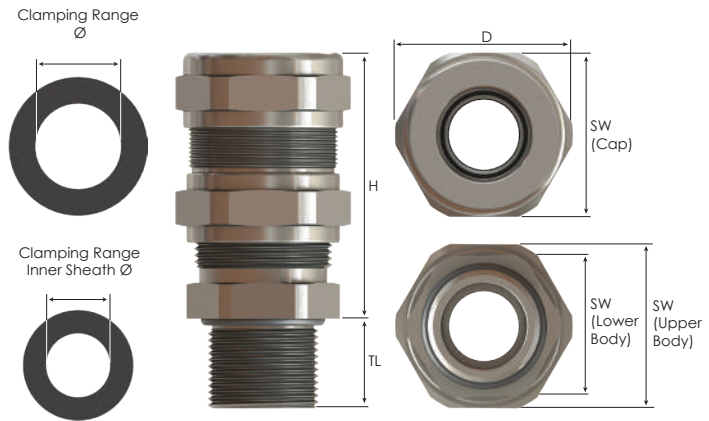

Thread Type **METRIC** acc. to ISO 965-3

Outer Thread Size (Male)	Clamping Range		Armour Wire Ø min-max mm	Outer Thread Length TL mm	Spanner Width Upper Body		Lower Body SW Lower Body mm	Outer Ø D mm	max. Height H mm	Part Number
	Inner Sheath Ø min-max mm	Ø min-max mm			Cap SW Cap mm	SW Upper Body mm				
M12x1,5	2,0 - 4,0	3,0 - 5,5	0,10 - 0,40	15,0	17	17	17	18,9	62,5	KBA0SM
	3,0 - 7,5	6,0 - 12,0	0,70 - 1,20	15,0	26	26	22	29,0	50,5	KBA0SLM
M16x1,5	3,0 - 8,5	6,0 - 12,0	0,70 - 1,20	16,0	26	26	22	29,0	49,5	KBA01SM
	6,0 - 12,0	8,5 - 16,0	0,70 - 1,25	16,0	29	29	25	31,5	52,0	KBA01M
M20x1,5	3,0 - 8,5	6,0 - 12,0	0,70 - 1,20	16,0	26	26	24	29,0	50,0	KBA1SM
	6,0 - 12,0	8,5 - 16,0	0,70 - 1,25	16,0	29	29	25	31,5	51,5	KBA1M
	8,5 - 14,5	12,0 - 20,0	0,90 - 1,30	16,0	32	30	28	35,0	54,0	KBA1LM
M25x1,5	3,0 - 8,5	6,0 - 12,0	0,70 - 1,20	18,0	26	26	29	31,5	50,0	KBA2XSM
	6,0 - 12,0	8,5 - 16,0	0,70 - 1,25	18,0	29	29	29	31,5	52,5	KBA2SM
	8,5 - 16,0	12,0 - 21,0	0,70 - 1,20	18,0	34	34	32	37,0	56,5	KBA2M
	12,0 - 20,0	16,0 - 26,0	1,30 - 1,70	18,0	40	40	36	44,0	63,0	KBA2LM
M32x1,5	6,0 - 12,0	8,5 - 16,0	0,70 - 1,25	18,0	29	29	36	39,8	52,5	KBA3XSM
	12,0 - 20,0	16,0 - 26,0	1,30 - 1,70	18,0	40	40	40	44,0	64,0	KBA3SM
	15,0 - 26,0	20,0 - 33,0	1,20 - 1,80	18,0	52	52	48	57,0	81,0	KBA3M
M40x1,5	12,0 - 20,0	16,0 - 26,0	1,30 - 1,70	18,0	40	40	45	50,0	64,0	KBA4XSM
	15,0 - 26,0	20,0 - 33,0	1,20 - 1,80	18,0	52	52	48	57,0	81,0	KBA4SM
	20,0 - 32,0	29,0 - 41,0	1,60 - 2,20	18,0	60	60	55	66,0	92,0	KBA4M
M50x1,5	15,0 - 26,0	20,0 - 33,0	1,20 - 1,80	18,0	52	52	54	60,0	81,0	KBA5XSM
	20,0 - 32,0	29,0 - 41,0	1,60 - 2,20	18,0	60	60	55	66,0	92,0	KBA5XMM
	22,0 - 35,0	33,0 - 48,0	2,00 - 2,80	18,0	75	70	60	83,0	100,0	KBA5SM
	27,0 - 41,0	36,0 - 52,0	1,80 - 2,80	18,0	74	70	70	81,8	104,5	KBA5M
M63x1,5	22,0 - 35,0	33,0 - 48,0	2,00 - 2,80	20,0	75	70	68	83,0	100,0	KBA6XSM
	27,0 - 41,0	36,0 - 52,0	1,80 - 2,80	20,0	74	70	70	81,8	104,5	KBA6XMM
	35,0 - 45,0	43,0 - 57,0	1,80 - 2,80	20,0	80	80	75	89,5	109,5	KBA6SM
	40,0 - 52,0	47,0 - 60,0	1,80 - 2,80	20,0	85	85	85	94,0	111,5	KBA6M
	45,0 - 56,0	54,0 - 70,0	1,30 - 2,50	20,0	100	95	90	110,5	128,5	KBA6LM
M75x1,5	35,0 - 45,0	43,0 - 57,0	1,80 - 2,80	20,0	80	80	85	94,0	109,5	KBA7XSM
	40,0 - 52,0	47,0 - 60,0	1,80 - 2,80	20,0	85	85	85	94,0	111,5	KBA7SM
	45,0 - 60,0	54,0 - 70,0	1,00 - 2,30	20,0	100	95	90	110,5	127,5	KBA7M
M90x1,5	40,0 - 52,0	47,0 - 60,0	1,80 - 2,80	20,0	85	85	100	110,5	111,5	KBA8XSM
	45,0 - 60,0	54,0 - 70,0	1,00 - 2,30	20,0	100	95	95	110,5	127,5	KBA8SM
	60,0 - 72,0	63,0 - 80,0	1,00 - 3,50	20,0	115	115	110	127,0	158,0	KBA8M
M110x1,5	45,0 - 60,0	54,0 - 70,0	1,00 - 2,30	20,0	100	95	120	128,0	127,5	KBA10SM
	60,0 - 72,0	63,0 - 80,0	1,00 - 3,50	20,0	115	115	120	128,0	158,0	KBA10M







Thread Type **METRIC** acc. to ISO 965-3 (LT Type)

Outer Thread Size (Male)	Clamping Range		Armour Wire Ø min-max mm	Outer Thread Length TL mm	Spanner Width Upper Body		Lower Body SW Lower Body mm	Outer Ø D mm	max. Height H mm	Part Number
	Inner Sheath Ø min-max mm	Ø min-max mm			Cap SW Cap mm	SW Upper Body mm				
M90x2,0	70,0 - 82,0	78,0 - 90,0	1,5 - 4,4	20,0	120	120	120	134,0	159,5	KBA8MLT
M100x2,0	80,0 - 92,0	88,0 - 100,0	1,2 - 4,0	20,0	135	135	135	150,0	169,0	KBA9SMLT
M110x2,0	90,0 - 101,0	98,0 - 110,0	2,1 - 5,4	20,0	145	145	145	162,0	180,0	KBA10MLT
M130x2,0	100,0 - 115,0	109,0 - 123,0	2,0 - 5,4	24,0	160	160	160	176,0	202,0	KBA13MLT

Cable Glands for Armoured Cables

ORION



Technical Details			
Material	Body, Cap	Brass, Brass Nickel Plated, Stainless Steel, Aluminium	
	Inner Part	Brass, Brass Nickel Plated, Stainless Steel, Aluminium	
	Seal	CR (Chloroprene) , Silicone	
	O-ring	CR (Chloroprene) , Silicone	
Ingress Protection Rating	IP 68 - 5 Bar, 30 min IP 66		
Operating Temperature	Seal Material		
	CR (Chloroprene)	Silicone	
	Standard	-40°C to +100°C	
LT Type	-40°C to +80°C	-60°C to +130°C	
Equipment For	Gas & Dust potentially explosive atmospheres		
Suitable for use in	Group II	Gas Group IIC	ZONE1/ZONE2
Equipment Marking	Group III	Dust Group IIIC	ZONE21/ZONE 22
Marking Example *	Ex II 2GD Ex db IIC Gb Ex eb IIC Gb Ex tb IIIC Db Ta -60°C to +130°C IP66/68 CESI 13 ATEX 033X IECEx CES 13.0013X		
Thread Type	<ul style="list-style-type: none"> • Metric (M) ISO Pitch 1,5 • NPT (N) ANSI ASME B1.20.1 • Other thread types also available upon request. 		
Cable Type	SWA - AWA		
Accessories	<ul style="list-style-type: none"> • Lock nuts • Gaskets (Washers) • Serrated Washers • Shrouds • Earth tags 		
	<ul style="list-style-type: none"> • O-ring available in Metric threads. • Accessories must be ordered separately. 		
Remarks			
Approvals	Certificate Number	Standards	
	CESI 13 ATEX 033X	EN 60079-0:2012+A11:2013 EN 60079-1:2014 EN 60079-7:2015 EN 60079-31:2014	
	IECEx CES 13.0013X	IEC 60079-0:2011 Edition:6 IEC 60079-1:2014 Edition:7 IEC 60079-31:2013 Edition:2 IEC 60079-7:2015-08 Edition:5	
	20150612-E474828	UL 2225, CAN/CSA-C22.2 No. 60079-0:11 CAN/CSA C22.2 No. 60079-7:12 CAN/CSA-C22.2 No. 60079-31:12	
	20170315-E199260	UL 514B UL50E	
	Nº TC RU C-TR.AA87.B.00941	ГОСТ 31610.0-2014 ГОСТ IEC 60079-1:2013 ГОСТ IEC 60079-31:2013	
	DNV 12.0053 X	ABNT NBR IEC 60079-0:2013, ABNT NBR IEC 60079-1:2009, ABNT NBR IEC 60079-7:2008, ABNT NBR IEC 60079-31:2011	
	E-14044	IEC/EN60079-0, IEC/EN60079-7, IEC/EN60079-31 IEC/EN60079-1, IEC/EN 62444	
	MASC MS/18-0240X	SANS (IEC) 60079-0 : 2011 SANS (IEC) 60079-1 : 2014 SANS (IEC) 60079-7 : 2007 SANS (IEC) 60079-31 : 2014	

-For more information see our webpage.

* The standard marking consists ATEX & IECEx only. Marking acc. to other standards on request.

Order Coding							
Part Number	Material	Seal	- Gasket (Washer)	Serrated Washer	Lock Nut	Shroud	Earth Tag
Mandatory	Mandatory	Mandatory	- Option	Option	Option	Option	Option
See table	B Brass BN Brass Nickel plated X Stainless steel A Aluminium	C Chloroprene S Silicone	- WC Chloroprene WS Silicone WF Fiber	WSR Serrated washer	L Lock nut	S Shroud	E Earth tag
Example							
KBA1N	BN	S	- WC	-	L	-	E

ORION Cable Glands for SWA and AWA Cables

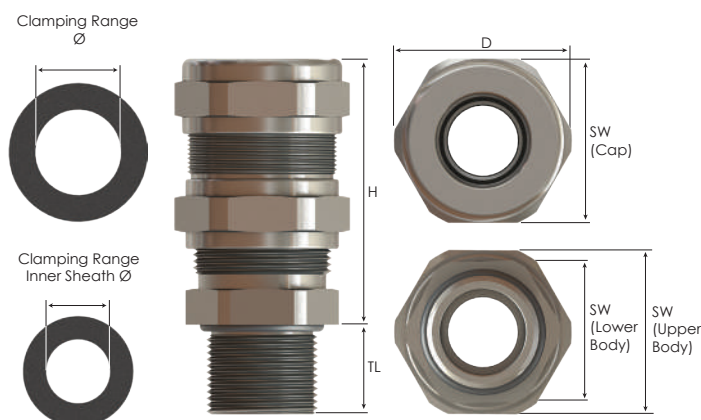

Thread Type **NPT** acc. to ANSI ASME B1.20.1

Outer Thread Size (Male)	Clamping Range		Armour Wire Ø min-max mm	Outer Thread Length TL mm	Spanner Width Upper Body		Lower Body SW Lower Body mm	Outer Ø D mm	max. Height H mm	Part Number
	Inner Sheath Ø min-max mm	Ø min-max mm			Cap SW Cap mm	SW Upper Body mm				
NPT 1/4"	2,0 - 4,0	3,0 - 5,5	0,10 - 0,40	15,0	17	17	17	18,9	62,5	KBA0SN
	3,0 - 8,0	6,0 - 12,0	0,70 - 1,20	15,0	26	26	22	29,0	50,0	KBA0SLN
NPT 3/8"	3,0 - 8,5	6,0 - 12,0	0,70 - 1,20	16,0	26	26	22	29,0	49,5	KBA01SN
	6,0 - 12,0	8,5 - 16,0	0,70 - 1,25	16,0	29	29	25	31,5	52,0	KBA01N
NPT 1/2"	3,0 - 8,5	6,0 - 12,0	0,70 - 1,20	21,0	26	26	24	29,0	49,5	KBA1SN
	6,0 - 12,0	8,5 - 16,0	0,70 - 1,25	21,0	29	29	25	31,5	51,0	KBA1N
	8,5 - 14,5	12,0 - 20,0	0,90 - 1,30	21,0	32	30	28	35,0	54,0	KBA1LN
NPT 3/4"	3,0 - 8,5	6,0 - 12,0	0,70 - 1,20	21,0	26	26	29	31,5	50,0	KBA2XSN
	6,0 - 12,0	8,5 - 16,0	0,70 - 1,25	21,0	29	29	29	31,5	52,5	KBA2SN
	8,5 - 16,0	12,0 - 21,0	0,70 - 1,20	21,0	34	34	32	37,0	56,5	KBA2N
	12,0 - 20,0	16,0 - 26,0	1,30 - 1,70	21,0	40	40	36	44,0	62,5	KBA2LN
NPT 1"	6,0 - 12,0	8,5 - 16,0	0,70 - 1,25	26,0	29	29	36	39,8	52,5	KBA3XSN
	12,0 - 20,0	16,0 - 26,0	1,30 - 1,70	26,0	40	40	40	44,0	64,0	KBA3SN
	15,0 - 26,0	20,0 - 33,0	1,20 - 1,80	26,0	52	52	48	57,0	80,5	KBA3N
NPT 1 1/4"	12,0 - 20,0	16,0 - 26,0	1,30 - 1,70	28,0	40	40	45	50,0	64,0	KBA4XSN
	15,0 - 26,0	20,0 - 33,0	1,20 - 1,80	28,0	52	52	48	57,0	81,0	KBA4SN
	20,0 - 32,0	29,0 - 41,0	1,60 - 2,20	28,0	60	60	55	66,0	92,0	KBA4N
NPT 1 1/2"	15,0 - 26,0	20,0 - 33,0	1,20 - 1,80	28,0	52	52	54	60,0	81,0	KBA5XSN
	20,0 - 32,0	29,0 - 41,0	1,60 - 2,20	28,0	60	60	55	66,0	92,0	KBA5XMN
	22,0 - 35,0	33,0 - 48,0	2,00 - 2,80	28,0	75	70	60	83,0	100,0	KBA5SN
	27,0 - 41,0	36,0 - 52,0	1,80 - 2,80	28,0	74	70	70	81,8	104,5	KBA5N
NPT 2"	22,0 - 35,0	33,0 - 48,0	2,00 - 2,80	28,0	75	70	68	83,0	100,0	KBA6XSN
	27,0 - 41,0	36,0 - 52,0	1,80 - 2,80	28,0	74	70	70	81,8	104,5	KBA6XMN
	35,0 - 45,0	43,0 - 57,0	1,80 - 2,80	28,0	80	80	75	89,5	109,5	KBA6SN
	40,0 - 52,0	47,0 - 60,0	1,80 - 2,80	28,0	85	85	85	94,0	111,5	KBA6N
	45,0 - 52,0	54,0 - 70,0	1,30 - 2,50	28,0	100	95	90	110,5	128,5	KBA6LN
NPT 2 1/2"	35,0 - 45,0	43,0 - 57,0	1,80 - 2,80	41,0	80	80	80	89,5	109,0	KBA7XSN
	40,0 - 52,0	47,0 - 60,0	1,80 - 2,80	41,0	85	85	85	94,0	111,5	KBA7SN
	45,0 - 60,0	54,0 - 70,0	1,00 - 2,30	41,0	100	95	90	110,5	127,5	KBA7N
NPT 3"	40,0 - 52,0	47,0 - 60,0	1,80 - 2,80	43,0	85	85	95	105,0	111,5	KBA8XSN
	45,0 - 60,0	54,0 - 70,0	1,00 - 2,30	43,0	100	95	95	110,5	127,5	KBA8SN
	60,0 - 72,0	63,0 - 80,0	1,00 - 3,50	43,0	115	115	110	127,0	158,0	KBA8N
NPT 3 1/2"	45,0 - 60,0	54,0 - 70,0	1,00 - 2,30	45,0	100	95	110	123,0	127,5	KBA9SN
	60,0 - 72,0	63,0 - 80,0	1,00 - 3,50	45,0	115	115	110	127,0	158,0	KBA9N

Thread Type **NPT** acc. to ANSI ASME B1.20.1 (LT Type)

Outer Thread Size (Male)	Clamping Range		Armour Wire Ø min-max mm	Outer Thread Length TL mm	Spanner Width Upper Body		Lower Body SW Lower Body mm	Outer Ø D mm	max. Height H mm	Part Number
	Inner Sheath Ø min-max mm	Ø min-max mm			Cap SW Cap mm	SW Upper Body mm				
NPT 3 1/2"	70,0 - 82,0	78,0 - 90,0	1,5 - 4,4	45,0	120	120	120	134,0	159,5	KBA9MNL
NPT 4"	80,0 - 92,0	88,0 - 100,0	1,2 - 4,0	46,0	135	135	135	150,0	169,0	KBA10SNLT
	90,0 - 101,0	98,0 - 110,0	2,1 - 5,4	46,0	145	145	145	162,0	180,0	KBA10NLT
NPT 5"	100,0 - 115,0	109,0 - 123,0	2,0 - 5,4	48,0	160	160	160	176,0	202,0	KBA11SNLT

Cable Glands for SWA and AWA Cables

ORION LEAD SHEATHED



Technical Details			
Material	Body, Cap	Brass, Brass Nickel Plated, Stainless Steel 316L, Aluminium	
	Inner Part	Brass, Brass Nickel Plated, Stainless Steel 316L, Aluminium	
	Seal	CR (Chloroprene) , Silicone	
	O-ring	CR (Chloroprene) , Silicone	
	Spring	Speacial Copper Alloy	
Ingress Protection Rating	IP 68 - 5 Bar, 30 min IP 66		
Operating Temperature	Seal Material		
	CR (Chloroprene)	Silicone	
	Standard	-40°C to +100°C	
LT Type	-40°C to +80°C	-60°C to +80°C	
Equipment For	Gas & Dust potentially explosive atmospheres		
Suitable for use in	Group II	Gas Group IIC ZONE1/ZONE2	
	Group III	Dust Group IIIC ZONE21/ZONE 22	
Equipment Marking	Ex II 2GD Ex db IIC Gb Ex eb IIC Gb Ex tb IIIC Db		
Marking Example *	BMD KBA.. CE 0722 II 2GD Ex db IIC Gb Ex eb IIC Gb Ex tb IIIC Db Ta -60°C to +130°C IP66/68 CESI 13 ATEX 033X IECEx CES 13.0013X		
Thread Type	<ul style="list-style-type: none"> • Metric (M) ISO Pitch 1,5 • NPT (N) ANSI ASME B1.20.1 • Other thread types also available upon request. 		
Cable Type	SWA - AWA		
Accessories	<ul style="list-style-type: none"> • Lock nuts • Gaskets (Washers) • Serrated Washers • Shrouds • Earth tags 		
	<ul style="list-style-type: none"> • O-ring available in Metric outer threads. • Accessories must be ordered separately. 		
	Remarks		
	Approvals	Certificate Number	Standards
		CESI 13 ATEX 033X	EN 60079-0:2012+A11:2013 EN 60079-1:2014 EN 60079-7:2015 EN 60079-31:2014
	IECEx CES 13.0013X	IEC 60079-0:2011 Edition:6 IEC 60079-1:2014 Edition:7 IEC 60079-31:2013 Edition:2 IEC 60079-7:2015-08 Edition:5	
	20150612-E474828	UL 2225, CAN/CSA C-22.2 No. 60079-0:11 CAN/CSA C-22.2 No. 60079-7:12 CAN/CSA-C-22.2 No. 60079-31:12	
	20170315-E199260	UL 514B UL50E	
	№ TC RU C-TR.AA87.B.00941	ГОСТ 31610.0-2014 ГОСТ IEC 60079-1:2013 ГОСТ IEC 60079-31:2013	
	DNV 12.0053 X	ABNT NBR IEC 60079-0:2013, ABNT NBR IEC 60079-1:2009, ABNT NBR IEC 60079-7:2008, ABNT NBR IEC 60079-31:2011	
	E-14044	IEC/EN60079-0, IEC/EN60079-7, IEC/EN60079-31 IEC/EN60079-1, IEC/EN 62444	
	MASC MS/18-0240X	SANS (IEC) 60079-0 : 2011 SANS (IEC) 60079-1 : 2014 SANS (IEC) 60079-7 : 2007 SANS (IEC) 60079-31 : 2014	

-For more information see our webpage.

* The standard marking consists ATEX & IECEx only. Marking acc. to other standards on request.

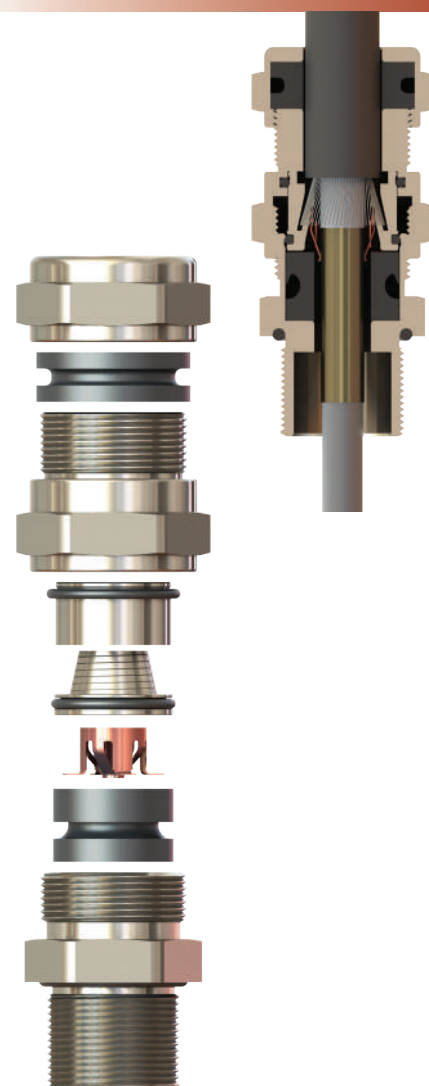

Order Coding								
Part Number	Material	Seal	Lead Sheath	Gasket (Washer)	Serrated Washer	Lock Nut	Shroud	Earth Tag
Mandatory	Mandatory	Mandatory	Mandatory	Option	Option	Option	Option	Option
See table	B Brass BN Brass Nickel plated X Stainless steel A Aluminium	C Chloroprene S Silicone	-	WC Chloroprene WS Silicone WF Fiber	WSR Serrated washer	L Lock nut	S Shroud	E Earth tag
Example								
KBA1N	BN	S	-	LSK	WC	-	L	-

ORION LEAD SHEATHED

Cable Glands for SWA and AWA Cables

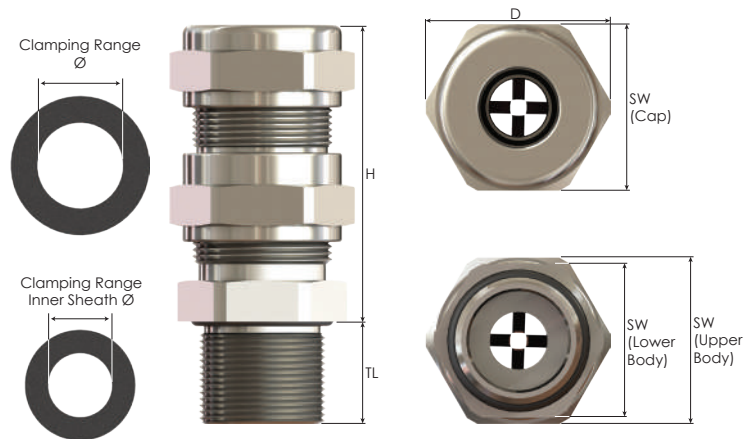

Thread Type METRIC acc. to ISO 965-3

Outer Thread Size (Male)	Clamping Range		Armour Wire Ø min-max mm	Outer Thread Length TL mm	Cap SW Cap mm	Spanner Width Upper Body		Lower Body SW Lower Body mm	Outer Ø D mm	max. Height H mm	Part Number
	Inner Sheath Ø min-max mm	Ø min-max mm				SW Upper Body mm	SW Lower Body mm				
M12x1,5	2,0 - 4,0	3,0 - 5,5	0,10 - 0,40	15,0	17	17	17	17	18,9	62,5	KBA0SM
	3,0 - 7,5	6,0 - 12,0	0,70 - 1,20	15,0	26	26	22	22	29,0	50,5	KBA0SLM
M16x1,5	3,0 - 8,5	6,0 - 12,0	0,70 - 1,20	16,0	26	26	22	22	29,0	49,5	KBA01SM
	6,0 - 12,0	8,5 - 16,0	0,70 - 1,25	16,0	29	29	25	25	31,5	52,0	KBA01M
M20x1,5	3,0 - 8,5	6,0 - 12,0	0,70 - 1,20	16,0	26	26	24	24	29,0	50,0	KBA1SM
	6,0 - 12,0	8,5 - 16,0	0,70 - 1,25	16,0	29	29	25	25	31,5	51,5	KBA1M
	8,5 - 14,5	12,0 - 20,0	0,90 - 1,30	16,0	32	30	28	28	35,0	54,0	KBA1LM
M25x1,5	3,0 - 8,5	6,0 - 12,0	0,70 - 1,20	18,0	26	26	29	29	31,5	50,0	KBA2XSM
	6,0 - 12,0	8,5 - 16,0	0,70 - 1,25	18,0	29	29	29	29	31,5	52,5	KBA2SM
	8,5 - 16,0	12,0 - 21,0	0,70 - 1,20	18,0	34	34	32	32	37,0	56,5	KBA2M
	12,0 - 20,0	16,0 - 26,0	1,30 - 1,70	18,0	40	40	36	36	44,0	63,0	KBA2LM
M32x1,5	6,0 - 12,0	8,5 - 16,0	0,70 - 1,25	18,0	29	29	36	36	39,8	52,5	KBA3XSM
	12,0 - 20,0	16,0 - 26,0	1,30 - 1,70	18,0	40	40	40	40	44,0	64,0	KBA3SM
	15,0 - 26,0	20,0 - 33,0	1,20 - 1,80	18,0	52	52	48	48	57,0	81,0	KBA3M
M40x1,5	12,0 - 20,0	16,0 - 26,0	1,30 - 1,70	18,0	40	40	45	45	50,0	64,0	KBA4XSM
	15,0 - 26,0	20,0 - 33,0	1,20 - 1,80	18,0	52	52	48	48	57,0	81,0	KBA4SM
	20,0 - 32,0	29,0 - 41,0	1,60 - 2,20	18,0	60	60	55	55	66,0	92,0	KBA4M
M50x1,5	15,0 - 26,0	20,0 - 33,0	1,20 - 1,80	18,0	52	52	54	54	60,0	81,0	KBA5XSM
	20,0 - 32,0	29,0 - 41,0	1,60 - 2,20	18,0	60	60	55	55	66,0	92,0	KBA5XMM
	22,0 - 35,0	33,0 - 48,0	2,00 - 2,80	18,0	75	70	60	60	83,0	100,0	KBA5SM
	27,0 - 41,0	36,0 - 52,0	1,80 - 2,80	18,0	74	70	70	70	81,8	104,5	KBA5M
M63x1,5	22,0 - 35,0	33,0 - 48,0	2,00 - 2,80	20,0	75	70	68	68	83,0	100,0	KBA6XSM
	27,0 - 41,0	36,0 - 52,0	1,80 - 2,80	20,0	74	70	70	70	81,8	104,5	KBA6XMM
	35,0 - 45,0	43,0 - 57,0	1,80 - 2,80	20,0	80	80	75	75	89,5	109,5	KBA6SM
	40,0 - 52,0	47,0 - 60,0	1,80 - 2,80	20,0	85	85	85	85	94,0	111,5	KBA6M
M75x1,5	45,0 - 56,0	54,0 - 70,0	1,30 - 2,50	20,0	100	95	90	90	110,5	128,5	KBA6LM
	35,0 - 45,0	43,0 - 57,0	1,80 - 2,80	20,0	80	80	85	85	94,0	109,5	KBA7XSM
	40,0 - 52,0	47,0 - 60,0	1,80 - 2,80	20,0	85	85	85	85	94,0	111,5	KBA7SM
M90x1,5	45,0 - 60,0	54,0 - 70,0	1,00 - 2,30	20,0	100	95	90	90	110,5	127,5	KBA7M
	40,0 - 52,0	47,0 - 60,0	1,80 - 2,80	20,0	85	85	100	100	110,5	111,5	KBA8XSM
	45,0 - 60,0	54,0 - 70,0	1,00 - 2,30	20,0	100	95	95	95	110,5	127,5	KBA8SM
M110x1,5	60,0 - 72,0	63,0 - 80,0	1,00 - 3,50	20,0	115	115	110	110	127,0	158,0	KBA8M
	45,0 - 60,0	54,0 - 70,0	1,00 - 2,30	20,0	100	95	120	120	128,0	127,5	KBA10SM
	60,0 - 72,0	63,0 - 80,0	1,00 - 3,50	20,0	115	115	120	120	128,0	158,0	KBA10M









Thread Type METRIC acc. to ISO 965-3 (LT Type)

Outer Thread Size (Male)	Clamping Range		Armour Wire Ø min-max mm	Outer Thread Length TL mm	Cap SW Cap mm	Spanner Width Upper Body		Lower Body SW Lower Body mm	Outer Ø D mm	max. Height H mm	Part Number
	Inner Sheath Ø min-max mm	Ø min-max mm				SW Upper Body mm	SW Lower Body mm				
M90x2,0	70,0 - 82,0	78,0 - 90,0	1,5 - 4,4	20,0	120	120	120	120	134,0	159,5	KBA8MLT
M100x2,0	80,0 - 92,0	88,0 - 100,0	1,2 - 4,0	20,0	135	135	135	135	150,0	169,0	KBA9SMLT
M110x2,0	90,0 - 101,0	98,0 - 110,0	2,1 - 5,4	20,0	145	145	145	145	162,0	180,0	KBA10MLT
M130x2,0	100,0 - 115,0	109,0 - 123,0	2,0 - 5,4	24,0	160	160	160	160	176,0	202,0	KBA13MLT

Cable Glands for SWA and AWA Cables

ORION LEAD SHEATHED



Technical Details	
Body, Cap	Brass, Brass Nickel Plated, Stainless Steel 316L, Aluminium
Material	Brass, Brass Nickel Plated, Stainless Steel 316L, Aluminium
Seal	CR (Chloroprene) , Silicone
O-ring	CR (Chloroprene) , Silicone
Spring	Special Copper Alloy
Ingress Protection Rating	IP 68 - 5 Bar, 30 min IP 66
Operating Temperature	Seal Material
Standard	CR (Chloroprene)
LT Type	Silicone
Equipment For	Gas & Dust potentially explosive atmospheres
Suitable for use in	Group II Gas Group IIC ZONE1 /ZONE2 Group III Dust Group IIIC ZONE21 /ZONE 22
Equipment Marking	Ex II 2GD Ex db IIC Gb Ex eb IIC Gb Ex tb IIIC Db
Marking Example *	BMD KBA.. CE 0722  II 2GD Ex db IIC Gb Ex eb IIC Gb Ex tb IIIC Db Ta -60°C to +130°C IP66/68 CESI 13 ATEX 033X IECEx CES 13.0013X
Thread Type	<ul style="list-style-type: none"> • Metric (M) ISO Pitch 1,5 • NPT (N) ANSI ASME B1.20.1 • Other thread types also available upon request.
Cable Type	SWA - AWA
Accessories	<ul style="list-style-type: none"> • Lock nuts • Gaskets (Washers) • Serrated Washers • Shrouds • Earth tags
Remarks	<ul style="list-style-type: none"> • O-ring available in Metric outer threads. • Accessories must be ordered separately.
Approvals	Certificate Number
	CESI 13 ATEX 033X
	IECEx CES 13.0013X
	20150612-E474828 20170315-E199260
	№ TC RU C-TR.AA87.B.00941
	DNV 12.0053 X
	E-14044
	MASC MS/18-0240X
	Standards
	EN 60079-0:2012+A11:2013 EN 60079-1:2014 EN 60079-7:2015 EN 60079-31:2014
	IEC 60079-0:2011 Edition:6 IEC 60079-1:2014 Edition:7 IEC 60079-31:2013 Edition:2 IEC 60079-7:2015-08 Edition:5
	UL 2225, CAN/CSA-C22.2 No. 60079-0:11 CAN/CSA C22.2 No. 60079-7:12 CAN/CSA-C22.2 No. 60079-31:12
	UL 514B UL50E
	ГОСТ 31610.0-2014 ГОСТ IEC 60079-1:2013 ГОСТ IEC 60079-31:2013
	ABNT NBR IEC 60079-0:2013, ABNT NBR IEC 60079-1:2009, ABNT NBR IEC 60079-7:2008, ABNT NBR IEC 60079-31:2011
	IEC/EN60079-0, IEC/EN60079-7, IEC/EN60079-31 IEC/EN60079-1, IEC/EN 62444
	SANS (IEC) 60079-0 : 2011 SANS (IEC) 60079-1 : 2014 SANS (IEC) 60079-7 : 2007 SANS (IEC) 60079-31 : 2014

-For more information see our webpage.

* The standard marking consists ATEX & IECEx only. Marking acc. to other standards on request.



Order Coding

Part Number	Material	Seal	Lead Sheath	Gasket (Washer)	Serrated Washer	Lock Nut	Shroud	Earth Tag
Mandatory	Mandatory	Mandatory	Mandatory	Option	Option	Option	Option	Option
See table	B Brass BN Brass Nickel plated X Stainless steel A Aluminium	C Chloroprene S Silicone	-	WC Chloroprene WS Silicone WF Fiber	WSR Serrated washer	L Lock nut	S Shroud	E Earth tag

Example

KBA1N	BN	S	-	LSK	WC	-	L	-	E
-------	----	---	---	-----	----	---	---	---	---

ORION LEAD SHEATHED

Cable Glands for SWA and AWA Cables

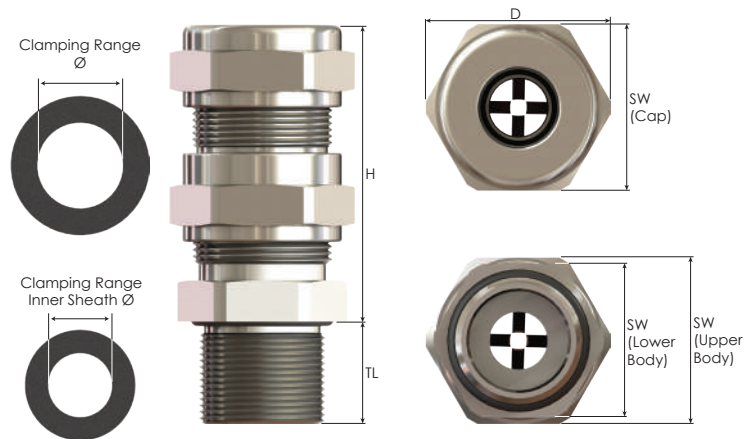

Thread Type **NPT** acc. to ANSI ASME B1.20.1

Outer Thread Size (Male)	Clamping Range		Armour Wire Ø min-max mm	Outer Thread Length TL mm	Cap SW Cap mm	Spanner Width		Outer Ø mm	max. Height H mm	Part Number
	Inner Sheath Ø min-max mm	Ø min-max mm				Upper Body SW Upper Body mm	Lower Body SW Lower Body mm			
NPT 1/4"	2,0 - 4,0	3,0 - 5,5	0,10 - 0,40	15,0	17	17	17	18,9	62,5	KBA0SN
	3,0 - 8,0	6,0 - 12,0	0,70 - 1,20	15,0	26	26	22	29,0	50,0	KBA0SLN
NPT 3/8"	3,0 - 8,5	6,0 - 12,0	0,70 - 1,20	16,0	26	26	22	29,0	49,5	KBA01SN
	6,0 - 12,0	8,5 - 16,0	0,70 - 1,25	16,0	29	29	25	31,5	52,0	KBA01N
NPT 1/2"	3,0 - 8,5	6,0 - 12,0	0,70 - 1,20	21,0	26	26	24	29,0	49,5	KBA1SN
	6,0 - 12,0	8,5 - 16,0	0,70 - 1,25	21,0	29	29	25	31,5	51,0	KBA1N
	8,5 - 14,5	12,0 - 20,0	0,90 - 1,30	21,0	32	30	28	35,0	54,0	KBA1LN
NPT 3/4"	3,0 - 8,5	6,0 - 12,0	0,70 - 1,20	21,0	26	26	29	31,5	50,0	KBA2XSN
	6,0 - 12,0	8,5 - 16,0	0,70 - 1,25	21,0	29	29	29	31,5	52,5	KBA2SN
	8,5 - 16,0	12,0 - 21,0	0,70 - 1,20	21,0	34	34	32	37,0	56,5	KBA2N
	12,0 - 20,0	16,0 - 26,0	1,30 - 1,70	21,0	40	40	36	44,0	62,5	KBA2LN
NPT 1"	6,0 - 12,0	8,5 - 16,0	0,70 - 1,25	26,0	29	29	36	39,8	52,5	KBA3XSN
	12,0 - 20,0	16,0 - 26,0	1,30 - 1,70	26,0	40	40	40	44,0	64,0	KBA3SN
	15,0 - 26,0	20,0 - 33,0	1,20 - 1,80	26,0	52	52	48	57,0	80,5	KBA3N
NPT 1 1/4"	12,0 - 20,0	16,0 - 26,0	1,30 - 1,70	28,0	40	40	45	50,0	64,0	KBA4XSN
	15,0 - 26,0	20,0 - 33,0	1,20 - 1,80	28,0	52	52	48	57,0	81,0	KBA4SN
	20,0 - 32,0	29,0 - 41,0	1,60 - 2,20	28,0	60	60	55	66,0	92,0	KBA4N
NPT 1 1/2"	15,0 - 26,0	20,0 - 33,0	1,20 - 1,80	28,0	52	52	54	60,0	81,0	KBA5XSN
	20,0 - 32,0	29,0 - 41,0	1,60 - 2,20	28,0	60	60	55	66,0	92,0	KBA5XMN
	22,0 - 35,0	33,0 - 48,0	2,00 - 2,80	28,0	75	70	60	83,0	100,0	KBA5SN
	27,0 - 41,0	36,0 - 52,0	1,80 - 2,80	28,0	74	70	70	81,8	104,5	KBA5N
NPT 2"	22,0 - 35,0	33,0 - 48,0	2,00 - 2,80	28,0	75	70	68	83,0	100,0	KBA6XSN
	27,0 - 41,0	36,0 - 52,0	1,80 - 2,80	28,0	74	70	70	81,8	104,5	KBA6XMN
	35,0 - 45,0	43,0 - 57,0	1,80 - 2,80	28,0	80	80	75	89,5	109,5	KBA6SN
	40,0 - 52,0	47,0 - 60,0	1,80 - 2,80	28,0	85	85	85	94,0	111,5	KBA6N
NPT 2 1/2"	45,0 - 52,0	54,0 - 70,0	1,30 - 2,50	28,0	100	95	90	110,5	128,5	KBA6LN
	35,0 - 45,0	43,0 - 57,0	1,80 - 2,80	41,0	80	80	80	89,5	109,0	KBA7XSN
	40,0 - 52,0	47,0 - 60,0	1,80 - 2,80	41,0	85	85	85	94,0	111,5	KBA7SN
NPT 3"	45,0 - 60,0	54,0 - 70,0	1,00 - 2,30	41,0	100	95	90	110,5	127,5	KBA7LN
	40,0 - 52,0	47,0 - 60,0	1,80 - 2,80	43,0	85	85	95	105,0	111,5	KBA8XSN
	60,0 - 72,0	63,0 - 80,0	1,00 - 3,50	43,0	115	115	110	127,0	158,0	KBA8SN
NPT 3 1/2"	45,0 - 60,0	54,0 - 70,0	1,00 - 2,30	45,0	100	95	110	123,0	127,5	KBA9SN
	60,0 - 72,0	63,0 - 80,0	1,00 - 3,50	45,0	115	115	110	127,0	158,0	KBA9N

Thread Type **NPT** acc. to ANSI ASME B1.20.1 (LT Type)

Outer Thread Size (Male)	Clamping Range		Armour Wire Ø min-max mm	Outer Thread Length TL mm	Cap SW Cap mm	Spanner Width		Outer Ø mm	max. Height H mm	Part Number
	Inner Sheath Ø min-max mm	Ø min-max mm				Upper Body SW Upper Body mm	Lower Body SW Lower Body mm			
NPT 3 1/2"	70,0 - 82,0	78,0 - 90,0	1,5 - 4,4	45,0	120	120	120	134,0	159,5	KBA9MNL
NPT 4"	80,0 - 92,0	88,0 - 100,0	1,2 - 4,0	46,0	135	135	135	150,0	169,0	KBA10SNLT
	90,0 - 101,0	98,0 - 110,0	2,1 - 5,4	46,0	145	145	145	162,0	180,0	KBA10NLT
NPT 5"	100,0 - 115,0	109,0 - 123,0	2,0 - 5,4	48,0	160	160	160	176,0	202,0	KBA11SNLT

Diaphragm Sealed Glands for All Types of Armoured Cables

CORONA UNIVERSAL



Technical Details			
Material	Body, Cap	Brass, Brass Nickel Plated, Stainless Steel 316L	
	Inner Part	Brass, Brass Nickel Plated, Stainless Steel 316L	
	Seal	Silicone	
	O-ring	Silicone	
	Lower Insert	PA 6 (Polyamide 6)	
Ingress Protection Rating	IP 68 - 5 Bar, 30 min IP 66		
Operating Temperature	Seal Material	Silicone	
		-40°C to +80°C	
Equipment For	Gas & Dust potentially explosive atmospheres		
Suitable for use in	Group II	Gas Group IIC	ZONE1/ZONE2
	Group III	Dust Group IIIC	ZONE21/ZONE 22
Equipment Marking	Group II/III Ex II 2GD Ex db IIC Gb Ex eb IIC Gb Ex tb IIC Db		
Marking Example *	BMD KBCU.. CE 0722 II 2GD Ex db IIC Gb Ex eb IIC Gb Ex tb IIC Db IP66/68 Ta -40°C to +80°C		
Thread Type	• Metric (M) ISO Pitch 1,5		
	• NPT (N) ANSI ASME B1.20.1		
	• Other thread types also available upon request.		
Cable Type	SWA - SWB - STA - PWA - AWA - Shielded		
Accessories	• Lock nuts		
	• Gaskets (Washers)		
	• Serrated Washers		
	• Shrouds		
	• Earth tags		
Remarks	• Gasket available in Metric threads. For NPT threads gasket must be ordered separately.		
	• Accessories must be ordered separately.		
Approvals	Certificate Number	Standards	
	CESI 13 ATEX 033X	EN 60079-0:2012+A11:2013 EN 60079-1:2014 EN 60079-7:2015 EN 60079-31:2014	
		IECEX CES 17.0042X	IEC 60079-0:2011 Edition:6 IEC 60079-1:2014 Edition:7 IEC 60079-31:2013 Edition:2 IEC 60079-7:2015-08 Edition:5
		№ TC RU C-TR.AA87.B.00941	ГОСТ 31610.0-2014 ГОСТ IEC 60079-1:2013 ГОСТ IEC 60079-31:2013
-For more information see our webpage.			
* The standard marking consists ATEX & IECEx only. Marking acc. to other standards on request.			

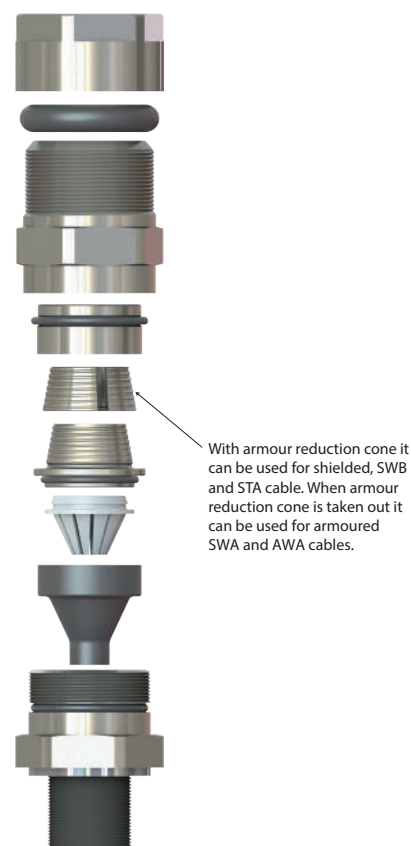

Order Coding							
Part Number	Material	Seal	- Gasket (Washer)	Serrated Washer	Lock Nut	Shroud	Earth Tag
Mandatory	Mandatory	Mandatory	- Option	Option	Option	Option	Option
See table	B Brass BN Brass Nickel plated X Stainless steel 316L	S Silicone	- WS Silicone	WSR Serrated washer	L Lock nut	S Shroud	E Earth tag
Example							
KBCU4N	BN	S	- WS	WSR	L	S	E

CORONA UNIVERSAL

Diaphragm Sealed Glands for All Types of Armoured Cables

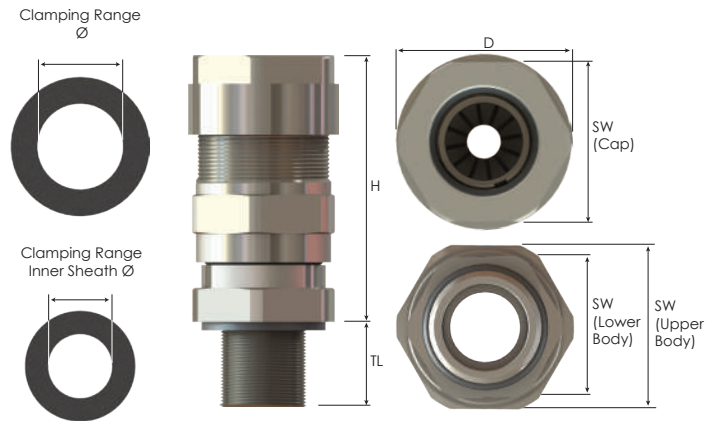

Thread Type **METRIC** acc. to ISO 965 - 3

Outer Thread Size (Male)	Clamping Range		Armour Wire Ø min-max mm	Shield Wire Ø min-max mm	Outer Thread Length TL mm	Cap SW Cap mm	Spanner Width Upper Body SW Upper Body mm	Lower Body SW Lower Body mm	Outer Ø		Part Number
	Inner Sheath Ø min-max mm	Ø min-max mm							D mm	H mm	
M16x1,5	6,0 - 11,0	9,0 - 16,0	0,8 - 1,25	0,2 - 0,8	15,0	24	24	24	27,5	45,0	KBCU01M
M20x1,5	6,0 - 11,0	9,0 - 16,0	0,8 - 1,25	0,2 - 0,8	15,0	24	24	24	27,5	45,0	KBCU1SM
	8,5 - 14,5	12,0 - 20,0	0,8 - 1,25	0,2 - 0,8	15,0	30	30	29	33,0	48,0	KBCU1M
M25x1,5	8,5 - 14,5	12,0 - 20,0	0,8 - 1,25	0,2 - 0,8	15,0	30	30	36	40,0	48,0	KBCU2SM
	12,0 - 20,0	16,0 - 26,0	1,25 - 1,6	0,2 - 0,7	15,0	36	36	36	40,0	54,0	KBCU2M
M32x1,5	12,0 - 20,0	16,0 - 26,0	1,25 - 1,6	0,2 - 0,7	15,0	36	36	44	52,5	54,0	KBCU3SM
	17,0 - 26,0	20,0 - 33,0	1,6 - 2,0	0,2 - 0,7	15,0	46	46	44	52,5	64,5	KBCU3M
M40x1,5	17,0 - 26,0	20,0 - 33,0	1,6 - 2,0	0,2 - 0,7	15,0	46	46	55	64,0	64,5	KBCU4SM
	23,0 - 32,0	29,0 - 41,0	1,6 - 2,0	0,2 - 0,7	15,0	55	55	55	64,0	67,0	KBCU4M
M50x1,5	23,0 - 32,0	29,0 - 41,0	1,6 - 2,0	0,2 - 0,7	15,0	55	55	65	74,0	67,0	KBCU5SM
	29,0 - 41,0	36,0 - 52,0	1,8 - 2,5	0,2 - 1,0	15,0	65	65	65	74,0	77,7	KBCU5M
M63x1,5	29,0 - 41,0	36,0 - 52,0	1,8 - 2,5	0,2 - 1,0	15,0	65	65	80	92,0	77,7	KBCU6SM
	44,0 - 56,0	50,0 - 65,0	1,8 - 2,5	0,2 - 1,0	15,0	80	80	80	92,0	90,7	KBCU6M
M75x1,5	44,0 - 56,0	50,0 - 65,0	1,8 - 2,5	0,2 - 1,0	15,0	80	80	95	107,5	90,7	KBCU7SM
	54,5 - 68,0	61,0 - 78,0	1,8 - 2,5	0,2 - 1,0	15,0	95	95	95	107,5	103,7	KBCU7M
M80x1,5	54,5 - 68,0	61,0 - 78,0	1,8 - 2,5	0,2 - 1,0	15,0	95	95	95	118,0	103,7	KBCU80SM
	67,0 - 73,0	75,0 - 89,0	2,0 - 3,5	0,2 - 1,0	15,0	106	106	106	118,0	100,2	KBCU80M
M90x1,5	67,0 - 77,0	75,0 - 89,0	2,0 - 3,5	0,2 - 1,0	15,0	115	115	115	133,0	100,0	KBCU8M
M100x1,5	75,0 - 91,0	88,0 - 104,0	2,5 - 4,0	0,2 - 1,0	15,0	127	127	127	145,0	114,0	KBCU9M

Diaphragm Sealed Glands for All Types of Armoured Cables

CORONA UNIVERSAL

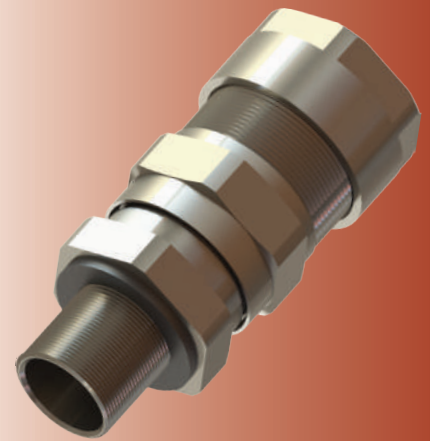

Technical Details		
Body, Cap	Brass, Brass Nickel Plated, Stainless Steel 316L	
Inner Part	Brass, Brass Nickel Plated, Stainless Steel 316L	
Material	Seal	
	O-ring	
	Lower Insert	
Ingress Protection Rating	IP 68 - 5 Bar, 30 min IP 66	
Operating Temperature	Seal Material	
	Silicone -40°C to +80°C	
Equipment For	Gas & Dust potentially explosive atmospheres	
Suitable for use in	Group II Gas Group IIC ZONE1/ZONE2	
	Group III Dust Group IIIC ZONE21/ZONE 22	
Equipment Marking	Group II/III Ex II 2GD Ex db IIC Gb Ex eb IIC Gb Ex tb IIC Db	
Marking Example *	BMD KBCU.. CE 0722 II 2GD Ex db IIC Gb Ex eb IIC Gb Ex tb IIC Db IP66/68 Ta -40°C to +80°C	
Thread Type	<ul style="list-style-type: none"> • Metric (M) ISO Pitch 1,5 • NPT (N) ANSI ASME B1.20.1 • Other thread types also available upon request. 	
Cable Type	SWA - SWB - STA - PWA - AWA - Shielded	
Accessories	<ul style="list-style-type: none"> • Lock nuts • Gaskets (Washers) • Serrated Washers • Shrouds • Earth tags 	
Remarks	<ul style="list-style-type: none"> • Gasket available in Metric threads. For NPT threads gasket must be ordered separately. • Accessories must be ordered separately. 	
Approvals	Certificate Number	Standards
	CESI 13 ATEX 033X	EN 60079-0:2012+A11:2013 EN 60079-1:2014 EN 60079-7:2015 EN 60079-31:2014
	IECEx CES 17.0042X	IEC 60079-0:2011 Edition:6 IEC 60079-1:2014 Edition:7 IEC 60079-31:2013 Edition:2 IEC 60079-7:2015-08 Edition:5
	№ TC RU C-TR.AA87.B.00941	ГОСТ 31610.0-2014 ГОСТ IEC 60079-1:2013 ГОСТ IEC 60079-31:2013
-For more information see our webpage.		
* The standard marking consists ATEX & IECEx only. Marking acc. to other standards on request.		



With armour reduction cone it can be used for shielded, SWB and STA cable. When armour reduction cone is taken out it can be used for armoured SWA and AWA cables.

Order Coding								
Part Number	Material	Seal	-	Gasket (Washer)	Serrated Washer	Lock Nut	Shroud	Earth Tag
Mandatory	Mandatory	Mandatory	-	Option	Option	Option	Option	Option
See table	B Brass BN Brass, Nickel plated X Stainless steel 316L	S Silicone	-	WS Silicone	WSR Serrated washer	L Lock nut	S Shroud	E Earth tag
Example								
KBCU4N	BN	S	-	WS	WSR	L	S	E

CORONA UNIVERSAL

Diaphragm Sealed Glands for All Types of Armoured Cables

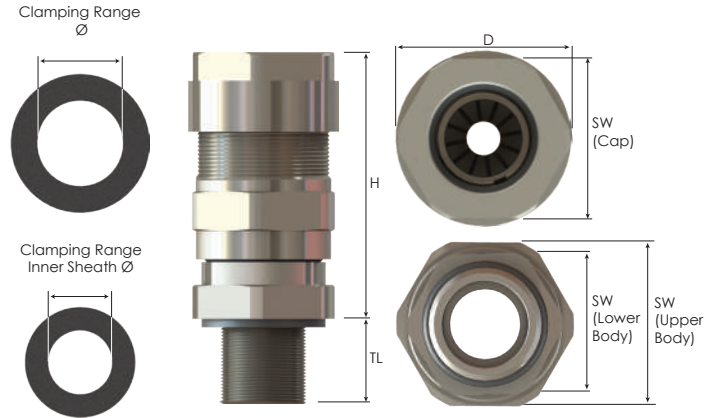





Thread Type **NPT** acc. to ANSI ASME B1.20.1

Outer Thread Size (Male)	Clamping Range		Armour Wire	Shield Wire	Outer Thread Length	Cap	Spanner Width Upper Body	Lower Body	Outer Ø	max. Height	Part Number
	Inner Sheath Ø min-max mm	Ø min-max mm	Ø min-max mm	Ø min-max mm							
NPT 3/8"	6,0 - 11,0	9,0 - 16,0	0,8 - 1,25	0,2 - 0,8	15,5	24	24	24	27,5	45,0	KBCU01N
NPT 1/2"	6,0 - 11,0	9,0 - 16,0	0,8 - 1,25	0,2 - 0,8	20,1	24	24	24	27,5	45,0	KBCU1SN
	8,5 - 14,5	12,0 - 20,0	0,8 - 1,25	0,2 - 0,8	20,1	30	30	29	33,0	48,0	KBCU1N
NPT 3/4"	8,5 - 14,5	12,0 - 20,0	0,8 - 1,25	0,2 - 0,8	20,4	30	30	36	40,0	48,0	KBCU2SN
	12,0 - 20,0	16,0 - 26,0	1,25 - 1,6	0,2 - 0,7	20,4	36	36	36	40,0	54,0	KBCU2N
NPT 1"	12,0 - 20,0	16,0 - 26,0	1,25 - 1,6	0,2 - 0,7	25,5	36	36	44	52,5	54,0	KBCU3SN
	17,0 - 26,0	20,0 - 33,0	1,6 - 2,0	0,2 - 0,7	25,5	46	46	44	52,5	64,5	KBCU3N
NPT 1 1/4"	17,0 - 26,0	20,0 - 33,0	1,6 - 2,0	0,2 - 0,7	26,1	46	46	55	64,0	64,5	KBCU4SN
	23,0 - 32,0	29,0 - 41,0	1,6 - 2,0	0,2 - 0,7	26,1	55	55	55	64,0	67,0	KBCU4N
NPT 1 1/2"	23,0 - 32,0	29,0 - 41,0	1,6 - 2,0	0,2 - 0,7	26,5	55	55	65	74,0	67,0	KBCU5SN
	29,0 - 39,0	36,0 - 52,0	1,8 - 2,5	0,2 - 1,0	26,5	65	65	65	74,0	77,7	KBCU5N
NPT 2"	29,0 - 41,0	36,0 - 52,0	1,8 - 2,5	0,2 - 1,0	27,4	65	65	80	92,0	77,7	KBCU6SN
	44,0 - 52,0	50,0 - 65,0	1,8 - 2,5	0,2 - 1,0	27,4	80	80	80	92,0	90,7	KBCU6N
NPT 2 1/2"	44,0 - 56,0	50,0 - 65,0	1,8 - 2,5	0,2 - 1,0	40,4	80	80	95	107,5	90,7	KBCU7SN
	54,5 - 63,0	61,0 - 78,0	1,8 - 2,5	0,2 - 1,0	40,4	95	95	95	107,5	103,7	KBCU7N
NPT 3"	54,5 - 68,0	61,0 - 78,0	1,8 - 2,5	0,2 - 1,0	41,9	95	95	95	118,0	103,7	KBCU80SN
	67,0 - 73,0	75,0 - 89,0	2,0 - 3,5	0,2 - 1,0	41,9	106	106	106	118,0	100,2	KBCU80N
NPT 3 1/2"	67,0 - 77,0	75,0 - 89,0	2,0 - 3,5	0,2 - 1,0	43,2	115	115	115	133,0	100,0	KBCU8N
NPT 4"	75,0 - 91,0	88,0 - 104,0	2,5 - 4,0	0,2 - 1,0	44,5	127	127	127	145,0	114,0	KBCU9N

Diaphragm Sealed Glands for SWA, STA and Shielded Cables

CORONA OFFSHORE



Technical Details			
Body, Cap	Brass, Brass Nickel Plated, Stainless Steel 316L		
Inner Part	Brass, Brass Nickel Plated, Stainless Steel 316L		
Material	Seal	Silicone	
	O-ring	Silicone	
	Lower Insert	PA 6 (Polyamide 6)	
Ingress Protection Rating	IP 68 - 5 Bar, 30 min IP 66		
Operating Temperature	Seal Material	Silicone	
		-40°C to +80°C	
Equipment For	Gas & Dust potentially explosive atmospheres		
Suitable for use in	Group II	Gas Group IIC	ZONE1/ZONE2
	Group III	Dust Group IIIC	ZONE21/ZONE 22
Equipment Marking	Group II/III Ex II 2GD Ex db IIC Gb Ex eb IIC Gb Ex tb IIIC Db		
Marking Example *	BMD KBCO.. CE 0722  II 2GD Ex db IIC Gb Ex eb IIC Gb Ex tb IIIC Db IP66/68 Ta -40°C to +80°C		
Thread Type	<ul style="list-style-type: none"> • Metric (M) ISO Pitch 1,5 • NPT (N) ANSI ASME B1.20.1 • Other thread types also available upon request. 		
Cable Type	SWA - AWA		
Accessories	• Lock nuts		
	• Gaskets (Washers)		
	• Serrated Washers		
	• Shrouds		
	• Earth tags		
Remarks	<ul style="list-style-type: none"> • Gasket available in Metric threads. For NPT threads gasket must be ordered separately. • Accessories must be ordered separately. 		
Approvals	Certificate Number	Standards	
	CESI 13 ATEX 033X	EN 60079-0:2012+A11:2013 EN 60079-1:2014 EN 60079-7:2015 EN 60079-31:2014	
	IECEx CES 17.0042X	IEC 60079-0:2011 Edition:6 IEC 60079-1:2014 Edition:7 IEC 60079-31:2013 Edition:2 IEC 60079-7:2015-08 Edition:5	
	№ TC RU C-TR.AA87.B.00941	ГОСТ 31610.0-2014 ГОСТ IEC 60079-1:2013 ГОСТ IEC 60079-31:2013	
-For more information see our webpage.			
* The standard marking consists ATEX & IECEx only. Marking acc. to other standards on request.			



Order Coding								
Part Number	Material	Seal	-	Gasket (Washer)	Serrated Washer	Lock Nut	Shroud	Earth Tag
Mandatory	Mandatory	Mandatory	-	Option	Option	Option	Option	Option
See table	B Brass BN Brass Nickel plated X Stainless steel 316L	S Silicone	-	WS Silicone	WSR Serrated washer	L Lock nut	S Shroud	E Earth tag
Example								
KBCO4N	BN	S	-	WS	WSR	L	S	E

CORONA OFFSHORE

Diaphragm Sealed Glands for SWA, STA and Shielded Cables

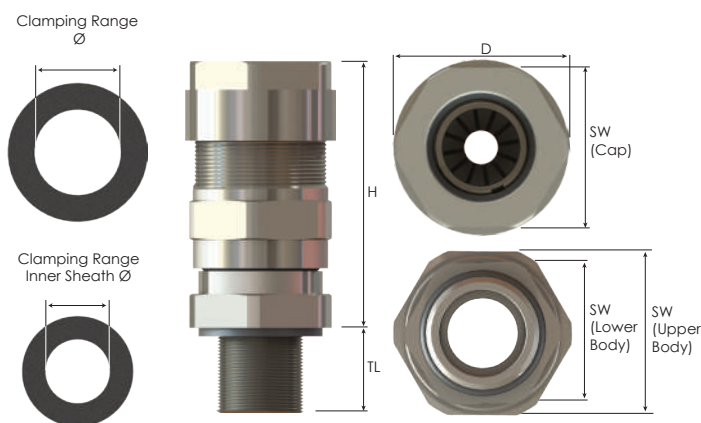





Thread Type METRIC acc. to ISO 965 - 3										
Outer Thread Size (Male)	Clamping Range		Shield Wire Ø min-max mm	Outer Thread Length TL mm	Spanner Width			Outer Ø D mm	max. Height H mm	Part Number
	Inner Sheath Ø min-max mm	Ø min-max mm			Cap SW Cap mm	Upper Body SW Upper Body mm	Lower Body SW Lower Body mm			
M16x1,5	6,0 - 11,0	9,0 - 16,0	0,2 - 0,8	15,0	24	24	24	27,5	45,0	KBCO01M
M20x1,5	6,0 - 11,0	9,0 - 16,0	0,2 - 0,8	15,0	24	24	24	27,5	45,0	KBCO1SM
	8,5 - 14,5	12,0 - 20,0	0,2 - 0,8	15,0	30	30	29	33,0	48,0	KBCO1M
M25x1,5	8,5 - 14,5	12,0 - 20,0	0,2 - 0,8	15,0	30	30	36	40,0	48,0	KBCO2SM
	12,0 - 20,0	16,0 - 26,0	0,2 - 0,7	15,0	36	36	36	40,0	54,0	KBCO2M
M32x1,5	12,0 - 20,0	16,0 - 26,0	0,2 - 0,7	15,0	36	36	44	52,5	54,0	KBCO3SM
	17,0 - 26,0	20,0 - 33,0	0,2 - 0,7	15,0	46	46	44	52,5	64,5	KBCO3M
M40x1,5	17,0 - 26,0	20,0 - 33,0	0,2 - 0,7	15,0	46	46	55	64,0	64,5	KBCO4SM
	23,0 - 32,0	29,0 - 41,0	0,2 - 0,7	15,0	55	55	55	64,0	67,0	KBCO4M
M50x1,5	23,0 - 32,0	29,0 - 41,0	0,2 - 0,7	15,0	55	55	65	74,0	67,0	KBCO5SM
	29,0 - 41,0	36,0 - 52,0	0,2 - 1,0	15,0	65	65	65	74,0	77,7	KBCO5M
M63x1,5	29,0 - 41,0	36,0 - 52,0	0,2 - 1,0	15,0	65	65	80	92,0	77,7	KBCO6SM
	44,0 - 56,0	50,0 - 65,0	0,2 - 1,0	15,0	80	80	80	92,0	90,7	KBCO6M
M75x1,5	44,0 - 56,0	50,0 - 65,0	0,2 - 1,0	15,0	80	80	95	107,5	90,7	KBCO7SM
	54,5 - 68,0	61,0 - 78,0	0,2 - 1,0	15,0	95	95	95	107,5	103,7	KBCO7M
M80x1,5	54,5 - 68,0	61,0 - 78,0	0,2 - 1,0	15,0	95	95	95	118,0	103,7	KBCO80SM
	67,0 - 73,0	75,0 - 89,0	0,2 - 1,0	15,0	106	106	106	118,0	100,2	KBCO80M
M90x1,5	67,0 - 77,0	75,0 - 89,0	0,2 - 1,0	15,0	115	115	115	133,0	100,0	KBCO8M
M100x1,5	75,0 - 91,0	88,0 - 104,0	0,2 - 1,0	15,0	127	127	127	145,0	114,0	KBCO9M

Diaphragm Sealed Glands for SWA, STA and Shielded Cables

CORONA OFFSHORE



Technical Details			
Body, Cap	Brass, Brass Nickel Plated, Stainless Steel 316L		
Inner Part	Brass, Brass Nickel Plated, Stainless Steel 316L		
Material	Seal	Silicone	
	O-ring	Silicone	
	Lower Insert	PA 6 (Polyamide 6)	
Ingress Protection Rating	IP 68 - 5 Bar, 30 min IP 66		
Operating Temperature	Seal Material	Silicone	
		-40°C to +80°C	
Equipment For	Gas & Dust potentially explosive atmospheres		
Suitable for use in	Group II	Gas Group IIC	ZONE1/ZONE2
	Group III	Dust Group IIIC	ZONE21/ZONE 22
Equipment Marking	Group II/III Ex II 2GD Ex db IIC Gb Ex eb IIC Gb Ex tb IIIC Db		
Marking Example *	BMD KBCO.. CE 0722  II 2GD Ex db IIC Gb Ex eb IIC Gb Ex tb IIIC Db IP66/68 Ta -40°C to +80°C		
Thread Type	<ul style="list-style-type: none"> • Metric (M) ISO Pitch 1,5 • NPT (N) ANSI ASME B1.20.1 • Other thread types also available upon request. 		
Cable Type	SWA - AWA		
Accessories	• Lock nuts		
	• Gaskets (Washers)		
	• Serrated Washers		
	• Shrouds		
	• Earth tags		
Remarks	• Gasket available in Metric threads. For NPT threads gasket must be ordered separately.		
	• Accessories must be ordered separately.		
Approvals	Certificate Number	Standards	
	CESI 13 ATEX 033X	EN 60079-0:2012+A11:2013 EN 60079-1:2014 EN 60079-7:2015 EN 60079-31:2014	
	IECEx CES 17.0042X	IEC 60079-0:2011 Edition:6 IEC 60079-1:2014 Edition:7 IEC 60079-31:2013 Edition:2 IEC 60079-7:2015-08 Edition:5	
	№ TC RU C-TR.AA87.B.00941	ГОСТ 31610.0-2014 ГОСТ IEC 60079-1:2013 ГОСТ IEC 60079-31:2013	

-For more information see our webpage.

* The standard marking consists ATEX & IECEx only. Marking acc. to other standards on request.



Order Coding							
Part Number	Material	Seal	- Gasket (Washer)	Serrated Washer	Lock Nut	Shroud	Earth Tag
Mandatory	Mandatory	Mandatory	- Option	Option	Option	Option	Option
See table	B Brass BN Brass Nickel plated X Stainless steel 316L	S Silicone	- WS Silicone	WSR Serrated washer	L Lock nut	S Shroud	E Earth tag
Example							
KBCO4N	BN	S	- WS	WSR	L	S	E

CORONA OFFSHORE

Diaphragm Sealed Glands for SWA, STA and Shielded Cables

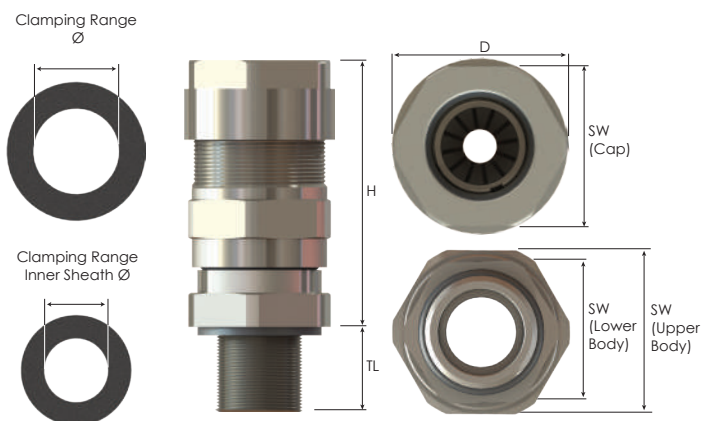





Thread Type **NPT** acc. to ANSI ASME B1.20.1

Outer Thread Size (Male)	Clamping Range		Shield Wire Ø min-max mm	Outer Thread Length TL mm	Spanner Width			Outer Ø D mm	max. Height H mm	Part Number
	Inner Sheath Ø min-max mm	Ø min-max mm			Cap SW Cap mm	Upper Body SW Upper Body mm	Lower Body SW Lower Body mm			
NPT 3/8"	6,0 - 11,0	9,0 - 16,0	0,2 - 0,8	15,5	24	24	24	27,5	45,0	KBCO01N
NPT 1/2"	6,0 - 11,0	9,0 - 16,0	0,2 - 0,8	20,1	24	24	24	27,5	45,0	KBCO15N
	8,5 - 14,5	12,0 - 20,0	0,2 - 0,8	20,1	30	30	29	33,0	48,0	KBCO1N
NPT 3/4"	8,5 - 14,5	12,0 - 20,0	0,2 - 0,8	20,4	30	30	36	40,0	48,0	KBCO25N
	12,0 - 20,0	16,0 - 26,0	0,2 - 0,7	20,4	36	36	36	40,0	54,0	KBCO2N
NPT 1"	12,0 - 20,0	16,0 - 26,0	0,2 - 0,7	25,5	36	36	44	52,5	54,0	KBCO35N
	17,0 - 26,0	20,0 - 33,0	0,2 - 0,7	25,5	46	46	44	52,5	64,5	KBCO3N
NPT 1 1/4"	17,0 - 26,0	20,0 - 33,0	0,2 - 0,7	26,1	46	46	55	64,0	64,5	KBCO45N
	23,0 - 32,0	29,0 - 41,0	0,2 - 0,7	26,1	55	55	55	64,0	67,0	KBCO4N
NPT 1 1/2"	23,0 - 32,0	29,0 - 41,0	0,2 - 0,7	26,5	55	55	65	74,0	67,0	KBCO55N
	29,0 - 39,0	36,0 - 52,0	0,2 - 1,0	26,5	65	65	65	74,0	77,7	KBCO5N
NPT 2"	29,0 - 41,0	36,0 - 52,0	0,2 - 1,0	27,4	65	65	80	92,0	77,7	KBCO65N
	44,0 - 52,0	50,0 - 65,0	0,2 - 1,0	27,4	80	80	80	92,0	90,7	KBCO6N
NPT 2 1/2"	44,0 - 56,0	50,0 - 65,0	0,2 - 1,0	40,4	80	80	95	107,5	90,7	KBCO75N
	54,5 - 63,0	61,0 - 78,0	0,2 - 1,0	40,4	95	95	95	107,5	103,7	KBCO7N
NPT 3"	54,5 - 68,0	61,0 - 78,0	0,2 - 1,0	41,9	95	95	95	118,0	103,7	KBCO805N
	67,0 - 73,0	75,0 - 89,0	0,2 - 1,0	41,9	106	106	106	118,0	100,2	KBCO80N
NPT 3 1/2"	67,0 - 77,0	75,0 - 89,0	0,2 - 1,0	43,2	115	115	115	133,0	100,0	KBCO8N
NPT 4"	75,0 - 91,0	88,0 - 104,0	0,2 - 1,0	44,5	127	127	127	145,0	114,0	KBCO9N

Diaphragm Sealed Glands for SWA and AWA Cables

CORONA



Technical Details		
Body, Cap	Brass, Brass Nickel Plated, Stainless Steel 316L	
Inner Part	Brass, Brass Nickel Plated, Stainless Steel 316L	
Material	Seal	Silicone
	O-ring	Silicone
	Lower Insert	PA 6 (Polyamide 6)
Ingress Protection Rating	IP 68 - 5 Bar, 30 min IP 66	
Operating Temperature	Seal Material Silicone -40°C to +80°C	
Equipment For	Gas & Dust potentially explosive atmospheres	
Suitable for use in	Group II Gas Group IIC ZONE1/ZONE2	
	Group III Dust Group IIIC ZONE21/ZONE 22	
Equipment Marking	Group II/III Ex II 2GD Ex db IIC Gb Ex eb IIC Gb Ex tb IIIC Db	
Marking Example *	BMD KBC... CE 0722  II 2GD Ex db IIC Gb Ex eb IIC Gb Ex tb IIIC Db IP66/68 Ta -40°C to +80°C	
Thread Type	<ul style="list-style-type: none"> • Metric (M) ISO Pitch 1,5 • NPT (N) ANSI ASME B1.20.1 • Other thread types also available upon request. 	
Cable Type	SWA - AWA	
Accessories	<ul style="list-style-type: none"> • Lock nuts • Gaskets (Washers) • Serrated Washers • Shrouds • Earth tags 	
Remarks	<ul style="list-style-type: none"> • Gasket available in Metric threads. For NPT threads gasket must be ordered separately. • Accessories must be ordered separately. 	
Approvals	Certificate Number	Standards
	CESI 13 ATEX 033X	EN 60079-0:2012+A11:2013 EN 60079-1:2014 EN 60079-7:2015 EN 60079-31:2014
	IECEx CES 17.0042X	IEC 60079-0:2011 Edition:6 IEC 60079-1:2014 Edition:7 IEC 60079-31:2013 Edition:2 IEC 60079-7:2015-08 Edition:5
	№ TC RU C-TR.AA87.B.00941	ГОСТ 31610.0-2014 ГОСТ IEC 60079-1:2013 ГОСТ IEC 60079-31:2013

-For more information see our webpage.

* The standard marking consists ATEX & IECEx only. Marking acc. to other standards on request.



Order Coding								
Part Number	Material	Seal	-	Gasket (Washer)	Serrated Washer	Lock Nut	Shroud	Earth Tag
Mandatory	Mandatory	Mandatory	-	Option	Option	Option	Option	Option
See table	B Brass BN Brass Nickel plated X Stainless steel 316L	S Silicone	-	WS Silicone	WSR Serrated washer	L Lock nut	S Shroud	E Earth tag
Example								
KBC4N	BN	S	-	WS	WSR	L	S	E

CORONA

Diaphragm Sealed Glands for SWA and AWA Cables

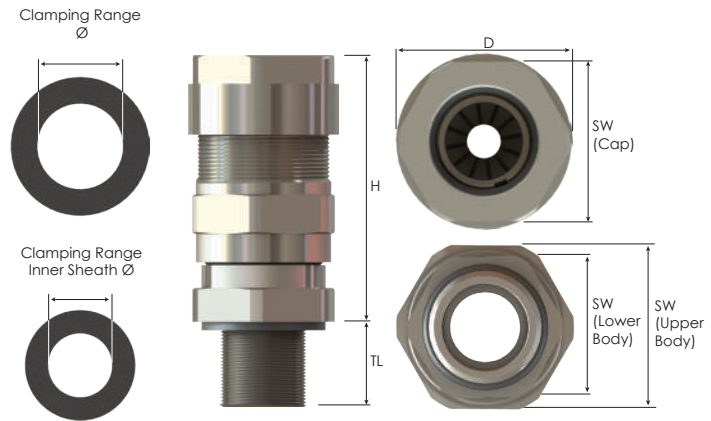

Thread Type METRIC acc. to ISO 965 - 3										
Outer Thread Size (Male)	Clamping Range		Armour Wire Ø min-max mm	Outer Thread Length TL mm	Cap SW Cap mm	Spanner Width		Outer Ø D mm	max. Height H mm	Part Number
	Inner Sheath Ø min-max mm	Ø min-max mm				Upper Body SW Upper Body mm	Lower Body SW Lower Body mm			
M16x1,5	6,0 - 11,0	9,0 - 16,0	0,8 - 1,25	15,0	24	24	24	27,5	45,0	KBC01M
M20x1,5	6,0 - 11,0	9,0 - 16,0	0,8 - 1,25	15,0	24	24	24	27,5	45,0	KBC1SM
	8,5 - 14,5	12,0 - 20,0	0,8 - 1,25	15,0	30	30	29	33,0	48,0	KBC1M
M25x1,5	8,5 - 14,5	12,0 - 20,0	0,8 - 1,25	15,0	30	30	36	40,0	48,0	KBC2SM
	12,0 - 20,0	16,0 - 26,0	1,25 - 1,6	15,0	36	36	36	40,0	54,0	KBC2M
M32x1,5	12,0 - 20,0	16,0 - 26,0	1,25 - 1,6	15,0	36	36	44	52,5	54,0	KBC3SM
	17,0 - 26,0	20,0 - 33,0	1,6 - 2,0	15,0	46	46	44	52,5	64,5	KBC3M
M40x1,5	17,0 - 26,0	20,0 - 33,0	1,6 - 2,0	15,0	46	46	55	64,0	64,5	KBC4SM
	23,0 - 32,0	29,0 - 41,0	1,6 - 2,0	15,0	55	55	55	64,0	67,0	KBC4M
M50x1,5	23,0 - 32,0	29,0 - 41,0	1,6 - 2,0	15,0	55	55	65	74,0	67,0	KBC5SM
	29,0 - 41,0	36,0 - 52,0	1,8 - 2,5	15,0	65	65	65	74,0	77,7	KBC5M
M63x1,5	29,0 - 41,0	36,0 - 52,0	1,8 - 2,5	15,0	65	65	80	92,0	77,7	KBC6SM
	44,0 - 56,0	50,0 - 65,0	1,8 - 2,5	15,0	80	80	80	92,0	90,7	KBC6M
M75x1,5	44,0 - 56,0	50,0 - 65,0	1,8 - 2,5	15,0	80	80	95	107,5	90,7	KBC7SM
	54,5 - 68,0	61,0 - 78,0	1,8 - 2,5	15,0	95	95	95	107,5	103,7	KBC7M
M80x1,5	54,5 - 68,0	61,0 - 78,0	1,8 - 2,5	15,0	95	95	95	118,0	103,7	KBC80SM
	67,0 - 73,0	75,0 - 89,0	2,0 - 3,5	15,0	106	106	106	118,0	100,2	KBC80M
M90x1,5	67,0 - 77,0	75,0 - 89,0	2,0 - 3,5	15,0	115	115	115	133,0	100,0	KBC8M
M100x1,5	75,0 - 91,0	88,0 - 104,0	2,5 - 4,0	15,0	127	127	127	145,0	114,0	KBC9M

Diaphragm Sealed Glands for SWA and AWA Cables

CORONA



Technical Details		
Material	Body, Cap	Brass, Brass Nickel Plated, Stainless Steel 316L
	Inner Part	Brass, Brass Nickel Plated, Stainless Steel 316L
	Seal	Silicone
	O-ring	Silicone
	Lower Insert	PA 6 (Polyamide 6)
Ingress Protection Rating	IP 68 - 5 Bar, 30 min IP 66	
Operating Temperature	Seal Material Silicone -40°C to +80°C	
Equipment For	Gas & Dust potentially explosive atmospheres	
Suitable for use in	Group II	Gas Group IIC ZONE1/ZONE2
	Group III	Dust Group IIIC ZONE21/ZONE 22
Equipment Marking	Group II/III Ex II 2GD Ex db IIC Gb Ex eb IIC Gb Ex tb IIIC Db	
Marking Example *	BMD KBC.. CE 0722 II 2GD Ex db IIC Gb Ex eb IIC Gb Ex tb IIIC Db IP66/68 Ta -40°C to +80°C	
Thread Type	<ul style="list-style-type: none"> • Metric (M) ISO Pitch 1,5 • NPT (N) ANSI ASME B1.20.1 • Other thread types also available upon request. 	
Cable Type	SWA - AWA	
Accessories	<ul style="list-style-type: none"> • Lock nuts • Gaskets (Washers) • Serrated Washers • Shrouds • Earth tags 	
Remarks	<ul style="list-style-type: none"> • Gasket available in Metric threads. For NPT threads gasket must be ordered separately. • Accessories must be ordered separately. 	
Approvals	Certificate Number	Standards
	CESI 13 ATEX 033X	EN 60079-0:2012+A11:2013 EN 60079-1:2014 EN 60079-7:2015 EN 60079-31:2014
	IECEx CES 17.0042X	IEC 60079-0:2011 Edition:6 IEC 60079-1:2014 Edition:7 IEC 60079-31:2013 Edition:2 IEC 60079-7:2015-08 Edition:5
	№ TC RU C-TR.AA87.B.00941	ГОСТ 31610.0-2014 ГОСТ IEC 60079-1:2013 ГОСТ IEC 60079-31:2013

-For more information see our webpage.

* The standard marking consists ATEX & IECEx only. Marking acc. to other standards on request.



Order Coding							
Part Number	Material	Seal	- Gasket (Washer)	Serrated Washer	Lock Nut	Shroud	Earth Tag
See table	Mandatory	Mandatory	- Option	Option	Option	Option	Option
	B Brass	S Silicone	- WS Silicone	WSR Serrated washer	L Lock nut	S Shroud	E Earth tag
	BN Brass Nickel plated		WF Fiber				
X Stainless steel 316L							
Example							
KBC4N	BN	S	- WS	WSR	L	S	E

CORONA

Diaphragm Sealed Glands for SWA and AWA Cables

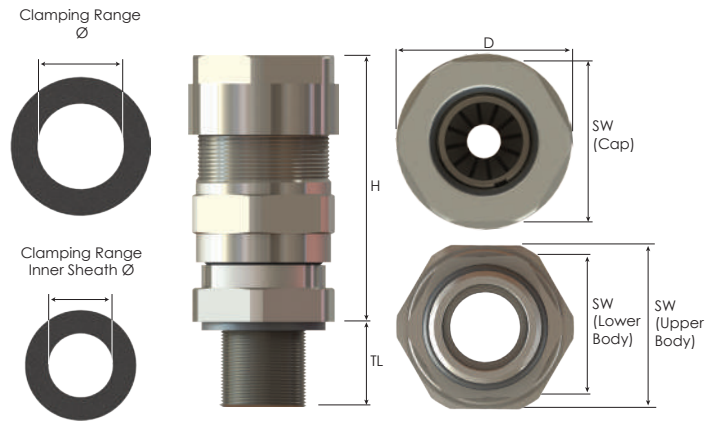





Thread Type NPT acc. to ANSI ASME B1.20.1										
Outer Thread Size (Male)	Clamping Range		Armour Wire Ø min-max mm	Outer Thread Length TL mm	Cap SW Cap mm	Spanner Width		Outer Ø D mm	max. Height H mm	Part Number
	Inner Sheath Ø min-max mm	Ø min-max mm				Upper Body SW Upper Body mm	Lower Body SW Lower Body mm			
NPT 3/8"	6,0 - 11,0	9,0 - 16,0	0,8 - 1,25	15,5	24	24	24	27,5	45,0	KBC01N
NPT 1/2"	6,0 - 11,0	9,0 - 16,0	0,8 - 1,25	20,1	24	24	24	27,5	45,0	KBC15N
	8,5 - 14,5	12,0 - 20,0	0,8 - 1,25	20,1	30	30	29	33,0	48,0	KBC1N
NPT 3/4"	8,5 - 14,5	12,0 - 20,0	0,8 - 1,25	20,4	30	30	36	40,0	48,0	KBC25N
	12,0 - 20,0	16,0 - 26,0	1,25 - 1,6	20,4	36	36	36	40,0	54,0	KBC2N
NPT 1"	12,0 - 20,0	16,0 - 26,0	1,25 - 1,6	25,5	36	36	44	52,5	54,0	KBC35N
	17,0 - 26,0	20,0 - 33,0	1,6 - 2,0	25,5	46	46	44	52,5	64,5	KBC3N
NPT 1 1/4"	17,0 - 26,0	20,0 - 33,0	1,6 - 2,0	26,1	46	46	55	64,0	64,5	KBC45N
	23,0 - 32,0	29,0 - 41,0	1,6 - 2,0	26,1	55	55	55	64,0	67,0	KBC4N
NPT 1 1/2"	23,0 - 32,0	29,0 - 41,0	1,6 - 2,0	26,5	55	55	65	74,0	67,0	KBC55N
	29,0 - 39,0	36,0 - 52,0	1,8 - 2,5	26,5	65	65	65	74,0	77,7	KBC5N
NPT 2"	29,0 - 41,0	36,0 - 52,0	1,8 - 2,5	27,4	65	65	80	92,0	77,7	KBC65N
	44,0 - 52,0	50,0 - 65,0	1,8 - 2,5	27,4	80	80	80	92,0	90,7	KBC6N
NPT 2 1/2"	44,0 - 56,0	50,0 - 65,0	1,8 - 2,5	40,4	80	80	95	107,5	90,7	KBC75N
	54,5 - 63,0	61,0 - 78,0	1,8 - 2,5	40,4	95	95	95	107,5	103,7	KBC7N
NPT 3"	54,5 - 68,0	61,0 - 78,0	1,8 - 2,5	41,9	95	95	95	118,0	103,7	KBC805N
	67,0 - 73,0	75,0 - 89,0	2,0 - 3,5	41,9	106	106	106	118,0	100,2	KBC80N
NPT 3 1/2"	67,0 - 77,0	75,0 - 89,0	2,0 - 3,5	43,2	115	115	115	133,0	100,0	KBC8N
NPT 4"	75,0 - 91,0	88,0 - 104,0	2,5 - 4,0	44,5	127	127	127	145,0	114,0	KBC9N

Barrier Cable Glands for All Types of Armoured Cables

CENTAURUS-A



Technical Details			
Material	Body, Cap	Brass, Brass Nickel Plated, Stainless Steel 316L	
	Inner Part	Brass, Brass Nickel Plated, Stainless Steel 316L	
	Seal	Silicone	
	O-ring	Silicone	
Ingress Protection Rating	IP 68 - 5 Bar, 30 min IP 66		
Operating Temperature	Seal Material	Silicone	
	-60°C to +60°C		
Service Temperature	Seal Material	Silicone	
	-60°C to +100°C		
Equipment For	Gas & Dust potentially explosive atmospheres		
Suitable for use in	Group II	Gas Group IIC	ZONE1/ZONE2
	Group III	Dust Group IIIC	ZONE21/ZONE 22
	Ex II 2GD - Ex db IIC Gb Ex eb IIC Gb Ex tb IIIC Db		
Equipment Marking	Ex II 2GD - Ex db IIC Gb Ex eb IIC Gb Ex tb IIIC Db		
Marking Example *	BMD KBCTA.. CE 0722  II 2GD Ex db IIC Gb Ex eb IIC Gb Ex tb IIIC Db Ta -60°C to +60°C IP66/68 CESI 17 ATEX 007X IECEx CES 17.0029X		
Thread Type	<ul style="list-style-type: none"> • Metric (M) ISO Pitch 1,5 • NPT (N) ANSI ASME B1.20.1 • Other thread types also available upon request. 		
Cable Type	SWA - SWB - STA - Shielded		
Accessories	<ul style="list-style-type: none"> • Lock nuts • Gaskets (Washers) • Serrated Washers • Shrouds • Earth tags 		
Remarks	<ul style="list-style-type: none"> • O-ring available in Metric outer threads. • Accessories must be ordered separately. 		
Approvals	Certificate Number	Standards	
	CESI 17 ATEX 0007X	EN 60079-0:2012+A11:2013 EN 60079-1:2014 EN 60079-7:2015 EN 60079-31:2014	
	IECEx CES 17.0029X	IEC 60079-0:2011 Edition:6 IEC 60079-1:2014 Edition:7 IEC 60079-31:2013 Edition:2 IEC 60079-7:2015-08 Edition:5	
	№ TC RU C-TR.AA87.B.00941	ГОСТ 31610.0-2014 ГОСТ IEC 60079-1:2013 ГОСТ IEC 60079-31:2013	

-For more information see our webpage.

* The standard marking consists ATEX & IECEx only. Marking acc. to other standards on request.



Order Coding							
Part Number	Material	Seal	Gasket (Washer)	Serrated Washer	Lock Nut	Shroud	Earth Tag
Mandatory	Mandatory	Mandatory	- Option	Option	Option	Option	Option
See table	B Brass BN Brass Nickel plated X Stainless Steel 316L	S Silicone	- WS Silicone WF Fiber	WSR Serrated washer	L Lock nut	S Shroud	E Earth tag
Example							
KBACTA3M	BN	S	- WS	WSR	L	S	E

CENTAURUS-A

Barrier Cable Glands for All Types of Armoured Cables

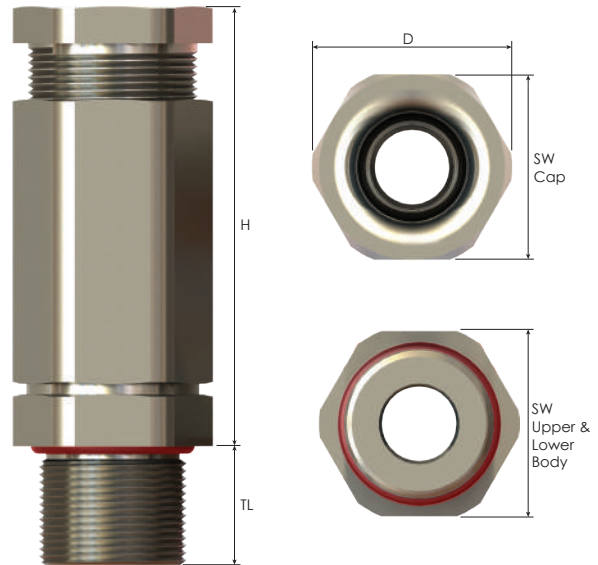

Thread Type **METRIC** acc. to ISO 965-3

Outer Thread Size (Male)	Clamping Range Ø min-max mm	Over Conductors max Ø mm	Armour Wire max Ø mm	Outer Thread Length TL mm	Cap		Spanner Width		Lower Body	Outer Ø D mm	max. Height H mm	Part Number	Need Barrier Compound Material Per Pc. (g)
					SW Cap mm	SW Upper Body mm	SW Lower Body mm	SW Lower Body mm					
M20x1,5	6,0 - 13,0	9,5	1,3	16,0	25	25	25	25	25	27,0	63,5	KBCTA1SM	7
	8,0 - 15,0	9,5	1,3	16,0	25	25	25	25	25	27,0	63,5	KBCTA1M	7
	13,5 - 21,0	12,0	1,3	16,0	30	30	30	30	30	33,0	65,0	KBCTA1LM	6
M25x1,5	8,0 - 15,0	9,5	1,3	16,0	25	25	30	30	30	33,0	63,5	KBCTA2SM	7
	13,5 - 21,0	12,0	1,3	16,0	30	30	30	30	30	33,0	65,0	KBCTA2M	6
	18,0 - 27,0	15,0	1,6	16,0	40	40	40	40	44,5	72,5	KBCTA2LM	14	
M32x1,5	18,0 - 27,0	15,0	1,6	16,0	40	40	40	40	44,5	72,5	KBCTA3M	14	
	23,0 - 33,0	21,5	1,6	16,0	43	43	43	43	47,0	74,5	KBCTA3LM	26	
M40x1,5	23,0 - 33,0	21,5	1,6	16,0	43	43	45	45	50,0	74,5	KBCTA4SM	26	
	29,0 - 40,0	29,0	2,0	16,0	50	50	50	50	55,5	82,5	KBCTA4M	50	
M50x1,5	29,0 - 40,0	29,0	2,0	16,0	50	50	55	55	61,0	82,5	KBCTA5SM	50	
	35,0 - 48,0	37,0	2,5	16,0	58	58	58	58	64,0	90,5	KBCTA5M	82	
M63x1,5	35,0 - 48,0	37,0	2,5	20,0	58	58	68	68	75,0	90,5	KBCTA6SM	82	
	42,0 - 56,0	46,0	2,5	20,0	75	75	75	75	83,0	120,0	KBCTA6M	180	
M75x1,5	42,0 - 56,0	46,0	2,5	20,0	75	75	80	80	89,0	120,0	KBCTA7SM	180	
	54,0 - 70,0	58,0	3,2	20,0	100	100	100	100	110,5	126,0	KBCTA7M	290	
M90x1,5	54,0 - 70,0	58,0	3,2	20,0	100	100	100	100	110,5	126,0	KBCTA8M	290	

*Barrier compound is served as 50 g standard.







Thread Type **NPT** acc. to ANSI ASME B1.20.1

Outer Thread Size (Male)	Clamping Range Ø min-max mm	Over Conductors max Ø mm	Armour Wire max. Ø mm	Outer Thread Length TL mm	Cap		Spanner Width		Lower Body	Outer Ø D mm	max. Height H mm	Part Number	Barrier Compound Material Per Pc. (g)
					SW Cap mm	SW Upper Body mm	SW Lower Body mm	SW Lower Body mm					
NPT 1/2	6,0 - 13,0	9,5	1,3	21,0	25	25	25	25	25	27,0	63,5	KBCTA1SN	7
	8,0 - 15,0	9,5	1,3	21,0	25	25	25	25	25	27,0	63,5	KBCTA1N	7
	13,5 - 21,0	12,0	1,3	21,0	30	30	30	30	30	33,0	65,0	KBCTA1LN	6
NPT 3/4"	8,0 - 15,0	9,5	1,3	21,0	25	25	30	30	30	33,0	63,5	KBCTA2SN	7
	13,5 - 21,0	12,0	1,3	21,0	30	30	30	30	30	33,0	65,0	KBCTA2N	6
	18,0 - 27,0	15,0	1,6	21,0	40	40	40	40	44,5	72,5	KBCTA2LN	14	
NPT 1"	18,0 - 27,0	15,0	1,6	26,0	40	40	40	40	44,5	72,5	KBCTA3N	14	
	23,0 - 33,0	21,5	1,6	26,0	43	43	43	43	47,0	74,5	KBCTA3LN	26	
NPT 1 1/4"	23,0 - 33,0	21,5	1,6	28,0	43	43	45	45	50,0	74,5	KBCTA4SN	26	
	29,0 - 40,0	29,0	2,0	28,0	50	50	50	50	55,5	82,5	KBCTA4N	50	
NPT 1 1/2"	29,0 - 40,0	29,0	2,0	28,0	50	50	55	55	61,0	82,5	KBCTA5N	50	
NPT 2"	35,0 - 48,0	37,0	2,5	28,0	58	58	65	65	72,0	90,5	KBCTA6N	82	
NPT 2 1/2"	42,0 - 56,0	46,0	2,5	41,0	75	75	80	80	89,0	120,0	KBCTA7N	180	
NPT 3"	54,0 - 70,0	58,0	3,2	43,0	100	100	100	100	110,5	126,0	KBCTA8N	290	

*Barrier compound is served as 50 g standard.

EMC Cable Glands for Shielded Cables

E-VELA

Technical Details			
Body, Cap	Brass, Brass Nickel Plated, Stainless Steel 316L, Aluminium		
Inner Part	Brass, Brass Nickel Plated, Stainless Steel 316L, Aluminium		
Material	Seal	CR (Chloroprene), Silicone	
	O-ring	CR (Chloroprene), Silicone	
	Spring	Special Copper Alloy	
Ingress Protection Rating	IP 68 - 5 Bar, 30 min IP 66		
Operating Temperature	Seal Material		
	CR (Chloroprene)	Silicone	
	Ex d/tb	-40°C to +80°C	-60°C to +80°C
Ex e/tb	-60°C to +80°C	-60°C to +140°C	
Equipment For	Gas & Dust potentially explosive atmospheres		
Suitable for use in	Group II	Gas Group IIC	ZONE1/ZONE2
	Group III	Dust Group IIIC	ZONE21/ZONE 22
Equipment Marking	Ex II 2GD Ex db IIC Gb Ex eb IIC Gb Ex tb IIIC Db		
Marking Example *	BMD EBS.. CE 0722  2GD Ex db IIC Gb Ex eb IIC Gb Ex tb IIIC Db Ta-40°C to +80°C IP66/68 CESI 13 ATEX 018X IECEx CES 13.0006X		
Thread Type	<ul style="list-style-type: none"> • Metric (M) ISO Pitch 1,5 • NPT (N) ANSI ASME B1.20.1 • Other thread types also available upon request. 		
Cable Type	Non Armoured, Shielded		
Accessories	<ul style="list-style-type: none"> • Lock nuts • Gaskets (Washers) • Serrated Washers • Shrouds • Earth tags • Dome plugs 		
	<ul style="list-style-type: none"> • Accessories must be ordered separately. • O-ring available in Metric outer threads. 		
Remarks			
Approvals	Certificate Number	Standards	
	IMQ 13 ATEX 018X	EN 60079-0:2012+A11:2013 EN 60079-7:2015 EN 60079-31:2014 EN 60079-1:2014	
	IECEX IMQ 13.0006X	IEC 60079-0:2011 Edition:6 IEC 60079-7:2015 Edition:5 IEC 60079-31:2013 Edition:2 IEC 60079-1:2014 Edition:7	
	20150501-E474828	UL 2225, CAN/CSA-C22.2 No. 60079-0:11 CAN/CSA C22.2 No. 60079-7:12 CAN/CSA-C22.2 No. 60079-31:12	
	№ TC RU C-TR.AA87.B.00941	ГОСТ 31610.0-2014 ГОСТ IEC 60079-1:2013 ГОСТ IEC 60079-31:2013	
	DNV 12.0052 X	ABNT NBR IEC 60079-0:2013 ABNT NBR IEC 60079-1:2009 ABNT NBR IEC 60079-7:2008 ABNT NBR IEC 60079-31:2011	
	E-14044	IEC/EN60079-0 IEC/EN60079-7 IEC/EN60079-31 IEC/EN60079-1 IEC/EN 62444	

-For more information see our webpage.

* The standard marking consists ATEX & IECEx only. Marking acc. to other standards on request.



Order Coding								
Part Number	Material	Seal	- Gasket (Washer)	Serrated Washer	Lock Nut	Shroud	Earth Tag	for Ex e
Mandatory	Mandatory	Mandatory	- Option	Option	Option	Option	Option	Option
See table	B Brass BN Brass Nickel plated X Stainless Steel 316L A Aluminium	C Chloroprene S Silicone	- WC Chloroprene WS Silicone WF Fiber	WSR Serrated washer	L Lock nut	S Shroud	E Earth tag	TL9
Example								
EBS1N	BN	S	- WC	WSR	L	S	E	TL9

E-VELA

EMC Cable Glands for Armoured Cables

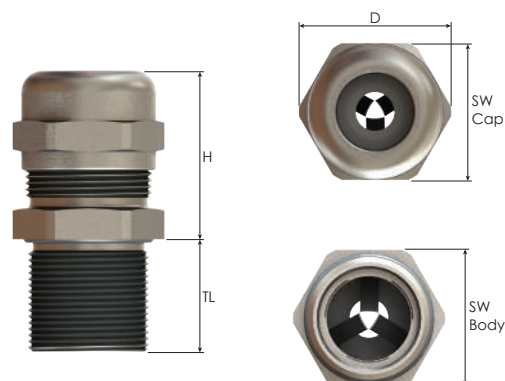

Thread Type METRIC acc. to ISO 965 - 3

Outer Thread Size (Male)	Clamping Range		Shield Diameter Ø min - max mm	Outer Thread Length Ex-e min. Ex-d/e min.		Spanner Width Cap Body		Outer Ø D mm	max. Height H mm	Part Number
	Ø min - max mm	Seal Type		TL mm	TL mm	SW Cap mm	SW Body mm			
M8x1,25	2,0 - 4,0	Single	1,5 - 3,5	5,0	-	11	11	12,0	18,0	EBS01SM
M16x1,5	4,0 - 8,0	Double	2,5 - 5,0	9,0	16,0	20	20	22,0	30,5	EBS01SM
M20x1,5	4,0 - 8,0	Double	2,5 - 5,0	9,0	16,0	22	22	24,5	30,5	EBS01M
M20x1,5	4,0 - 12,0	Triple	2,5 - 10,0	9,0	18,0	22	22	24,5	28,5	EBS1M
M25x1,5	10,0 - 18,0	Triple	8,0 - 14,0	9,0	16,0	28	28	31,0	32,0	EBS2M
M32x1,5	14,0 - 24,0	Triple	12,0 - 20,0	9,0	19,0	35	35	39,0	35,0	EBS3M
M40x1,5	22,0 - 32,0	Triple	18,0 - 28,0	9,0	20,0	45	45	49,5	42,5	EBS4M
M50x1,5	26,0 - 35,0	Triple	22,0 - 31,0	9,0	20,0	50	55	61,0	48,5	EBS5M
M63x1,5	35,0 - 45,0	Triple	31,0 - 41,0	9,0	20,0	64	68	75,0	45,0	EBS6M
M75x1,5	46,0 - 62,0	Triple	42,0 - 58,0	9,0	20,0	80	80	89,0	53,0	EBS7M
M90x1,5	60,0 - 75,0	Triple	56,0 - 71,0	9,0	20,0	95	95	105,0	57,0	EBS8M
M100x1,5	75,0 - 85,0	Triple	71,0 - 81,0	9,0	20,0	105	105	117,0	56,0	EBS10M
M110x1,5	85,0 - 95,0	Triple	81,0 - 91,0	9,0	20,0	115	115	128,0	58,0	EBS11M

Thread Type NPT acc. to ANSI ASME B1.20.1

Outer Thread Size (Male)	Clamping Range		Shield Diameter Ø min - max mm	Outer Thread Length TL mm	Spanner Width Cap Body		Outer Ø D mm	max. Height H mm	Part Number
	Ø min - max mm	Seal Type			SW Cap mm	SW Body mm			
NPT 3/8"	4,0 - 8,0	Double	2,5 - 5,0	16,0	20	20	22,0	30,5	EBS01SN
NPT 1/2"	4,0 - 8,0	Double	2,5 - 5,0	16,0	22	22	24,5	30,5	EBS01N
NPT 1/2"	4,0 - 12,0	Triple	2,5 - 10,0	18,0	22	22	24,5	28,5	EBS1N
NPT 3/4"	10,0 - 18,0	Triple	8,0 - 14,0	16,0	28	28	31,0	32,5	EBS2N
NPT 1"	14,0 - 24,0	Triple	12,0 - 20,0	20,0	35	35	39,0	35,0	EBS3N
NPT 1 1/4"	22,0 - 32,0	Triple	18,0 - 28,0	20,0	45	45	49,5	42,5	EBS4N
NPT 1 1/2"	26,0 - 35,0	Triple	22,0 - 31,0	20,0	50	55	61,0	45,0	EBS5N
NPT 2"	35,0 - 45,0	Triple	31,0 - 41,0	20,0	64	68	75,0	45,0	EBS6N
NPT 2 1/2"	46,0 - 62,0	Triple	42,0 - 58,0	21,0	80	80	89,0	56,5	EBS7N
NPT 3"	60,0 - 75,0	Triple	56,0 - 71,0	21,0	95	95	105,0	65,0	EBS8N
NPT 4"	75,0 - 85,0	Triple	71,0 - 81,0	21,0	105	115	128,0	56,5	EBS10N
NPT 4"	85,0 - 95,0	Triple	81,0 - 91,0	21,0	115	115	128,0	58,0	EBS11N

CABLE GLANDS for NON-ARMOURED CABLES for Gas & Dust Application



E-Octans
E-Octans Flat
Crater
Centaurus-N Barrier

186 - 189
190 - 191
192 - 193
194 - 195

Ex Glands / Group II - III / Gas & Dust Ex II 2GD / Ex d IIC Gb - Ex e IIC Gb - Ex tb IIIC Db



Explosive gases, vapors and dusts have different chemical properties that affect the likelihood and severity of an explosion. Such properties include flame temperature, minimum ignition energy, upper and lower explosive limits, and molecular weight. Empirical testing is done to determine parameters such as the maximum experimental safe gap, minimum ignition current, explosion pressure and time to peak pressure, spontaneous ignition temperature, and maximum rate of pressure rise. Every substance has a differing combination of properties but it is found that they can be ranked into similar ranges, simplifying the selection of equipment for hazardous areas.

Flammability of combustible liquids are defined by their flash-point. The flash-point is the temperature at which the material will generate sufficient quantity of vapor to form an ignitable mixture. The flash point determines if an area needs to be classified. A material may have a relatively low autoignition temperature yet if its flash-point is above the ambient temperature, then the area may not need to be classified. Conversely if the same material is heated and handled above its flash-point, the area must be classified.







Each chemical gas or vapour used in industry is classified into a gas group.

Flammable dusts when suspended in air can explode. An old system of area classification to a British standard used a system of letters to designate the zones. This has been replaced by a European numerical system, as set out in directive 1999/92/EU implemented in the UK as the Dangerous Substances and Explosives Atmospheres Regulations 2002

The boundaries and extent of these three dimensional zones should be decided by a competent person. There must be a site plan drawn up of the factory with the zones marked on.

Cable Glands for Non-armoured Cables

E-OCTANS

Technical Details	
Material	Body, Cap Brass, Brass Nickel Plated, Stainless Steel 316L, Aluminium Seal CR (Chloroprene), Silicone O-ring CR (Chloroprene), Silicone
Ingress Protection Rating	IP 68 - 5 Bar, 30 min IP 66
Operating Temperature	Seal Material CR (Chloroprene) -40°C to +80°C Silicone -60°C to +140°C
Equipment For	Gas & Dust potentially explosive atmospheres
Suitable for use in	Group II Gas Group IIC ZONE1/ZONE2 Group III Dust Group IIIC ZONE21/ZONE 22
Equipment Marking	Ex II 2GD Ex db IIC Gb Ex eb IIC Gb Ex tb IIIC Db
Marking Example *	BMD EBU.. CE 0722  II 2GD Ex db IIC Gb Ex eb IIC Gb Ex tb IIIC Db Ta-40°C to +80°C IP66/68 IECEx CES 13.0006X CESI 13 ATEX 018X
Thread Type	• Metric (M) ISO Pitch 1,5 • NPT (N) ANSI ASME B1.20.1 • Other thread types also available upon request.
Cable Type	Non Armoured
Accessories	• Lock nuts • Gaskets (Washers) • Serrated Washers • Shrouds • Earth tags • Dome plugs
Remarks	• Accessories must be ordered separately. • O-ring available in Metric outer threads.
Approvals	Certificate Number Standards
	IMQ 13 ATEX 018X EN 60079-0:2012+A11:2013 EN 60079-7:2015 EN 60079-31:2014 EN 60079-1:2014
	IECEx IMQ 13.0006X IEC 60079-0:2011 Edition:6 IEC 60079-7:2015 Edition:5 IEC 60079-31:2013 Edition:2 IEC 60079-1:2014 Edition:7
	20150501-E474828 20161226-E199260 UL 2225, CAN/CSA-C22.2 No. 60079-0:11 CAN/CSA C22.2 No. 60079-7:12 CAN/CSA-C22.2 No. 60079-31:12 UL 514B UL50E
	№ TC RU C-TR.AA87.B.00941 ГОСТ 31610.0-2014 ГОСТ IEC 60079-1:2013 ГОСТ IEC 60079-31:2013
	DNV 12.0052 X ABNT NBR IEC 60079-0:2013 ABNT NBR IEC 60079-1:2009 ABNT NBR IEC 60079-7:2008 ABNT NBR IEC 60079-31:2011
	E-14044 IEC/EN60079-0 IEC/EN60079-7 IEC/EN60079-31 IEC/EN60079-1 IEC/EN 62444

-For more information see our webpage.

* The standard marking consists ATEX & IECEx only. Marking acc. to other standards on request.



Order Coding									
Part Number	Material	Seal	Gasket (Washer)	Seal Plug	Serrated Washer	Lock Nut	Shroud	Earth Tag	for Ex e
Mandatory	Mandatory	Mandatory	- Option	Option	Option	Option	Option	Option	Option
See table	B Brass BN Brass Nickel plated X Stainless Steel 316L A Aluminium	C Chloroprene S Silicone	- WC Chloroprene WS Silicone WF Fiber	P Dome Plug	WSR Serrated washer	L Lock nut	S Shroud	E Earth tag	TL9
Example									
EBU1N (*BUE)	BN	S	- WC	P	WSR	L	S	E	TL9

* BUE: Part Number is valid for Customs Union certificate.

E-OCTANS

Cable Glands for Non-armoured Cables

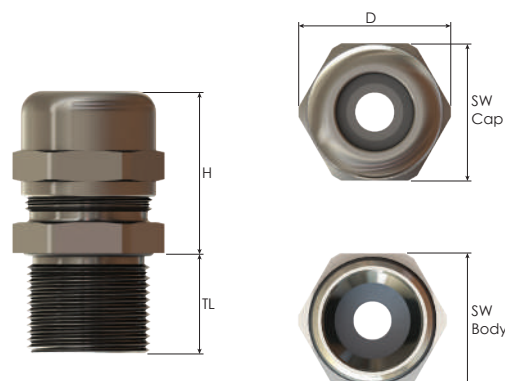

Thread Type **METRIC** acc. to ISO 965 - 3

Outer Thread Size (Male)	Clamping Range		Outer Thread Length		Spanner Width		Outer Ø	max. Height	Part Number
	Ø min - max mm	Seal Type	Ex-e min.	Ex-d/e min.	Cap	Body			
			TL mm		SW Cap mm	SWBody mm	D mm	H mm	
M12x1,5	3,0 - 8,0	Double	9,0	16,0	20	20	22,0	29,0	EBU0M
	4,0 - 8,0	Triple	9,0	16,0	22	22	24,5	33,0	EBU0SM
M16x1,5	3,0 - 9,0	Double	9,0	16,0	20	20	22,0	29,0	EBU01SM
	4,0 - 12,0	Triple	9,0	16,0	22	22	24,5	33,0	EBU01M
M20x1,5	3,0 - 9,0	Double	9,0	16,0	20	22	24,5	29,0	EBU1SM
	4,0 - 12,0	Triple	9,0	16,0	22	22	24,5	29,0	EBU1M
	10,0 - 16,0	Triple	9,0	16,0	28	28	31,0	32,0	EBU12M
M25x1,5	4,0 - 12,0	Triple	9,0	16,0	22	28	31,0	29,0	EBU2SM
	10,0 - 18,0	Triple	9,0	16,0	28	28	31,0	32,5	EBU2M
	14,0 - 20,0	Triple	9,0	16,0	35	35	39,0	36,0	EBU23M
M32x1,5	10,0 - 18,0	Triple	9,0	16,0	28	35	39,0	32,5	EBU3SM
	14,0 - 24,0	Triple	9,0	16,0	35	35	39,0	35,0	EBU3M
	22,0 - 28,0	Triple	9,0	16,0	45	45	49,5	42,5	EBU34M
M40x1,5	14,0 - 24,0	Triple	9,0	18,0	35	45	49,5	35,0	EBU4SM
	22,0 - 32,0	Triple	9,0	18,0	45	45	49,5	42,5	EBU4M
	26,0 - 34,0	Triple	9,0	18,0	50	50	56,0	45,5	EBU45M
M50x1,5	22,0 - 32,0	Triple	9,0	18,0	45	55	61,0	42,5	EBU5SM
	26,0 - 35,0	Triple	9,0	18,0	50	55	61,0	45,5	EBU5M
	35,0 - 44,0	Triple	9,0	18,0	64	64	70,0	45,0	EBU56M
M63x1,5	26,0 - 35,0	Triple	9,0	18,0	50	68	75,0	45,5	EBU6SM
	35,0 - 45,0	Triple	9,0	18,0	64	68	75,0	45,0	EBU6M
	46,0 - 56,0	Triple	9,0	18,0	80	75	89,0	54,0	EBU67M
M75x1,5	35,0 - 45,0	Triple	9,0	20,0	64	80	89,0	45,0	EBU7SM
	46,0 - 62,0	Triple	9,0	20,0	80	80	89,0	54,0	EBU7M
	60,0 - 69,0	Triple	9,0	20,0	95	95	105,0	57,0	EBU78M
M90x1,5	46,0 - 62,0	Triple	9,0	20,0	80	95	105,0	53,5	EBU8SM
	60,0 - 75,0	Triple	9,0	20,0	95	95	105,0	57,0	EBU8M
	75,0 - 82,0	Triple	9,0	20,0	105	105	117,0	56,5	EBU810M
M100x1,5	60,0 - 75,0	Triple	9,0	20,0	95	105	117,0	57,0	EBU10SM
	75,0 - 85,0	Triple	9,0	20,0	105	105	117,0	56,0	EBU10M
M110x1,5	85,0 - 95,0	Triple	9,0	20,0	115	115	128,0	58,0	EBU11M
M115x2,0	75,0 - 85,0	Triple	9,0	24,0	105	130	144,0	56,0	EBU115XSM
	85,0 - 95,0	Triple	9,0	24,0	115	130	144,0	58,0	EBU115SM
	95,0 - 105,0	Triple	9,0	24,0	130	130	144,0	64,0	EBU115M
M130x2,0	105,0 - 115,0	Triple	9,0	24,0	140	140	154,0	67,5	EBU13M

Cable Glands for Non-armoured Cables

E-OCTANS

Technical Details		
Material	Body, Cap	Brass, Brass Nickel Plated, Stainless Steel 316L, Aluminium
	Seal	CR (Chloroprene), Silicone
	O-ring	CR (Chloroprene), Silicone
Ingress Protection Rating	IP 68 - 5 Bar, 30 min IP 66	
Operating Temperature	Seal Material	
	CR (Chloroprene)	Silicone
	Ex d/tb	-40°C to +80°C
Ex e/tb	-40°C to +80°C	
Equipment For	Gas & Dust potentially explosive atmospheres	
Suitable for use in	Group II	Gas Group IIC ZONE1/ZONE2
	Group III	Dust Group IIIC ZONE21/ZONE 22
	Equipment Marking	Ex II 2GD Ex db IIC Gb Ex eb IIC Gb Ex tb IIIC Db
Marking Example *	BMD EBU.. CE 0722  II 2GD Ex db IIC Gb Ex eb IIC Gb Ex tb IIIC Db Ta-40°C to +80°C IP66/68 IECEx CES 13.0006X CESI 13 ATEX 018X	
Thread Type	<ul style="list-style-type: none"> • Metric (M) ISO Pitch 1,5 • NPT (N) ANSI ASME B1.20.1 • Other thread types also available upon request. 	
Cable Type	Non Armoured	

Accessories	<ul style="list-style-type: none"> • Lock nuts • Gaskets (Washers) • Serrated Washers • Shrouds • Earth tags • Dome plugs
-------------	---

Remarks	<ul style="list-style-type: none"> • Accessories must be ordered separately. • O-ring available in Metric outer threads.
---------	--

Approvals	Certificate Number	Standards
	IMQ 13 ATEX 018X	EN 60079-0:2012+A11:2013 EN 60079-7:2015 EN 60079-31:2014 EN 60079-1:2014
	IECEx IMQ 13.0006X	IEC 60079-0:2011 Edition:6 IEC 60079-7:2015 Edition:5 IEC 60079-31:2013 Edition:2 IEC 60079-1:2014 Edition:7
	20150501-E474828	UL 2225, CAN/CSA-C22.2 No. 60079-0:11 CAN/CSA C22.2 No. 60079-7:12 CAN/CSA-C22.2 No. 60079-31:12
	20161226-E199260	UL 514B UL50E
	№ TC RU C-TR.AA87.B.00941	ГОСТ 31610.0-2014 ГОСТ IEC 60079-1:2013 ГОСТ IEC 60079-31:2013
	DNV 12.0052 X	ABNT NBR IEC 60079-0:2013 ABNT NBR IEC 60079-1:2009 ABNT NBR IEC 60079-7:2008 ABNT NBR IEC 60079-31:2011
	E-14044	IEC/EN60079-0 IEC/EN60079-7 IEC/EN60079-31 IEC/EN60079-1 IEC/EN 62444

-For more information see our webpage.
* The standard marking consists ATEX & IECEx only. Marking acc. to other standards on request.



Order Coding								
Part Number	Material	Seal	Gasket (Washer)	Seal Plug	Serrated Washer	Lock Nut	Shroud	Earth Tag
Mandatory	Mandatory	Mandatory	- Option	Option	Option	Option	Option	Option
See table	B Brass BN Brass Nickel plated X Stainless Steel 316L A Aluminium	C Chloroprene S Silicone	- WC Chloroprene WS Silicone WF Fiber	P Dome Plug	WSR Serrated washer	L Lock nut	S Shroud	E Earth tag
Example								
EBU1N (*BUE)	BN	S	- WC	P	WSR	L	S	E

* BUE: Part Number is valid for Customs Union certificate.

E-OCTANS

Cable Glands for Non-armoured Cables

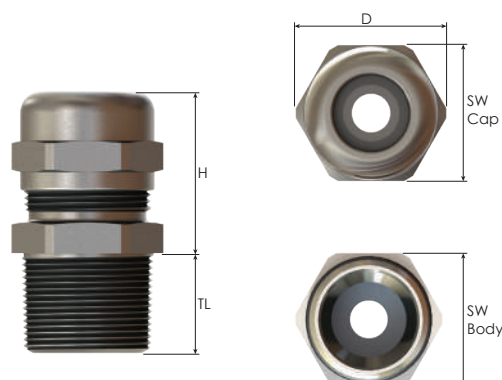







Thread Type **NPT** acc. to ANSI ASME B1.20.1

Outer Thread Size (Male)	Clamping Range		Outer Thread Length TL mm	Spanner Width		Outer Ø D mm	max. Height H mm	Part Number
	Ø min - max mm	Seal Type		SW Cap mm	SW Body mm			
NPT 1/4"	3,0 - 8,0	Double	16	20	20	22,0	29,0	EBU0N
	4,0 - 8,0	Triple	16	22	22	24,5	33,0	EBU0SN
NPT 3/8"	3,0 - 9,0	Double	16	20	20	22,0	29,0	EBU01SN
	4,0 - 12,0	Triple	16	22	22	24,5	33,0	EBU01N
NPT 1/2"	3,0 - 9,0	Double	16	20	22	24,5	29,0	EBU1SN
	4,0 - 12,0	Triple	16	22	22	24,5	29,0	EBU1N
	10,0 - 16,0	Triple	16	28	28	31,0	32,0	EBU12N
NPT 3/4"	4,0 - 12,0	Triple	16	22	28	31,0	29,0	EBU2SN
	10,0 - 18,0	Triple	16	28	28	31,0	32,0	EBU2N
	14,0 - 20,0	Triple	16	35	35	39,0	35,0	EBU23N
NPT 1"	10,0 - 18,0	Triple	20	28	35	39,0	32,5	EBU3SN
	14,0 - 24,0	Triple	20	35	35	39,0	35,0	EBU3N
	22,0 - 26,0	Triple	20	45	45	49,5	42,0	EBU34N
NPT 1 1/4"	14,0 - 24,0	Triple	20	35	45	49,5	35,0	EBU4SN
	22,0 - 32,0	Triple	20	45	45	49,5	42,5	EBU4N
	26,0 - 34,0	Triple	20	50	50	55,5	45,5	EBU45N
NPT 1 1/2"	22,0 - 32,0	Triple	20	45	55	61,0	42,5	EBU5SN
	26,0 - 35,0	Triple	20	50	55	61,0	45,5	EBU5N
	35,0 - 41,0	Triple	20	64	64	70,0	44,0	EBU56N
NPT 2"	26,0 - 35,0	Triple	20	50	68	75,0	45,5	EBU6SN
	35,0 - 45,0	Triple	20	64	68	75,0	45,0	EBU6N
	46,0 - 52,0	Triple	20	80	75	89,0	54,0	EBU67N
NPT 2 1/2"	35,0 - 45,0	Triple	21	64	80	89,0	45,0	EBU7SN
	46,0 - 62,0	Triple	21	80	80	89,0	53,5	EBU7N
	60,0 - 64,0	Triple	21	95	95	105,0	57,0	EBU78N
NPT 3"	46,0 - 62,0	Triple	21	80	95	105,0	53,5	EBU8SN
	60,0 - 75,0	Triple	21	95	95	105,0	57,0	EBU8N
	75,0 - 79,5	Triple	21	105	105	117,0	56,0	EBU810N
NPT 4"	60,0 - 75,0	Triple	21	95	115	128,0	57,0	EBU108N
	75,0 - 85,0	Triple	21	105	115	128,0	56,0	EBU10N
	85,0 - 95,0	Triple	21	115	115	128,0	58,0	EBU11N
	95,0 - 101,0	Triple	21	130	130	144,0	64,5	EBU115N
NPT 5"	95,0 - 105,0	Triple	27	130	145	162,0	64,5	EBU13N
	105,0 - 115,0	Triple	27	140	145	162,0	67,5	EBU130N

Cable Glands for Non-armoured Flat Cables

E-OCTANS FLAT

Technical Details	
Material	Body, Cap Brass, Brass Nickel Plated, Stainless Steel, Aluminium Seal CR (Chloroprene), Silicone O-ring CR (Chloroprene), Silicone
Ingress Protection Rating	IP 68 - 5 Bar, 30 min IP 66
Operating Temperature	Seal Material CR (Chloroprene) -40°C to +80°C Silicone -60°C to +80°C
Ex d/tb	-40°C to +80°C
Ex e/tb	-40°C to +80°C
Equipment For	Gas & Dust potentially explosive atmospheres
Suitable for use in	Group II Gas Group IIC ZONE1/ZONE2 Group III Dust Group IIIC ZONE21/ZONE 22
Equipment Marking	Ex II 2GD Ex db IIC Gb Ex eb IIC Gb Ex tb IIIC Db
Marking Example *	BMD EBU.. CE 0722  II 2GD Ex db IIC Gb Ex eb IIC Gb Ex tb IIIC Db Ta-40°C to +80°C IP66/68 IECEX CES 13.0006X CESI 13 ATEX 018X
Thread Type	<ul style="list-style-type: none"> • Metric (M) ISO Pitch 1,5 • NPT (N) ANSI ASME B1.20.1 • Other thread types also available upon request.
Cable Type	Flat form non armoured cable
Accessories	<ul style="list-style-type: none"> • Lock nuts • Gaskets (Washers) • Serrated Washers • Shrouds • Earth tags • Dome plugs
Remarks	<ul style="list-style-type: none"> • Accessories must be ordered separately. • O-ring available in Metric outer threads.
Approvals	Certificate Number Standards
	IMQ 13 ATEX 018X EN 60079-0:2012+A11:2013 EN 60079-7:2015 EN 60079-31:2014 EN 60079-1:2014
	IECEX IMQ 13.0006X IEC 60079-0:2011 Edition:6 IEC 60079-7:2015 Edition:5 IEC 60079-31:2013 Edition:2 IEC 60079-1:2014 Edition:7
	№ TC RU C-TR.AA87.B.00941 GOCT 31610.0-2014 GOCT IEC 60079-1:2013 GOCT IEC 60079-31:2013
	DNV 12.0052 X ABNT NBR IEC 60079-0:2013 ABNT NBR IEC 60079-1:2009 ABNT NBR IEC 60079-7:2008 ABNT NBR IEC 60079-31:2011
	E-14044 IEC/EN60079-0 IEC/EN60079-7 IEC/EN60079-31 IEC/EN60079-1 IEC/EN 62444
-For more information see our webpage. * The standard marking consists ATEX & IECEX only. Marking acc. to other standards on request.	



Order Coding								
Part Number	Material	Seal	- Gasket (Washer)	Serrated Washer	Lock Nut	Shroud	Earth Tag	For Ex e
Mandatory	Mandatory	Mandatory	- Option	Option	Option	Option	Option	Option
See table	B Brass BN Brass, Nickel plated X Stainless Steel 316L A Aluminium	C Chloroprene S Silicone	- WC Chloroprene WS Silicone WF Fiber	WSR Serrated washer	L Lock nut	S Shroud	E Earth tag	TL 9
Example								
EBU1N(FxC1)	BN	S	- WC	-	L	-	E	TL 9

E-OCTANS FLAT

Cable Glands for Non-armoured Cables

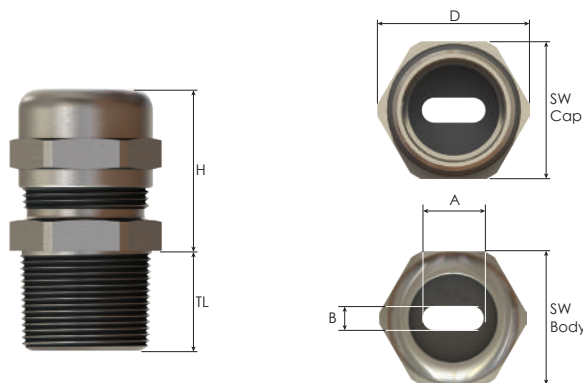

Thread Type **METRIC** acc. to ISO 965-3

Outer Thread Size (Male)	Flat Hole		Outer Thread Length		Spanner Width		Outer Ø	max.Height	Part Number
	Height B mm	Width A mm	Ex-e min.	Ex-d/e min.	Cap	Body			
					SW Cap mm	SW Body mm			
M20X1,5	5,0	12,2	9,0	16,0	22	22	24,5	29,0	EBU1M(FxA1)
	5,5	11,7	9,0	16,0	22	22	24,5	29,0	EBU1M(FxC1)
	6,0	8,5	9,0	16,0	22	22	24,5	29,0	EBU1M(FxB1)
	6,0	12,2	9,0	16,0	22	22	24,5	29,0	EBU1M(FxD1)
	6,3	10,8	9,0	16,0	22	22	24,5	29,0	EBU1M(FxE1)
	6,7	12,7	9,0	16,0	22	22	24,5	29,0	EBU1M(FxG1)
M25X1,5	5,0	12,8	9,0	16,0	28	28	31,0	32,5	EBU2M(FxA2)
	5,5	10,7	9,0	16,0	28	28	31,0	32,5	EBU2M(FxH2)
	5,5	11,7	9,0	16,0	28	28	31,0	32,5	EBU2M(FxC2)
	6,0	8,5	9,0	16,0	28	28	31,0	32,5	EBU2M(FxB2)
	6,0	14,0	9,0	16,0	28	28	31,0	32,5	EBU2M(FxD2)
	7,3	13,3	9,0	16,0	28	28	31,0	32,5	EBU2M(FxF2)
	6,8	15,3	9,0	16,0	28	28	31,0	32,5	EBU2M(FxG2)
	9,1	12,3	9,0	16,0	28	28	31,0	32,5	EBU2M(FxE2)

Thread Type **NPT** acc. to ANSI ASME B1.20.1

Outer Thread Size (Male)	Flat Hole		Outer Thread Length	Spanner Width		Outer Ø	max.Height	Part Number
	Height B mm	Width A mm		Cap	Body			
			TL mm	SW Cap mm	SW Body mm			
NPT 1/2"	5,0	12,2	16,0	22	22	24,5	29,0	EBU1N(FxA1)
	5,5	11,7	16,0	22	22	24,5	29,0	EBU1N(FxC1)
	6,0	8,5	16,0	22	22	24,5	29,0	EBU1N(FxB1)
	6,0	12,2	16,0	22	22	24,5	29,0	EBU1N(FxD1)
	6,3	10,8	16,0	22	22	24,5	29,0	EBU1N(FxE1)
	6,7	12,7	16,0	22	22	24,5	29,0	EBU1N(FxG1)
NPT 3/4"	5,0	12,8	16,0	28	28	31,0	32,0	EBU2N(FxA2)
	5,5	10,7	16,0	28	28	31,0	32,0	EBU2N(FxH2)
	5,5	11,7	16,0	28	28	31,0	32,0	EBU2N(FxC2)
	6,0	8,5	16,0	28	28	31,0	32,0	EBU2N(FxB2)
	6,0	14,0	16,0	28	28	31,0	32,0	EBU2N(FxD2)
	6,8	15,3	16,0	28	28	31,0	32,0	EBU2N(FxG2)
	7,3	13,3	16,0	28	28	31,0	32,0	EBU2N(FxF2)
	9,1	12,3	16,0	28	28	31,0	32,0	EBU2N(FxE2)

Cable Glands for Non-armoured Cables

CRATER



Technical Details		
Material	Body, Cap	Brass, Brass Nickel Plated, Stainless Steel 316L, Aluminium
	Inner Part	Brass, Brass Nickel Plated, Stainless Steel 316L, Aluminium
	Seal	CR (Chloroprene), Silicone
	O-ring	CR (Chloroprene), Silicone
Ingress Protection Rating	IP 68 - 5 Bar, 30 min IP 66	
Operating Temperature	Seal Material	
Ex d/e/tb	CR (Chloroprene)	-40°C to +100°C
	Silicone	-60°C to +130°C
Equipment For	Gas & Dust potentially explosive atmospheres	
Suitable for use in	Group II	Gas Group IIC ZONE1/ZONE2
	Group III	Dust Group IIIC ZONE21/ZONE 22
Equipment Marking	Ex II 2GD Ex d IIC Gb Ex e IIC Gb Ex tb IIIC Db	
Marking Example *	BMD KBU.. CE 0722 IIIGD Ex db IIC Gb Ex eb IIC Gb Ex tb IIIC Db Ta -40°C to +80°C IP66/68 CESI 13 ATEX 033X IECEx CES 13.0013X	
Thread Type	<ul style="list-style-type: none"> • Metric (M) ISO Pitch 1,5 • NPT (N) ANSI ASME B1.20.1 • Other thread types also available upon request. 	
Cable Type	Non Armoured	
Accessories	<ul style="list-style-type: none"> • Lock nuts • Gaskets (Washers) • Serrated Washers • Earth tags 	
Remarks	<ul style="list-style-type: none"> • Accessories must be ordered separately. • O-ring available in Metric outer threads. 	
Approvals	Certificate Number	Standards
	CESI 13 ATEX 033X	EN 60079-0:2012+A11:2013 EN 60079-1:2007 EN 60079-7:2007 EN 60079-31:2009
	IECEx CES 13.0013X	IEC 60079-0:2011 Edition:6.0 IEC 60079-1:2007-04 Edition:6.0 IEC 60079-31:2008 Edition:1 IEC 60079-7:2006-07 Edition:4
	№ TC RU C-TR.AA87.B.00941	ГОСТ 31610.0-2014 ГОСТ IEC 60079-1:2013 ГОСТ IEC 60079-31:2013
	DNV 12.0053 X	ABNT NBR IEC 60079-0:2013 ABNT NBR IEC 60079-1:2009 ABNT NBR IEC 60079-7:2008 ABNT NBR IEC 60079-31:2011
	E-14044	IEC/EN60079-0 IEC/EN60079-7 IEC/EN60079-31 IEC/EN60079-1 IEC/EN 62444
	MASC MS/18-0240X	SANS (IEC) 60079-0 : 2011 SANS (IEC) 60079-1 : 2014 SANS (IEC) 60079-7 : 2007 SANS (IEC) 60079-31 : 2014
-For more information see our webpage.		
* The standard marking consists ATEX & IECEx only. Marking acc. to other standards on request.		



Order Coding						
Part Number	Material	Seal	-	Gasket (Washer)	Serrated Washer	Lock Nut
	Mandatory	Mandatory	-	Option	Option	Option
See table	B Brass BN Brass Nickel plated X Stainless steel A Aluminium	C Chloroprene S Silicone	-	WC Chloroprene WS Silicone WF Fiber	WSR Serrated washer	L Lock nut
Example			-			
KBU5N	BN	S	-	WC	WSR	L E

CRATER

Cable Glands for Non-armoured Cables

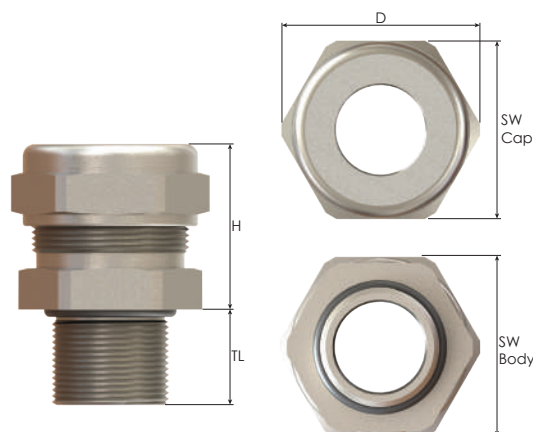





Thread Type METRIC acc. to ISO 965-3								
Outer Thread Size (Male)	Clamping Range Ø min-max mm	Outer Thread Length TL mm	Spanner Width		Outer Ø D mm	max. Height		Part Number
			Cap SW Cap mm	Body SW Body mm		H mm		
M16x1,5	3,0 - 8,5	16,0	26	22	29,0	27,0	KBU01M	
	6,0 - 12,0	16,0	29	25	31,5	30,0	KBU01LM	
M20x1,5	6,0 - 12,0	16,0	29	25	31,5	29,5	KBU1M	
	12,0 - 14,5	16,0	30	28	33,5	30,0	KBU1LM	
M25x1,5	6,0 - 12,0	18,0	29	29	31,5	30,5	KBU2SM	
	12,0 - 16,0	18,0	34	32	37,0	30,5	KBU2M	
	12,0 - 20,0	18,0	40	36	44,5	34,5	KBU2LM	
M32x1,5	12,0 - 20,0	18,0	40	40	44,5	35,5	KBU3SM	
	15,0 - 26,0	18,0	52	48	57,0	42,5	KBU3M	
M40x1,5	15,0 - 26,0	18,0	52	48	57,0	42,5	KBU4SM	
	20,0 - 32,0	18,0	60	55	66,0	52,0	KBU4M	
M50x1,5	22,0 - 35,0	18,0	70	60	77,0	52,0	KBU5SM	
	27,0 - 41,0	18,0	70	70	77,0	55,5	KBU5M	
M63x1,5	35,0 - 45,0	20,0	80	75	89,5	63,5	KBU6SM	
	40,0 - 52,0	20,0	85	85	94,0	63,5	KBU6M	
M75x1,5	40,0 - 52,0	20,0	85	85	94,0	63,5	KBU7SM	
	45,0 - 60,0	20,0	95	90	105,0	73,5	KBU7M	
M90x1,5	45,0 - 60,0	20,0	95	95	105,0	73,5	KBU8SM	
	60,0 - 72,0	20,0	115	110	127,0	85,5	KBU8M	

Thread Type NPT acc. to ANSI ASME B1.20.1								
Outer Thread Size (Male)	Clamping Range Ø min-max mm	Outer Thread Length TL mm	Spanner Width		Outer Ø D mm	max. Height		Part Number
			Cap SW Cap mm	Body SW Body mm		H mm		
NPT 3/8"	3,0 - 8,5	16,0	26	22	29,0	27,0	KBU01N	
	6,0 - 12,0	16,0	29	25	31,5	30,0	KBU01LN	
NPT 1/2"	6,0 - 12,0	21,0	29	25	31,5	29,0	KBU1N	
	12,0 - 14,5	21,0	30	28	33,5	30,0	KBU1LN	
NPT 3/4"	6,0 - 12,0	21,0	29	29	31,5	30,5	KBU2SN	
	12,0 - 16,0	21,0	34	32	37,0	30,5	KBU2N	
NPT 1"	12,0 - 20,0	21,0	40	36	44,5	34,0	KBU2LN	
	15,0 - 26,0	26,0	40	40	44,5	35,5	KBU3SN	
NPT 1 1/4"	15,0 - 26,0	26,0	52	48	57,0	42,0	KBU3N	
	20,0 - 32,0	28,0	52	48	57,0	44,0	KBU4SN	
NPT 1 1/2"	20,0 - 32,0	28,0	60	55	66,0	52,0	KBU4N	
	22,0 - 35,0	28,0	70	60	77,0	52,0	KBU5SN	
NPT 2"	27,0 - 41,0	28,0	70	70	77,0	55,5	KBU5N	
	35,0 - 45,0	28,0	80	75	89,5	63,0	KBU6SN	
NPT 2 1/2"	40,0 - 52,0	28,0	85	85	94,0	63,5	KBU6N	
	40,0 - 52,0	41,0	85	85	94,0	63,5	KBU7SN	
NPT 3"	45,0 - 60,0	41,0	95	90	105,0	73,5	KBU7N	
	45,0 - 60,0	43,0	95	95	105,0	73,5	KBU8SN	
	60,0 - 72,0	43,0	115	110	127,0	85,5	KBU8N	

Barrier Cable Glands for Non-armoured Cables

CENTAURUS-N

Technical Details			
Material	Body, Cap	Brass, Brass Nickel Plated, Stainless Steel 316L	
	Inner Part	Brass, Brass Nickel Plated, Stainless Steel 316L	
Ingress Protection Rating	Seal	Silicone	
		IP 68 - 5 Bar, 30 min IP 66	
Operating Temperature	Seal Material	Silicone	
		-60°C to +60°C	
Service Temperature	Seal Material	Silicone	
		-60°C to +100°C	
Equipment For	Gas & Dust potentially explosive atmospheres		
Suitable for use in	Group II	Gas Group IIC	ZONE1/ZONE2
	Group III	Dust Group IIIC	ZONE21/ZONE 22
Equipment Marking	Ex II 2GD - Ex d IIC Gb Ex e IIC Gb Ex tb IIIC Db		
Marking Example *	BMD KBCTN.. CE 0722  II 2GD Ex db IIC Gb Ex eb IIC Gb Ex tb IIIC Db Ta -60°C to +60°C IP66/68 CESI 17 ATEX 007X IECEx CES 17.0029X		
Thread Type	<ul style="list-style-type: none"> • Metric (M) ISO Pitch 1,5 • NPT (N) ANSI ASME B1.20.1 • Other thread types also available upon request. 		
Cable Type	Non Armoured		
Accessories	<ul style="list-style-type: none"> • Lock nuts • Gaskets (Washers) • Serrated Washers • Shrouds • Earth tags 		
	<ul style="list-style-type: none"> • O-ring available in Metric outer threads. • Accessories must be ordered separately. 		
Remarks			
Approvals	Certificate Number	Standards	
	CESI 17 ATEX 0007X	EN 60079-0:2012+A11:2013 EN 60079-1:2014 EN 60079-7:2015 EN 60079-31:2014	
	IECEx CES 17.0029X	IEC 60079-0:2011 Edition:6 IEC 60079-1:2014 Edition:7 IEC 60079-31:2013 Edition:2 IEC 60079-7:2015-08 Edition:5	
	№ TC RU C-TR.AA87.B.00941	ГОСТ 31610.0-2014 ГОСТ IEC 60079-1:2013 ГОСТ IEC 60079-31:2013	
-For more information see our webpage.			
* The standard marking consists ATEX & IECEx only. Marking acc. to other standards on request.			

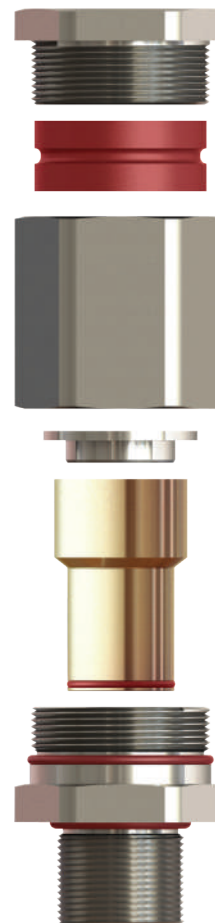

Order Coding							
Part Number	Material	Seal	Gasket (Washer)	Serrated Washer	Lock Nut	Shroud	Earth Tag
Mandatory	Mandatory	Mandatory	- Option	Option	Option	Option	Option
See table	B Brass BN Brass Nickel plated X Stainless Steel 316L	S Silicone	- WS Silicone WF Fiber	WSR Serrated washer	L Lock nut	S Shroud	E Earth tag
Example							
KBACTN5N	BN	S	- Ws	-	L	-	E

CENTAURUS-N Barrier Cable Glands for Non-Armoured Cables

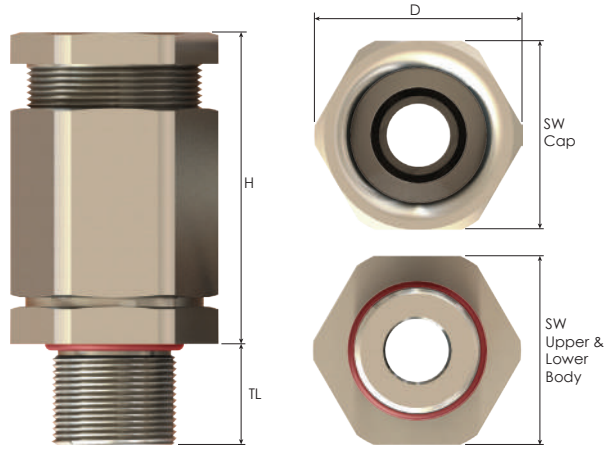

Thread Type **METRIC** acc. to ISO 965-3

Outer Thread Size (Male)	Clamping Range Ø min-max mm	Over Conductors max Ø mm	Outer Thread Length TL mm	Spanner Width			Outer Ø D mm	max. Height H mm	Part Number	Need Barrier Compound Material Per Pcs. (g)
				Cap SW Cap mm	Upper Body SW Upper Body mm	Lower Body SW Lower Body mm				
M20x1,5	6,0 - 13,0	9,5	16,0	25	25	25	27,0	51,0	KBCTN1SM	7
	8,0 - 15,0	9,5	16,0	25	25	25	27,0	51,0	KBCTN1M	7
	13,5 - 21,0	12,0	16,0	30	30	30	33,0	52,5	KBCTN1LM	6
M25x1,5	8,0 - 15,0	9,5	16,0	25	25	30	33,0	51,0	KBCTN2SM	7
	13,5 - 21,0	12,0	16,0	30	30	30	33,0	52,5	KBCTN2M	6
	18,0 - 27,0	15,0	16,0	40	40	40	44,5	60,0	KBCTN2LM	14
M32x1,5	18,0 - 27,0	15,0	16,0	40	40	40	44,5	60,0	KBCTN3M	14
	23,0 - 33,0	21,5	16,0	43	43	43	47,0	61,5	KBCTN3LM	26
M40x1,5	23,0 - 33,0	21,5	16,0	43	43	45	50,0	61,5	KBCTN4SM	26
	29,0 - 40,0	29,0	16,0	50	50	50	55,5	69,5	KBCTN4M	50
M50x1,5	29,0 - 40,0	29,0	16,0	50	50	55	61,0	69,5	KBCTN5SM	50
	35,0 - 48,0	37,0	16,0	58	58	58	64,0	75,0	KBCTN5M	82
M63x1,5	35,0 - 48,0	37,0	20,0	58	58	68	75,0	75,0	KBCTN6SM	82
	42,0 - 56,0	46,0	20,0	75	75	75	83,0	97,5	KBCTN6M	180
M75x1,5	42,0 - 56,0	46,0	20,0	75	75	80	89,0	97,5	KBCTN7SM	180
	54,0 - 70,0	58,0	20,0	100	100	100	110,5	106,5	KBCTN7M	290
M90x1,5	54,0 - 70,0	58,0	20,0	100	100	100	110,5	106,5	KBCTN8M	290

*Barrier compound is served as 50 g standard.

Thread Type **NPT** acc. to ANSI ASME B1.20.1

Outer Thread Size (Male)	Clamping Range Ø min-max mm	Over Conductors max Ø mm	Outer Thread Length TL mm	Spanner Width			Outer Ø D mm	max. Height H mm	Part Number	Need Barrier Compound Material Per Pcs. (g)
				Cap SW Cap mm	Upper Body SW Upper Body mm	Lower Body SW Lower Body mm				
NPT 1/2"	6,0 - 13,0	9,5	21,0	25	25	25	27,0	51,0	KBCTN1SN	7
NPT 1/2"	8,0 - 15,0	9,5	21,0	25	25	25	27,0	51,0	KBCTN1N	7
	13,5 - 21,0	12,0	21,0	30	30	30	33,0	52,5	KBCTN1LN	6
	8,0 - 15,0	9,5	21,0	25	25	30	33,0	51,0	KBCTN2SN	7
NPT 3/4"	13,5 - 21,0	12,0	21,0	30	30	30	33,0	52,5	KBCTN2N	6
	18,0 - 27,0	15,0	21,0	40	40	40	44,5	60,0	KBCTN2LN	14
	18,0 - 27,0	15,0	26,0	40	40	40	44,5	60,0	KBCTN3N	14
NPT 1"	23,0 - 33,0	21,5	26,0	43	43	43	47,0	61,5	KBCTN3LN	26
	23,0 - 33,0	21,5	28,0	43	43	45	50,0	61,5	KBCTN4SN	26
NPT 1 1/4"	29,0 - 40,0	29,0	28,0	50	50	50	55,5	69,5	KBCTN4N	50
NPT 1 1/2"	29,0 - 40,0	29,0	28,0	50	50	55	61,0	69,5	KBCTN5N	50
NPT 2"	35,0 - 48,0	37,0	28,0	58	58	65	72,0	75,0	KBCTN6N	82
NPT 2 1/2"	42,0 - 56,0	46,0	41,0	75	75	80	89,0	97,5	KBCTN7N	180
NPT 3"	54,0 - 70,0	58,0	43,0	100	100	100	110,5	106,5	KBCTN8N	290

*Barrier compound is served as 50 g standard.

VENTILATION AND DRAIN PRODUCTS for Gas & Dust Application



Hydra, Ventilation Plugs
Virgo, Drain Plugs

198 - 199
200 - 201

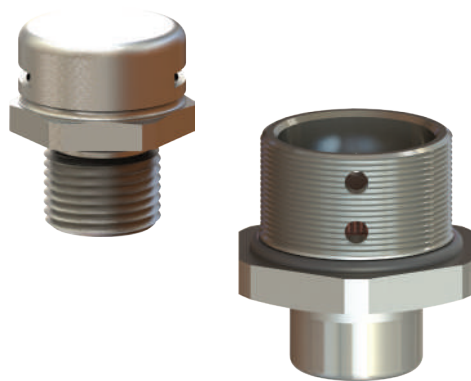

Ventilation and Drain Products / Group II-III / Gas & Dust

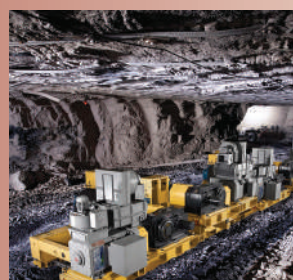

In order to choose the right ventilation plug unit (pressure balance elements) for a specific application, the working principles of the unit must be known first. Ventilation plugs are permeable to "gases and vapours, e.g. air" but impermeable to "liquids and dust, e.g. water". The permeability resistance to liquids depends on the pore size and structure of the membrane inside these devices.

If the working conditions of water (the most common liquid) are studied, it is possible to say that the water intrusion pressure goes down as air permeability increases. The relevant specifications are collected in tabulated data.

Of the relevant parameters, the "Pressure Balance" function depends on the differential pressure between the inner and the outer environments of the enclosure. As a reference pressure, 70 mBar (70mBar = 1 Psi) value is chosen to present data. Under normal conditions, air circulation exists for all differential pressure levels. But the volume flow rate is very low for smaller values and obviously increases with increasing pressure values. Of course the air flow rate also depends on the properties of the membrane (classified as standard, medium, high and ultra high permeability types).

If there is no water pressure danger (if the device is not immersed in the water), it is always better to choose highly permeable elements for good circulation even for low differential pressure levels.

In essence, there is air circulation in the enclosure from the inside to the outside when the device is heating up due to its operation. Similarly, a circulation in reverse direction occurs during the cooling period. It should also be noted that there is always a level of humidity in air, hence some water in the form of vapour is also circulated with air. However condensed water is blocked by the water repellent membrane unless the differential pressure exceeds the intrusion pressure threshold.

After this technical overview, the utility of the "Ventilation Plugs" can be listed as follows;

- Prevention of pressure increase inside the enclosure. The pressure sensitive elements are not threatened.
- Limiting of temperature increase by the air circulation. The temperature sensitive elements are not threatened.
- Added flexibility for maintenance. In traditional units, when the enclosures are heated, generally the dilated air goes out from the seals but can not return back when the device is colder. Because of the vacuum formed inside the enclosure, the gaskets are exposed to large pressure levels. In result, it is very difficult to open the covers for maintenance. Especially in "luminaires" it is obligatory to change the bulbs when the device is cold. The ventilation plugs in our system prevent these kind of limitations.
- Prevention of accidental water suction into the system. During the cooling period, we know that there is air circulation from the outside to the inside. Hence, if the enclosure is wet from rain or due to other reasons, some water may be sucked inside the enclosure if there is no ventilation plug.
- Prevention of exposure to hot, humid, compressed gases. There is always a level of humidity in the enclosure due to atmospheric conditions. Hence when the device is hot, all the components will be exposed to a hot, humid and compressed environment without the ventilation plug.

To conclude, the ventilation plug can reduce and even fully eliminate the adverse effects of humidity in the environment. Water drops on the bottom of the enclosure are normal, but the inherent damage becomes insignificant due to the existence of a ventilation plug.

Ventilation plugs for Ex e applications

Ventilation Plugs

- Balances pressure differences between inside and outside of enclosure.
- Prevents damages, such as condensation due to pressure differences.
- Membrane properties: hydrophobic, oleophobic.

Technical Details

Body ,Cap	Stainless Steel 316L		
Material	Vent. Membrane	Acrylic co-polymer on nylon-support	
	O-ring	CR (Chloroprene)	
Ingress Protection Rating	IP 66 (EN 60529)		
Operating Temperature	Seal Material		
	CR (Chloroprene)		
Ex e/tb	-40°C to +100°C		
Equipment For	• Gas & Dust potentially explosive atmospheres.		
Suitable for use in	Group II	Gas Group IIC	ZONE1 /ZONE2
	Group III	Dust Group IIIC	ZONE21 /ZONE 22
Equipment Marking	Ex II 2GD Ex e IIC Gb Ex † IIIC Db		
Marking Example *	RST DAE... 0637 Ex II 2G Ex e IIC Gb Ex II 2D Ex † IIIC Db IExU 10 ATEX 1169 U		
Type Protection	Ex e ; Ex †		
Thread Type	• Metric (M) ISO Pitch 1,5		
Remarks	• O-ring available in Metric outer threads.		
Approvals	Certificate Number	Standards	



IBExU 10 ATEX 1169 U

EN 60079-0:2009
EN 60079-7:2007
EN 60079-31:2009



№ TC RU C-TR.AA87.B.00941

ГОСТ 31610.0-2014
ГОСТ IEC 60079-1:2013
ГОСТ IEC 60079-31:2013

-For more information see our webpage.

* The standard marking consists ATEX & IECEx only. Marking acc. to other standards on request.

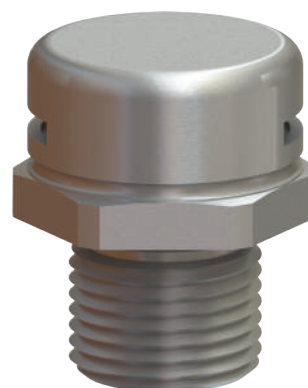

HYDRA

Ventilation Plugs for Ex e applications

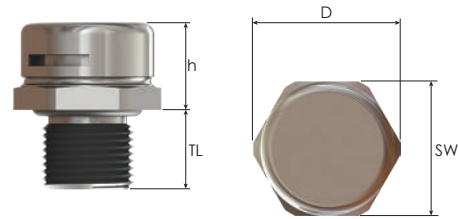

Thread Type **METRIC** acc. to ISO 965-3

Outer Thread Size (Male)	Average Air Flow $\Delta P=70$ mBar / 1 psi	Water Intrusion Pressure bar	Outer Thread Length	Spanner Width	Outer \varnothing D mm	Height	Part Number
	l/h		TL mm	SW mm		h mm	
M12x1,5	16	0,9	6,0	17	18,8	11,0	SBBVP-X01
	16	0,9	10,0	17	18,8	11,0	SBBVP-X01L
	25	0,5	6,0	17	18,8	11,0	MBBVP-X01
	25	0,5	10,0	17	18,8	11,0	MBBVP-X01L
	120	0,2	6,0	17	18,8	11,0	HBBVP-X01
	120	0,2	10,0	17	18,8	11,0	HBBVP-X01L
	300	0,1	6,0	17	18,8	11,0	UHHBVP-X01
	300	0,1	10,0	17	18,8	11,0	UHHBVP-X01L

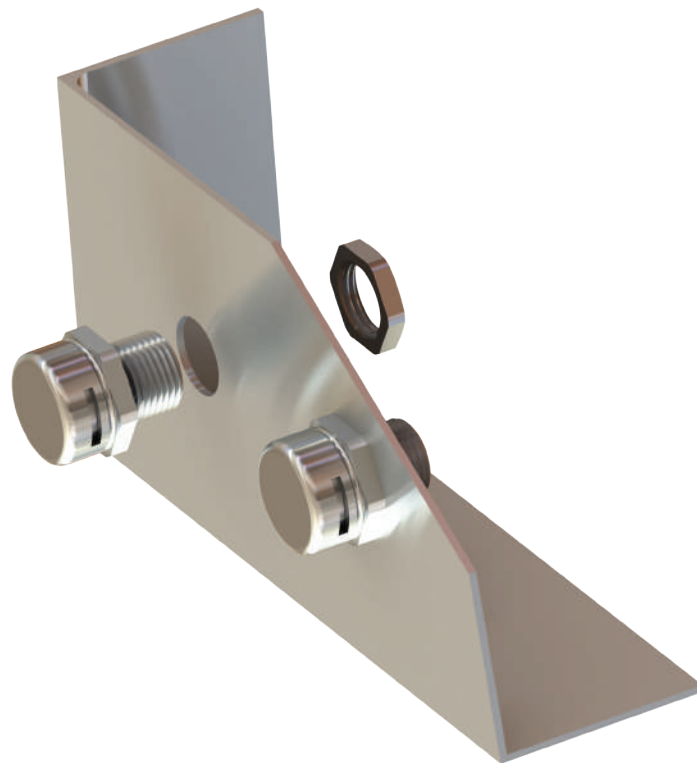



Drain plugs for Ex e application

Drain Plug

- Effectively draining moisture out off an enclosure.
- Prevents damages, such as condensation water.
- Allows the air inside the enclosure to breathe with the surrounding atmosphere.

Technical Details

Material	Body ,Cap	Brass, Brass Nickel Plated, Stainless Steel 316L
	Membrane	Bronze
	O-Ring	Silicone
Ingress Protection Rating		IP 66
Operating Temperature	Seal Material	Silicone
Ex e/tb		-60°C to +85°C
Equipment For	• Gas & Dust potentially explosive atmospheres.	
Suitable for use in	Group II	Gas Group IIC ZONE1/ZONE2
	Group III	Dust Group IIIC ZONE21/ZONE 22
Equipment Marking	Ex II 2GD Ex eb IIC Gb Ex tb IIIC Db IP66	
Marking Example *	BMD BDRV... CE 0722 Ex II 2GD Ex eb IIC Gb Ex tb IIIC Db Ta -60°C to +85°C IP66 IMQ 13 ATEX 030X IECEx IMQ 14.0003X	
Type Protection	Ex eb ; Ex tb	
Thread Type	• Metric (M) ISO Pitch 1,5 • Npt (N) ANSI ASME B1.20.1	
Accessories	• Lock Nut	
Remarks	• O-ring available in Metric outer threads. • Accessories must be ordered separately.	

Approvals	Certificate Number	Standards
	IMQ 13 ATEX 030X	EN 60079-0:2012+A11:2013 EN 60079-7:2015 EN 60079-31:2014
	IECEx IMQ 14.0003X	IEC 60079-0:2011 Edition:6 IEC 60079-31:2013 Edition:2 IEC 60079-7:2015 Edition:5
	№ TC RU C-TR.AA87.B.00941	ГОСТ 31610.0-2014 ГОСТ IEC 60079-1:2013 ГОСТ IEC 60079-31:2013

-For more information see our webpage.

* The standard marking consists ATEX & IECEx only. Marking acc. to other standards on request.

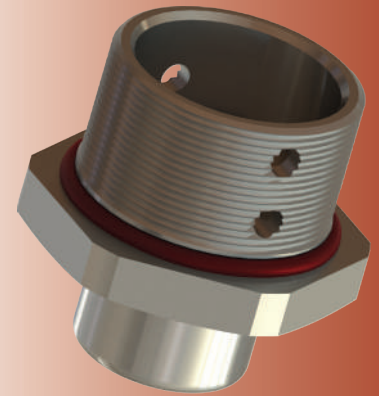

Threaded Hole

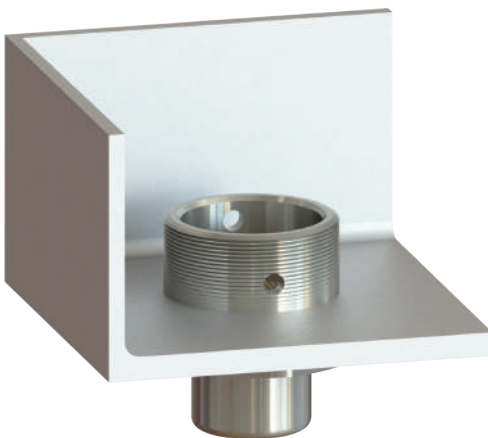

Non-Threaded Hole

Special Lock Nut
for Drain Plug

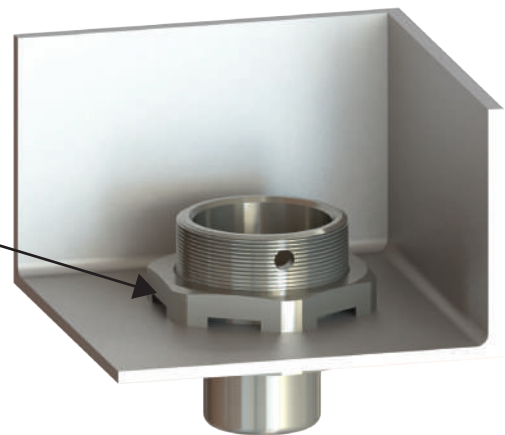

Order Coding				
Part Number	Material	Seal	-	Lock Nut
Mandatory	Mandatory	Mandatory	-	Option
See table	B Brass BN Brass Nickel Plated X Stainless steel 316L	S Silicone	-	L Lock Nut
Example				
BDRV-1M	BN		-	

VIRGO

Drain Plugs Ex e applications

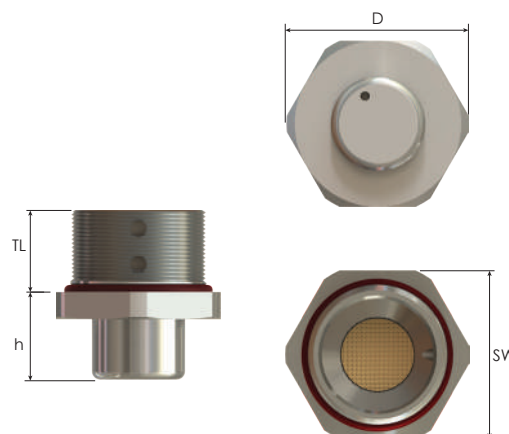

Thread Type METRIC acc. to ISO 965-3					
Outer Thread Size (Male)	Outer Thread Length	Spanner Width	Outer Ø	Height	Part Number
	TL mm	SW mm	D2 mm	h mm	
M20x1,5	15,0	25	27,5	16,0	BDRV-1M
M25x1,5	15,0	30	33,0	16,0	BDRV-2M

Thread Type NPT acc. to ANSI ASME B1.20.1					
Outer Thread Size (Male)	Outer Thread Length	Spanner Width	Outer Ø	Height	Part Number
	TL mm	SW mm	D2 mm	h mm	
NPT 1/2"	16,0	25	27,5	16,0	BDRV-1N
NPT 3/4"	16,0	30	33,0	16,0	BDRV-2N

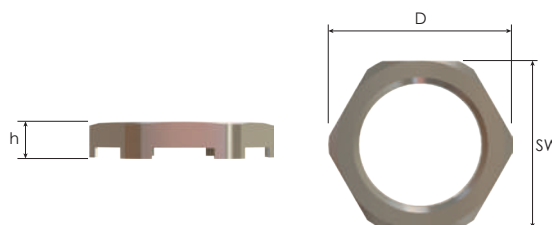
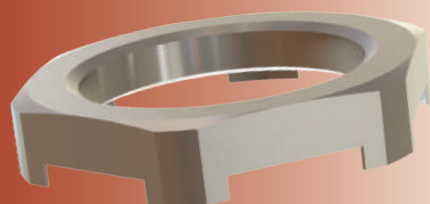

Special Lock Nuts for Drain Plugs

Inner Thread Size (Female)	Spanner Width	Outer Ø	Height	Part Number
	SW mm	D2 mm	h mm	
M20x1,5	25	27,5	5,0	BDRL-03
M25x1,5	30	33,0	5,0	BDRL-04
NPSL 1/2"	25	27,5	5,0	BDRLN-03
NPSL 3/4"	30	33,0	5,0	BDRLN-04

bimed

FITTINGS FOR RIGID CONDUITS WITH NON-ARMOURED CABLES for Gas & Dust Application

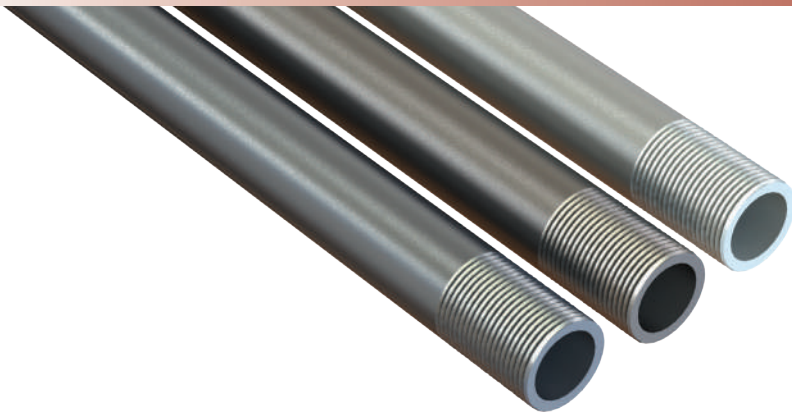

E-Carina, Straight Conduit Fittings

E-Carina Flat, Straight Conduit Fittings

E-Cygnus, Swivel Conduit Fittings

Phoenix, Multihole Swivel Conduit Fittings

204 - 207

208 - 211

212 - 215

216 - 217

Ex Glands / Group II-III / Gas & Dust



Despite the similarity to pipes used in plumbing, purpose-designed electrical fittings are used to connect conduit. Box connectors join conduit to a junction box or other electrical box. A typical box connector is inserted into a knockout in a junction box, with the threaded end then being secured with a ring (called a lock nut) from within the box, as a bolt would be secured by a nut. The other end of the fitting usually has a screw or compression ring which is tightened down onto the inserted conduit.







Fittings for non-threaded conduits are either secured with set screws or with a compression nut that encircles the conduit. Fittings for general purpose use with metal conduits may be made of die-cast zinc, but where stronger fittings are needed, they are made of copper-free aluminum or cast iron.

Sometimes the fittings are considered sufficiently conductive to bond (electrically unite) the metal conduit to a metal junction box (thus sharing the box's ground connection); other times, grounding bushings are used which have bonding jumpers from the bushing to a grounding screw on the box. Unlike water piping, if it the conduit is to be watertight, the idea is to keep water out, not in. In this case, gaskets are used with special fittings, such as the weatherhead leading from the overhead electrical mains to the electric meter.

Rigid Conduit Fittings for Ex d/e applications

E-CARINA



Technical Details		
Material	Body	Brass, Brass Nickel Plated, Stainless Steel 316L, Aluminium
	Seal	CR (Chloroprene), Silicone
	O-ring	CR (Chloroprene), Silicone
Ingress Protection Rating	IP 68 - 5 Bar, 30 min IP 66	
Operating Temperature	Seal Material	
	CR (Chloroprene)	Silicone
Ex d/tb	-40°C to +80°C	-60°C to +80°C
Ex e/tb	-40°C to +80°C	-60°C to +140°C
Equipment For	Gas & Dust potentially explosive atmospheres	
Suitable for use in	Group II	Gas Group IIC ZONE1/ZONE2
	Group III	Dust Group IIIC ZONE21/ZONE 22
Equipment Marking	Ex II 2GD Ex db IIC Gb Ex eb IIC Gb Ex tb IIIC Db	
Marking Example *	BMD EBM.. CE 0722  II 2GD Ex db IIC Gb Ex eb IIC Gb Ex tb IIIC Db Ta -40°C to +80°C IP66/68 IMQ 13 ATEX 018X IECEx IMQ 13.0006X	
Thread Type	<ul style="list-style-type: none"> • Metric (M) ISO Pitch 1,5 • NPT (N) ANSI ASME B1.20.1 • Other thread types also available upon request. 	
Cable Type	Non Armoured	
Accessories	<ul style="list-style-type: none"> • Lock nuts • Gaskets (Washers) • Serrated Washers • Earth tags 	
Remarks	<ul style="list-style-type: none"> • Accessories must be ordered separately. • O-ring only available when male thread is Metric. 	
Approvals	Certificate Number	Standards
	IMQ 13 ATEX 018X	EN 60079-0:2012+A11:2013 EN 60079-7:2015 EN 60079-31:2014 EN 60079-1:2014
	IECEx IMQ 13.0006X	IEC 60079-0:2011 Edition:6 IEC 60079-7:2015 Edition:5 IEC 60079-31:2013 Edition:2 IEC 60079-1:2014 Edition:7
	№ TC RU C-TR.AA87.B.00941	ГОСТ 31610.0-2014 ГОСТ IEC 60079-1:2013 ГОСТ IEC 60079-31:2013
	DNV 12.0052 X	ABNT NBR IEC 60079-0:2013 ABNT NBR IEC 60079-1:2009 ABNT NBR IEC 60079-7:2008 ABNT NBR IEC 60079-31:2011
	E-14044	IEC/EN60079-0 IEC/EN60079-7 IEC/EN60079-31 IEC/EN60079-1 IEC/EN 62444

-For more information see our webpage.
* The standard marking consists ATEX & IECEx only. Marking acc. to other standards on request.



Order Coding								
Part Number	Material	Seal	-	Gasket (Washer)	Serrated Washer	Lock Nut	Earth Tag	for Ex e
Mandatory	Mandatory	Mandatory	-	Option	Option	Option	Option	Option
See table	B Brass BN Brass Nickel plated X Stainless steel 316L A Aluminium	C Chloroprene S Silicone	-	WC Chloroprene WS Silicone WF Fiber	WSR Serrated washer	L Lock nut	E Earth tag	TL9
Example								
EBMOSMOSN	BN	S	-	WC	WSR	L	E	TL9

E-CARINA

Rigid Conduit Fittings for Ex d/e applications

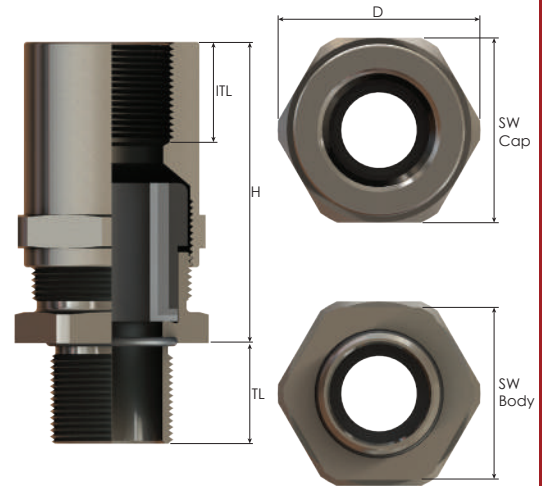

Thread Type **METRIC** acc. to ISO 965-3







Outer Thread Size (Male)	Inner Thread Size (Female)	Clamping Range		Outer Thread Length		Inner Thread Length	Spanner Width		Outer Ø	max. Height	Part Number
		Ø min-max mm	Seal Type	Ex-e min.	Ex-d/e min.		Cap	Body			
				TL m	ITL mm	SW Cap mm	SW Body mm	D mm	H mm		
M12x1,5	NPT 1/4"	4,0 - 8,0	Triple	9,0	16,0	24	22	26,5	49,5	EBM0SM0SN*	
	NPT 3/8"	4,0 - 8,0	Triple	9,0	16,0	24	22	26,5	49,5	EBM0SM01N*	
M16x1,5	NPT 1/4"	4,0 - 8,0	Triple	9,0	16,0	24	22	26,5	49,5	EBM01M0SN	
	NPT 3/8"	4,0 - 12,0	Triple	9,0	16,0	24	22	26,5	49,5	EBM01M01N	
	NPT 1/2"	4,0 - 12,0	Triple	9,0	16,0	24	22	26,5	49,5	EBM01M12N	
M20x1,5	NPT 3/8"	4,0 - 12,0	Triple	9,0	16,0	24	22	26,5	46,0	EBM12M01N	
	NPT 1/2"	4,0 - 12,0	Triple	9,0	16,0	24	22	26,5	46,0	EBM1M1N	
	NPT 1/2"	10,0 - 16,0	Triple	9,0	16,0	30	28	33,0	49,0	EBM12M12N	
	NPT 3/4"	10,0 - 16,0	Triple	9,0	16,0	30	28	33,0	49,0	EBM12M23N	
M25x1,5	NPT 1/2"	10,0 - 16,0	Triple	9,0	16,0	30	28	33,0	49,5	EBM23M12N	
	NPT 3/4"	10,0 - 18,0	Triple	9,0	16,0	30	28	33,0	49,5	EBM2M2N	
	NPT 3/4"	14,0 - 20,0	Triple	9,0	16,0	35	35	39,0	54,0	EBM23M23N	
	NPT 1"	14,0 - 20,0	Triple	9,0	16,0	35	35	39,0	57,0	EBM23M34N	
M32x1,5	NPT 3/4"	14,0 - 20,0	Triple	9,0	16,0	35	35	39,0	52,0	EBM34M23N	
	NPT 1"	14,0 - 24,0	Triple	9,0	16,0	35	35	39,0	56,0	EBM3M3N	
	NPT 1"	22,0 - 26,0	Triple	9,0	16,0	45	45	50,0	67,5	EBM34M34N	
	NPT 1 1/4"	22,0 - 28,0	Triple	9,0	16,0	50	45	55,5	65,5	EBM34M45N	
M40x1,5	NPT 1"	22,0 - 26,0	Triple	9,0	18,0	45	45	50,0	67,5	EBM45M34N	
	NPT 1 1/4"	22,0 - 32,0	Triple	9,0	18,0	50	45	55,0	65,5	EBM4M4N	
	NPT 1 1/4"	26,0 - 34,0	Triple	9,0	18,0	50	50	56,0	68,0	EBM45M45N	
	NPT 1 1/2"	26,0 - 34,0	Triple	9,0	18,0	50	50	56,0	69,0	EBM45M56N	
M50x1,5	NPT 1 1/4"	26,0 - 34,0	Triple	9,0	18,0	50	55	61,0	68,0	EBM5M45N	
	NPT 1 1/2"	26,0 - 35,0	Triple	9,0	18,0	55	55	61,0	69,0	EBM5M5N	
	NPT 1 1/2"	35,0 - 41,0	Triple	9,0	18,0	64	64	70,0	66,5	EBM56M56N	
	NPT 2"	35,0 - 44,0	Triple	9,0	18,0	68	64	75,0	69,5	EBM56M67N	
M63x1,5	NPT 1 1/2"	35,0 - 41,0	Triple	9,0	18,0	64	68	75,0	69,0	EBM67M56N	
	NPT 2"	35,0 - 45,0	Triple	9,0	18,0	68	68	75,0	69,0	EBM6M6N	
	NPT 2"	46,0 - 52,0	Triple	9,0	18,0	80	75	89,0	72,0	EBM67M67N	
	NPT 2 1/2"	46,0 - 56,0	Triple	9,0	18,0	80	75	89,0	76,0	EBM67M78N	
M75x1,5	NPT 2 1/2"	46,0 - 62,0	Triple	9,0	20,0	80	80	89,0	73,0	EBM7M7N	
	NPT 2 1/2"	60,0 - 64,0	Triple	9,0	20,0	95	95	105,0	76,0	EBM78M78N	
	NPT 3"	60,0 - 69,0	Triple	9,0	20,0	95	95	105,0	76,0	EBM78M810N	
M90x1,5	NPT 2 1/2"	60,0 - 64,0	Triple	9,0	20,0	105	95	117,0	76,0	EBM810M78N	
	NPT 3"	60,0 - 75,0	Triple	9,0	20,0	95	95	105,0	76,0	EBM8M8N	
	NPT 3"	75,0 - 79,5	Triple	9,0	20,0	105	105	117,0	76,0	EBM810M810N	
	NPT 4"	75,0 - 82,0	Triple	9,0	20,0	105	105	117,0	76,0	EBM810M10N	
M100x1,5	NPT 3"	75,0 - 79,5	Triple	9,0	20,0	105	105	117,0	76,0	EBM10M810N	
	NPT 4"	75,0 - 85,0	Triple	9,0	20,0	105	105	117,0	76,0	EBM10M10N	
M110x1,5	NPT 4"	85,0 - 95,0	Triple	9,0	20,0	115	115	128,0	77,0	EBM11M11N	

* Only Ex e/ Ex tb execution.

Rigid Conduit Fittings for Ex d/e applications

E-CARINA



Technical Details	
Material	Body Brass, Brass Nickel Plated, Stainless Steel 316L, Aluminium Seal CR (Chloroprene), Silicone O-ring CR (Chloroprene), Silicone
Ingress Protection Rating	IP 68 - 5 Bar, 30 min IP 66
Operating Temperature	Seal Material CR (Chloroprene) -40°C to +80°C Silicone -60°C to +80°C
Equipment For	Gas & Dust potentially explosive atmospheres
Suitable for use in	Group II Gas Group IIC ZONE1/ZONE2 Group III Dust Group IIIC ZONE21/ZONE 22
Equipment Marking	Ex II 2GD Ex db IIC Gb Ex eb IIC Gb Ex tb IIIC Db
Marking Example *	BMD EBM.. CE 0722  II 2GD Ex db IIC Gb Ex eb IIC Gb Ex tb IIIC Db Ta -40°C to +80°C IP66/68 IMQ 13 ATEX 018X IECEx IMQ 13.0006X
Thread Type	<ul style="list-style-type: none"> • Metric (M) ISO Pitch 1,5 • NPT (N) ANSI ASME B1.20.1 • Other thread types also available upon request.
Cable Type	Non Armoured
Accessories	<ul style="list-style-type: none"> • Lock nuts • Gaskets (Washers) • Serrated Washers • Earth tags
Remarks	<ul style="list-style-type: none"> • Accessories must be ordered separately. • O-ring only available when male thread is Metric.
Approvals	Certificate Number Standards
	IMQ 13 ATEX 018X EN 60079-0:2012+A11:2013 EN 60079-7:2015 EN 60079-31:2014 EN 60079-1:2014
	IECEx IMQ 13.0006X IEC 60079-0:2011 Edition:6 IEC 60079-7:2015 Edition:5 IEC 60079-31:2013 Edition:2 IEC 60079-1:2014 Edition:7
	№ TC RU C-TR.AA87.B.00941 ГОСТ 31610.0-2014 ГОСТ IEC 60079-1:2013 ГОСТ IEC 60079-31:2013
	DNV 12.0052 X ABNT NBR IEC 60079-0:2013 ABNT NBR IEC 60079-1:2009 ABNT NBR IEC 60079-7:2008 ABNT NBR IEC 60079-31:2011
	E-14044 IEC/EN60079-0 IEC/EN60079-7 IEC/EN60079-31 IEC/EN60079-1 IEC/EN 62444

-For more information see our webpage.

* The standard marking consists ATEX & IECEx only. Marking acc. to other standards on request.



Order Coding								
Part Number	Material	Seal	-	Gasket (Washer)	Serrated Washer	Lock Nut	Earth Tag	for Ex e
Mandatory	Mandatory	Mandatory	-	Option	Option	Option	Option	Option
See table	B Brass BN Brass Nickel plated X Stainless steel 316L A Aluminium	C Chloroprene S Silicone	-	WC Chloroprene WS Silicone WF Fiber	WSR Serrated washer	L Lock nut	E Earth tag	TL9
Example								
EBMOSMOSN	BN	S	-	WC	WSR	L	E	TL9

E-CARINA

Rigid Conduit Fittings for Ex d/e applications

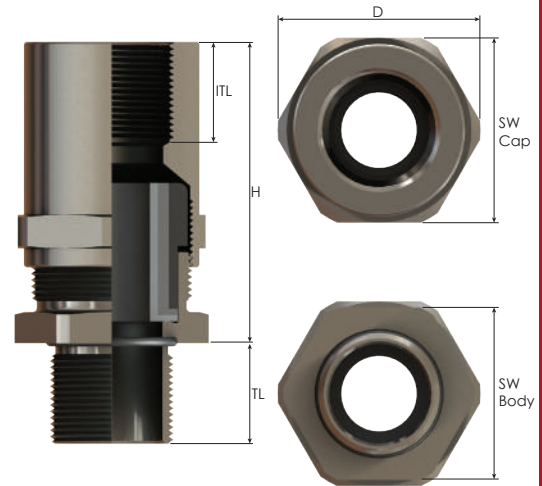

Thread Type **NPT** acc. to ANSI ASME B1.20.1

Outer Thread Size (Male)	Inner Thread Size (Female)	Clamping Range		Outer Thread Length	Inner Thread Length	Spanner Width		Outer Ø	max. Height	Part Number
		Ø min-max mm	Seal Type			SW Cap mm	SW Body mm			
NPT 1/4"	NPT 1/4"	4,0 - 8,0	Triple	16,0	16,0	24	22	26,5	49,5	EBM0S0N0SN*
	NPT 3/8"	4,0 - 8,0	Triple	16,0	16,0	24	22	26,5	49,5	EBM0S0N01N*
NPT 3/8"	NPT 1/4"	4,0 - 8,0	Triple	16,0	16,0	24	22	26,5	49,5	EBM01N0SN
	NPT 3/8"	4,0 - 12,0	Triple	16,0	16,0	24	22	26,5	49,5	EBM01N01N
	NPT 1/2"	4,0 - 12,0	Triple	16,0	16,0	24	22	26,5	49,5	EBM01N12N
NPT 1/2"	NPT 3/8"	4,0 - 12,0	Triple	16,0	16,0	24	22	26,5	46,0	EBM12N01N
	NPT 1/2"K	4,0 - 12,0	Triple	16,0	16,0	24	22	26,5	46,0	EBM1N1N
	NPT 1/2"	10,0 - 16,0	Triple	16,0	16,0	30	28	33,0	49,0	EBM12N12N
	NPT 3/4"	10,0 - 16,0	Triple	16,0	16,0	30	28	33,0	49,0	EBM12N23N
NPT 3/4"	NPT 1/2"	10,0 - 16,0	Triple	16,0	16,0	30	28	33,0	49,0	EBM23N12N
	NPT 3/4"K	10,0 - 18,0	Triple	16,0	16,0	30	28	33,0	49,0	EBM2N2N
	NPT 3/4"	14,0 - 20,0	Triple	16,0	16,0	35	35	39,0	53,0	EBM23N23N
	NPT 1"	14,0 - 20,0	Triple	16,0	20,0	35	35	39,0	57,0	EBM23N34N
NPT 1"	NPT 3/4"	14,0 - 20,0	Triple	20,0	16,0	35	35	39,0	52,0	EBM34N23N
	NPT 1"K	14,0 - 24,0	Triple	20,0	20,0	35	35	39,0	56,0	EBM3N3N
	NPT 1"	22,0 - 26,0	Triple	20,0	20,0	45	45	50,0	67,0	EBM34N34N
	NPT 1 1/4"	22,0 - 26,0	Triple	20,0	20,0	50	45	55,5	65,5	EBM34N45N
NPT 1 1/4"	NPT 1"	22,0 - 26,0	Triple	20,0	20,0	45	45	50,0	67,5	EBM45N34N
	NPT 1 1/4"K	22,0 - 32,0	Triple	20,0	20,0	50	45	55,5	65,5	EBM4N4N
	NPT 1 1/4"	26,0 - 34,0	Triple	20,0	20,0	50	50	55,5	68,0	EBM45N45N
	NPT 1 1/2"	26,0 - 34,0	Triple	20,0	20,0	50	50	55,5	69,0	EBM45N56N
NPT 1 1/2"	NPT 1 1/4"	26,0 - 34,0	Triple	20,0	20,0	50	55	61,0	68,0	EBM5N45N
	NPT 1 1/2"K	26,0 - 35,0	Triple	20,0	20,0	55	55	61,0	69,0	EBM5N5N
	NPT 1 1/2"	35,0 - 41,0	Triple	20,0	20,0	64	64	70,0	66,0	EBM56N56N
	NPT 2"	35,0 - 41,0	Triple	20,0	20,0	68	64	75,0	69,5	EBM56N67N
NPT 2"	NPT 1 1/2"	35,0 - 41,0	Triple	20,0	20,0	64	68	75,0	69,5	EBM67N56N
	NPT 2"K	35,0 - 45,0	Triple	20,0	20,0	68	68	75,0	69,5	EBM6N6N
	NPT 2"	46,0 - 52,0	Triple	20,0	20,0	80	75	89,0	72,0	EBM67N67N
	NPT 2 1/2"	46,0 - 52,0	Triple	20,0	21,0	80	75	89,0	76,0	EBM67N78N
NPT 2 1/2"	NPT 2"	46,0 - 52,0	Triple	21,0	20,0	95	80	105,0	72,0	EBM78N67N
	NPT 2 1/2"K	46,0 - 62,0	Triple	21,0	21,0	80	80	89,0	73,0	EBM7N7N
	NPT 2 1/2"	60,0 - 64,0	Triple	21,0	21,0	95	95	105,0	76,0	EBM78N78N
	NPT 3"	60,0 - 64,0	Triple	21,0	21,0	95	95	105,0	76,0	EBM78N810N
NPT 3"	NPT 2 1/2"	60,0 - 64,0	Triple	21,0	21,0	105	95	117,0	76,0	EBM810N78N
	NPT 3"K	60,0 - 75,0	Triple	21,0	21,0	95	95	105,0	76,0	EBM8N8N
	NPT 3"	75,0 - 79,5	Triple	21,0	21,0	105	105	117,0	76,0	EBM810N810N
	NPT 4"K	75,0 - 79,5	Triple	21,0	21,0	105	105	117,0	76,0	EBM810N10N
NPT 4"	NPT 3"	75,0 - 79,5	Triple	21,0	21,0	115	115	128,0	76,0	EBM11N810N
	NPT 4"K	75,0 - 85,0	Triple	21,0	21,0	105	115	128,0	76,0	EBM10N10N
	NPT 4"	85,0 - 95,0	Triple	21,0	21,0	115	115	128,0	77,0	EBM11N11N

* Only Ex e/ Ex tb execution.

Rigid Conduit Fittings for Ex d/e Applications

E-CARINA FLAT



Technical Details		
Material	Body	Brass, Brass Nickel Plated, Stainless Steel 316L, Aluminium
	Seal	CR (Chloroprene), Silicone
	O-ring	CR (Chloroprene), Silicone
Ingress Protection Rating		IP 68 - 5 Bar, 30 min IP 66
Operating Temperature	Seal Material	
	CR (Chloroprene)	Silicone
	Ex d/tb Ex e/tb	-40°C to +80°C -40°C to +80°C -40°C to +80°C -60°C to +140°C
Equipment For		Gas & Dust potentially explosive atmospheres
Suitable for use in	Group II	Gas Group IIC ZONE1/ZONE2
	Group III	Dust Group IIIC ZONE21/ZONE 22
Equipment Marking		Ex II 2GD Ex d IIC Gb Ex e IIC Gb Ex tb IIIC Db
Marking Example *		BMD EBM.. CE 0722 II 2GD Ex d IIC Gb Ex e IIC Gb Ex tb IIIC Db Ta-40°C to +80°C IP66/68 IMQ 13 ATEX 018X IECEx IMQ 13.0006X
Thread Type		<ul style="list-style-type: none"> • Metric (M) ISO Pitch 1,5 • NPT (N) ANSI ASME B1.20.1 • Other thread types also available upon request.
Cable Type		Flat form non armoured cable
Accessories		<ul style="list-style-type: none"> • Lock nuts • Gaskets (Washers) • Serrated Washers • Earth tags • Flat cable Seals
Remarks		<ul style="list-style-type: none"> • Accessories must be ordered separately. • O-ring only available when male thread is Metric.
Approvals		Certificate Number Standards
	IMQ 13 ATEX 018X	EN 60079-0:2012+A11:2013 EN 60079-7:2015 EN 60079-31:2014 EN 60079-1:2014
	IECEx IMQ 13.0006X	IEC 60079-0:2011 Edition:6 IEC 60079-7:2015 Edition:5 IEC 60079-31:2013 Edition:2 IEC 60079-1:2014 Edition:7
	№ TC RU C-TR.AA87.B.00941	ГОСТ 31610.0-2014 ГОСТ IEC 60079-1:2013 ГОСТ IEC 60079-31:2013
	DNV 12.0052 X	ABNT NBR IEC 60079-0:2013 ABNT NBR IEC 60079-1:2009 ABNT NBR IEC 60079-7:2008 ABNT NBR IEC 60079-31:2011
	E-14044	IEC/EN60079-0 IEC/EN60079-7 IEC/EN60079-31 IEC/EN60079-1 IEC/EN 62444

-For more information see our webpage.

* The standard marking consists ATEX & IECEx only. Marking acc. to other standards on request.



Order Coding								
Part Number	Material	Seal	-	Gasket (Washer)	Serrated Washer	Lock Nut	Earth Tag	for Ex e
Mandatory	Mandatory	Mandatory	-	Option	Option	Option	Option	Option
See table	B Brass BN Brass Nickel plated X Stainless steel 316L A Aluminium	C Chloroprene S Silicone	-	WC Chloroprene WS Silicone WF Fiber	WSR Serrated washer	L Lock nut	E Earth tag	TL9
Example								
EBM1M1M(FxA1)	BN	S	-	WC	WSR	L	E	TL9

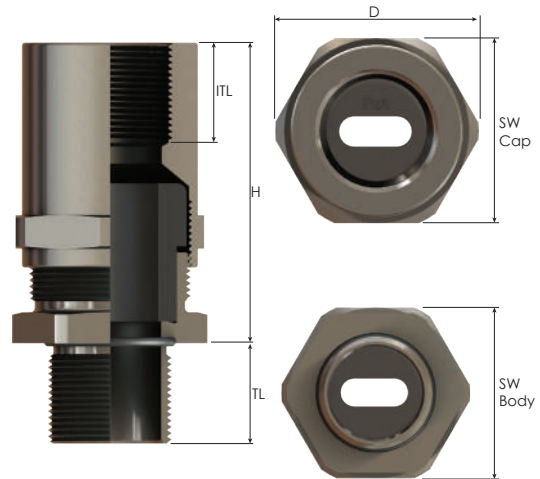
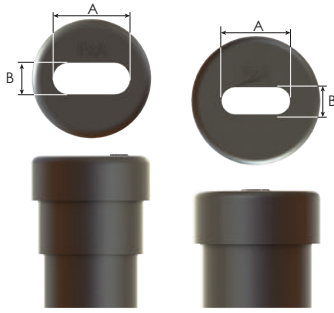

E-CARINA FLAT

Rigid Conduit Fittings for Ex d/e Applications

Thread Type **METRIC** acc. to ISO 965-3

Outer Thread Size (Male)	Inner Thread Size (Female)	Flat Hole		Outer Thread Length		Inner Thread Length	Spanner Width		Outer Ø	max.Height	Part Number
		Height	Width	Ex-e min.	Ex-d/e min.		Cap	Body			
		B mm	A mm			ITL mm	SW Cap mm	SW Body mm	D mm	H mm	
M20x1,5	M20x1,5	5,0	12,2	9,0	16,0	16,0	24	22	26,5	47,0	EBM1M1M(FxA1)
		5,5	11,7	9,0	16,0	16,0	24	22	26,5	47,0	EBM1M1M(FxC1)
		6,0	8,5	9,0	16,0	16,0	24	22	26,5	47,0	EBM1M1M(FxB1)
		6,0	12,2	9,0	16,0	16,0	24	22	26,5	47,0	EBM1M1M(FxD1)
		6,3	10,8	9,0	16,0	16,0	24	22	26,5	47,0	EBM1M1M(FxE1)
		6,7	12,7	9,0	16,0	16,0	24	22	26,5	47,0	EBM1M1M(FxG1)
M20x1,5	M20x1,5	5,0	12,8	9,0	16,0	16,0	30	28	33,0	49,5	EBM12M12M(FxA2)
		5,5	10,7	9,0	16,0	16,0	30	28	33,0	49,5	EBM12M12M(FxH2)
		5,5	11,7	9,0	16,0	16,0	30	28	33,0	49,5	EBM12M12M(FxC2)
		6,0	8,5	9,0	16,0	16,0	30	28	33,0	49,5	EBM12M12M(FxB2)
		6,0	14,0	9,0	16,0	16,0	30	28	33,0	49,5	EBM12M12M(FxD2)
		6,8	15,3	9,0	16,0	16,0	30	28	33,0	49,5	EBM12M12M(FxG2)
		7,3	13,3	9,0	16,0	16,0	30	28	33,0	49,5	EBM12M12M(FxF2)
		9,1	12,3	9,0	16,0	16,0	30	28	33,0	49,5	EBM12M12M(FxE2)
M20x1,5	M25x1,5	5,0	12,8	9,0	16,0	16,0	30	28	33,0	49,5	EBM12M23M(FxA2)
		5,5	10,7	9,0	16,0	16,0	30	28	33,0	49,5	EBM12M23M(FxH2)
		5,5	11,7	9,0	16,0	16,0	30	28	33,0	49,5	EBM12M23M(FxC2)
		6,0	8,5	9,0	16,0	16,0	30	28	33,0	49,5	EBM12M23M(FxB2)
		6,0	14,0	9,0	16,0	16,0	30	28	33,0	49,5	EBM12M23M(FxD2)
		6,8	15,3	9,0	16,0	16,0	30	28	33,0	49,5	EBM12M23M(FxG2)
		7,3	13,3	9,0	16,0	16,0	30	28	33,0	49,5	EBM12M23M(FxF2)
		9,1	12,3	9,0	16,0	16,0	30	28	33,0	49,5	EBM12M23M(FxE2)
M25x1,5	M20x1,5	5,0	12,8	9,0	16,0	16,0	30	28	33,0	50,0	EBM23M12M(FxA2)
		5,5	10,7	9,0	16,0	16,0	30	28	33,0	50,0	EBM23M12M(FxH2)
		5,5	11,7	9,0	16,0	16,0	30	28	33,0	50,0	EBM23M12M(FxC2)
		6,0	8,5	9,0	16,0	16,0	30	28	33,0	50,0	EBM23M12M(FxB2)
		6,0	14,0	9,0	16,0	16,0	30	28	33,0	50,0	EBM23M12M(FxD2)
		6,8	15,3	9,0	16,0	16,0	30	28	33,0	50,0	EBM23M12M(FxG2)
		7,3	13,3	9,0	16,0	16,0	30	28	33,0	50,0	EBM23M12M(FxF2)
		9,1	12,3	9,0	16,0	16,0	30	28	33,0	50,0	EBM23M12M(FxE2)
M25x1,5	M25x1,5	5,0	12,8	9,0	16,0	16,0	30	28	33,0	50,0	EBM2M2M(FxA2)
		5,5	10,7	9,0	16,0	16,0	30	28	33,0	50,0	EBM2M2M(FxH2)
		5,5	11,7	9,0	16,0	16,0	30	28	33,0	50,0	EBM2M2M(FxC2)
		6,0	8,5	9,0	16,0	16,0	30	28	33,0	50,0	EBM2M2M(FxB2)
		6,0	14,0	9,0	16,0	16,0	30	28	33,0	50,0	EBM2M2M(FxD2)
		6,8	15,3	9,0	16,0	16,0	30	28	33,0	50,0	EBM2M2M(FxG2)
		7,3	13,3	9,0	16,0	16,0	30	28	33,0	50,0	EBM2M2M(FxF2)
		9,1	12,3	9,0	16,0	16,0	30	28	33,0	50,0	EBM2M2M(FxE2)

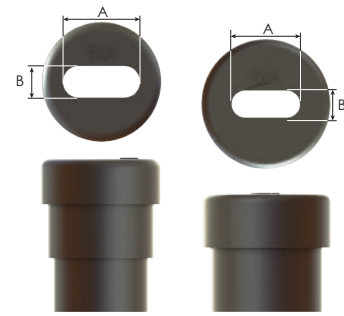
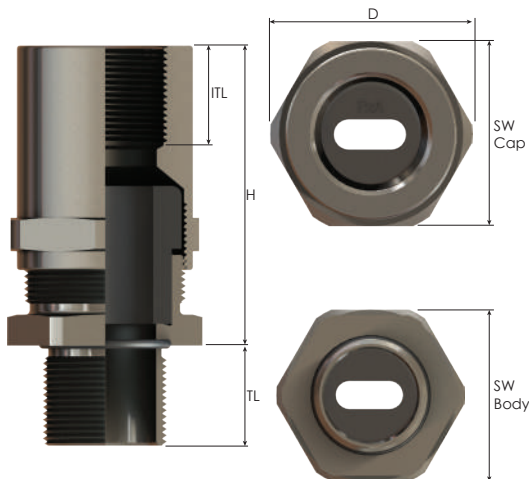

E-CARINA FLAT Rigid Conduit Fittings for Ex d/e Applications

Thread Type **NPT** acc. to ANSI ASME B1.20.1

Outer Thread Size (Male)	Inner Thread Size (Female)	Flat Hole		Outer Thread Length	Inner Thread Length	Spanner Width		Outer Ø	max.Height	Part Number
		Height	Width			Cap	Body			
		B mm	A mm	TL mm	ITL mm	SW Cap mm	SW Body mm	D mm	H mm	
NPT 1/2"	NPT 1/2"	5,0	12,2	16,0	16,0	24	22	26,5	47,5	EBM1N1N(FxA1)
		5,5	11,7	16,0	16,0	24	22	26,5	47,5	EBM1N1N(FxC1)
		6,0	8,5	16,0	16,0	24	22	26,5	47,5	EBM1N1N(FxB1)
		6,0	12,2	16,0	16,0	24	22	26,5	47,5	EBM1N1N(FxD1)
		6,3	10,8	16,0	16,0	24	22	26,5	47,5	EBM1N1N(FxE1)
		6,7	12,7	16,0	16,0	24	22	26,5	47,5	EBM1N1N(FxG1)
		5,0	12,8	16,0	16,0	30	28	33,0	49,0	EBM12N12N(FxA2)
		5,5	10,7	16,0	16,0	30	28	33,0	49,0	EBM12N12N(FxH2)
		5,5	11,7	16,0	16,0	30	28	33,0	49,0	EBM12N12N(FxC2)
		6,0	8,5	16,0	16,0	30	28	33,0	49,0	EBM12N12N(FxB2)
		6,0	14,0	16,0	16,0	30	28	33,0	49,0	EBM12N12N(FxD2)
		6,8	15,3	16,0	16,0	30	28	33,0	49,0	EBM12N12N(FxG2)
		7,3	13,3	16,0	16,0	30	28	33,0	49,0	EBM12N12N(FxF2)
		9,1	12,3	16,0	16,0	30	28	33,0	49,0	EBM12N12N(FxE2)
NPT 1/2"	NPT 3/4"	5,0	12,8	16,0	16,0	30	28	33,0	49,0	EBM12N23N(FxA2)
		5,5	10,7	16,0	16,0	30	28	33,0	49,0	EBM12N23N(FxH2)
		5,5	11,7	16,0	16,0	30	28	33,0	49,0	EBM12N23N(FxC2)
		6,0	8,5	16,0	16,0	30	28	33,0	49,0	EBM12N23N(FxB2)
		6,0	14,0	16,0	16,0	30	28	33,0	49,0	EBM12N23N(FxD2)
		6,8	15,3	16,0	16,0	30	28	33,0	49,0	EBM12N23N(FxG2)
		7,3	13,3	16,0	16,0	30	28	33,0	49,0	EBM12N23N(FxF2)
		9,1	12,3	16,0	16,0	30	28	33,0	49,0	EBM12N23N(FxE2)
NPT 3/4"	NPT 1/2"	5,0	12,8	16,0	16,0	30	28	33,0	49,0	EBM23N12N(FxA2)
		5,5	10,7	16,0	16,0	30	28	33,0	49,0	EBM23N12N(FxH2)
		5,5	11,7	16,0	16,0	30	28	33,0	49,0	EBM23N12N(FxC2)
		6,0	8,5	16,0	16,0	30	28	33,0	49,0	EBM23N12N(FxB2)
		6,0	14,0	16,0	16,0	30	28	33,0	49,0	EBM23N12N(FxD2)
		6,8	15,3	16,0	16,0	30	28	33,0	49,0	EBM23N12N(FxG2)
		7,3	13,3	16,0	16,0	30	28	33,0	49,0	EBM23N12N(FxF2)
		9,1	12,3	16,0	16,0	30	28	33,0	49,0	EBM23N12N(FxE2)
NPT 3/4"	NPT 3/4"	5,0	12,8	16,0	16,0	30	28	33,0	49,0	EBM2N2N(FxA2)
		5,5	10,7	16,0	16,0	30	28	33,0	49,0	EBM2N2N(FxH2)
		5,5	11,7	16,0	16,0	30	28	33,0	49,0	EBM2N2N(FxC2)
		6,0	8,5	16,0	16,0	30	28	33,0	49,0	EBM2N2N(FxB2)
		6,0	14,0	16,0	16,0	30	28	33,0	49,0	EBM2N2N(FxD2)
		6,8	15,3	16,0	16,0	30	28	33,0	49,0	EBM2N2N(FxG2)
		7,3	13,3	16,0	16,0	30	28	33,0	49,0	EBM2N2N(FxF2)
		9,1	12,3	16,0	16,0	30	28	33,0	49,0	EBM2N2N(FxE2)

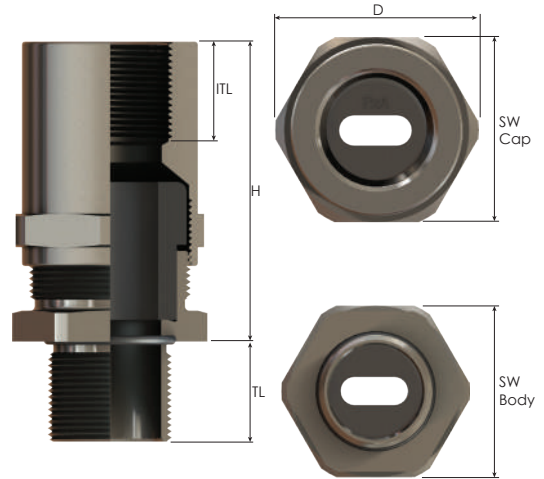
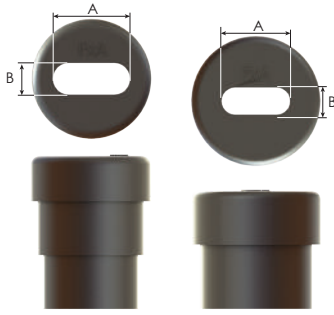

E-CARINA FLAT

Rigid Conduit Fittings for Ex d/e applications

Thread Type METRIC acc. to ISO 965-3 > NPT acc. to ANSI ASME B1.20.1											
Outer Thread Size (Male)	Inner Thread Size (Female)	Flat Hole		Outer Thread Length		Inner Thread Length	Spanner Width		Outer Ø	max.Height	Part Number
		Height	Width	Ex-e min.	Ex-d/e min.		Cap	Body			
		B mm	A mm	TL mm		ITL mm	SW Cap mm	SW Body mm	D mm	H mm	
M20X1,5	NPT 1/2"	5,0	12,2	9,0	16,0	16,0	24	22	26,5	46,5	EBM1M1N(FxA1)
		5,5	11,7	9,0	16,0	16,0	24	22	26,5	46,5	EBM1M1N(FxC1)
		6,0	8,5	9,0	16,0	16,0	24	22	26,5	46,5	EBM1M1N(FxB1)
		6,0	12,2	9,0	16,0	16,0	24	22	26,5	46,5	EBM1M1N(FxD1)
		6,3	10,8	9,0	16,0	16,0	24	22	26,5	46,5	EBM1M1N(FxE1)
		6,7	12,7	9,0	16,0	16,0	24	22	26,5	46,5	EBM1M1N(FxG1)
		5,0	12,8	9,0	16,0	16,0	30	28	33,0	49,0	EBM12M12N(FxA2)
		5,5	10,7	9,0	16,0	16,0	30	28	33,0	49,0	EBM12M12N(FxH2)
		5,5	11,7	9,0	16,0	16,0	30	28	33,0	49,0	EBM12M12N(FxC2)
		6,0	8,5	9,0	16,0	16,0	30	28	33,0	49,0	EBM12M12N(FxB2)
		6,0	14,0	9,0	16,0	16,0	30	28	33,0	49,0	EBM12M12N(FxD2)
		6,8	15,3	9,0	16,0	16,0	30	28	33,0	49,0	EBM12M12N(FxG2)
		7,3	13,3	9,0	16,0	16,0	30	28	33,0	49,0	EBM12M12N(FxF2)
		9,1	12,3	9,0	16,0	16,0	30	28	33,0	49,0	EBM12M12N(FxE2)
M20X1,5	NPT 3/4"	5,0	12,8	9,0	16,0	16,0	30	28	33,0	49,0	EBM12M23N(FxA2)
		5,5	10,7	9,0	16,0	16,0	30	28	33,0	49,0	EBM12M23N(FxH2)
		5,5	11,7	9,0	16,0	16,0	30	28	33,0	49,0	EBM12M23N(FxC2)
		6,0	8,5	9,0	16,0	16,0	30	28	33,0	49,0	EBM12M23N(FxB2)
		6,0	14,0	9,0	16,0	16,0	30	28	33,0	49,0	EBM12M23N(FxD2)
		6,8	15,3	9,0	16,0	16,0	30	28	33,0	49,0	EBM12M23N(FxG2)
		7,3	13,3	9,0	16,0	16,0	30	28	33,0	49,0	EBM12M23N(FxF2)
		9,1	12,3	9,0	16,0	16,0	30	28	33,0	49,0	EBM12M23N(FxE2)
M25X1,5	NPT 1/2"	5,0	12,8	9,0	16,0	16,0	30	28	33,0	49,5	EBM23M12N(FxA2)
		5,5	10,7	9,0	16,0	16,0	30	28	33,0	49,5	EBM23M12N(FxH2)
		5,5	11,7	9,0	16,0	16,0	30	28	33,0	49,5	EBM23M12N(FxC2)
		6,0	8,5	9,0	16,0	16,0	30	28	33,0	49,5	EBM23M12N(FxB2)
		6,0	14,0	9,0	16,0	16,0	30	28	33,0	49,5	EBM23M12N(FxD2)
		6,8	15,3	9,0	16,0	16,0	30	28	33,0	49,5	EBM23M12N(FxG2)
		7,3	13,3	9,0	16,0	16,0	30	28	33,0	49,5	EBM23M12N(FxF2)
		9,1	12,3	9,0	16,0	16,0	30	28	33,0	49,5	EBM23M12N(FxE2)
M25X1,5	NPT 3/4"	5,0	12,8	9,0	16,0	16,0	30	28	33,0	49,5	EBM2M2N(FxA2)
		5,5	10,7	9,0	16,0	16,0	30	28	33,0	49,5	EBM2M2N(FxH2)
		5,5	11,7	9,0	16,0	16,0	30	28	33,0	49,5	EBM2M2N(FxC2)
		6,0	8,5	9,0	16,0	16,0	30	28	33,0	49,5	EBM2M2N(FxB2)
		6,0	14,0	9,0	16,0	16,0	30	28	33,0	49,5	EBM2M2N(FxD2)
		6,8	15,3	9,0	16,0	16,0	30	28	33,0	49,5	EBM2M2N(FxG2)
		7,3	13,3	9,0	16,0	16,0	30	28	33,0	49,5	EBM2M2N(FxF2)
		9,1	12,3	9,0	16,0	16,0	30	28	33,0	49,5	EBM2M2N(FxE2)

Rigid Conduit Fittings for Ex d/e applications

E-CYGNUS



Technical Details		
Material	Body	Brass, Brass Nickel Plated, Stainless Steel 316L, Aluminium
	Inner Parts	Stainless Steel 316L
	Seal	CR (Chloroprene), Silicone
	O-ring	CR (Chloroprene), Silicone
Ingress Protection Rating	IP 68 - 5 Bar, 30 min IP 66	
Operating Temperature	Seal Material	
	CR (Chloroprene)	Silicone
	Ex d/tb	-40°C to +80°C
	Ex e/tb	-40°C to +80°C
Equipment For	Gas & Dust potentially explosive atmospheres	
Suitable for use in	Group II	Gas Group IIC ZONE1/ZONE2
	Group III	Dust Group IIIC ZONE21/ZONE 22
Equipment Marking	Ex II 2GD Ex db IIC Gb Ex eb IIC Gb Ex tb IIIC Db	
Marking Example *	BMD EBMS., CE 0722 II 2GD Ex db IIC Gb Ex eb IIC Gb Ex tb IIIC Db Ta-40°C to +80°C IP66/68 IMQ 13 ATEX 018X IECEx IMQ 13.0006X	
Thread Type	<ul style="list-style-type: none"> • Metric (M) ISO Pitch 1,5 • NPT (N) ANSI ASME B1.20.1 • Other thread types also available upon request. 	
Cable Type	Non Armoured	
Accessories	<ul style="list-style-type: none"> • Lock nuts • Gaskets (Washers) • Serrated Washers • Earth tags 	
Remarks	<ul style="list-style-type: none"> • Accessories must be ordered separately. • O-ring only available when male thread is Metric. 	
Approvals	Certificate Number	Standards
	IMQ 13 ATEX 018X	EN 60079-0:2012+A11:2013 EN 60079-7:2015 EN 60079-31:2014 EN 60079-1:2014
	IECEx IMQ 13.0006X	IEC 60079-0:2011 Edition:6 IEC 60079-7:2015 Edition:5 IEC 60079-31:2013 Edition:2 IEC 60079-1:2014 Edition:7
	№ TC RU C-TR.AA87.B.00941	ГОСТ 31610.0-2014 ГОСТ IEC 60079-1:2013 ГОСТ IEC 60079-31:2013
	DNV 12.0052 X	ABNT NBR IEC 60079-0:2013 ABNT NBR IEC 60079-1:2009 ABNT NBR IEC 60079-7:2008 ABNT NBR IEC 60079-31:2011
	E-14044	IEC/EN60079-0 IEC/EN60079-7 IEC/EN60079-31 IEC/EN60079-1 IEC/EN 62444

-For more information see our webpage.

* The standard marking consists ATEX & IECEx only. Marking acc. to other standards on request.



Order Coding								
Part Number	Material	Seal	-	Gasket (Washer)	Serrated Washer	Lock Nut	Earth Tag	for Ex e
Mandatory	Mandatory	Mandatory	-	Option	Option	Option	Option	Option
See table	B Brass BN Brass Nickel plated X Stainless steel 316L A Aluminium	C Chloroprene S Silicone	-	WC Chloroprene WS Silicone WF Fiber	WSR Serrated washer	L Lock nut	E Earth tag	TL9
Example								
EBMS23M12N	BN	S	-	WC	WSR	L	E	TL9

E-CYGNUS

Rigid Conduit Swivel Fittings for Ex d/e applications

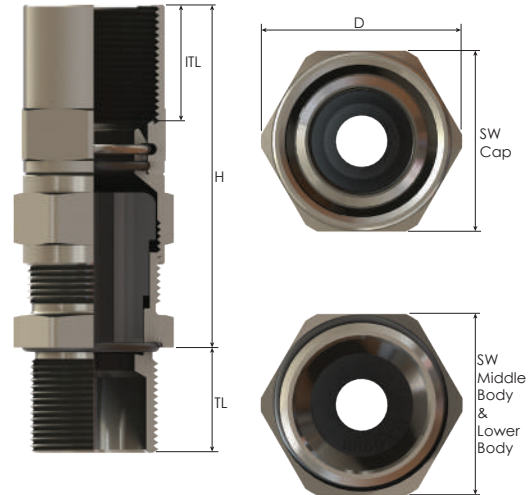







Thread Type **METRIC** acc. to ISO 965-3 > **NPT** acc. to ANSI ASME B1.20.1

Outer Thread Size (Male)	Inner Thread Size (Female)	Clamping Range		Outer Thread Length		Inner Thread Length	Spanner Width			Outer Ø	max. Height	Part Number
				Ex-e min. Ex-d/e min.			Cap	Upper Body	Lower Body			
				TL mm	ITL mm							
M16x1,5	NPT 3/8"	4,0 - 12,0	Triple	9,0	16,0	16,0	27	27	22	30,0	56,5	EBMS01M01N
	NPT 1/2"			9,0	16,0	16,0	27	27	22	30,0	56,0	EBMS01M12N
M20x1,5	NPT 3/8"	4,0 - 12,0	Triple	9,0	16,0	16,0	27	27	22	30,0	52,0	EBMS12M01N
	NPT 1/2"			9,0	16,0	16,0	27	27	22	30,0	52,0	EBMS1M1N
	NPT 3/4"	10,0 - 16,0	Triple	9,0	16,0	16,0	32	32	28	35,5	52,5	EBMS12M12N
	NPT 1"			9,0	16,0	16,0	32	32	28	35,5	56,5	EBMS12M23N
M25x1,5	NPT 1/2"	10,0 - 16,0	Triple	9,0	16,0	16,0	32	32	28	35,5	55,0	EBMS23M12N
	NPT 3/4"			9,0	16,0	16,0	32	32	28	35,5	57,0	EBMS2M2N
	NPT 3/4"	14,0 - 20,0	Triple	9,0	16,0	16,0	40	40	35	44,5	59,5	EBMS23M23N
	NPT 1"			9,0	16,0	20,0	40	40	35	44,5	65,0	EBMS23M34N
M32x1,5	NPT 3/4"	14,0 - 20,0	Triple	9,0	16,0	16,0	40	40	35	44,5	58,5	EBMS34M23N
	NPT 1"			9,0	16,0	20,0	40	40	35	44,5	64,0	EBMS3M3N
	NPT 1"	22,0 - 28,0	Triple	9,0	16,0	20,0	48	45	45	53,3	68,5	EBMS34M34N
	NPT 1 1/4"			9,0	16,0	20,0	48	45	45	53,3	68,5	EBMS34M45N
M40x1,5	NPT 1"	22,0 - 26,0	Triple	9,0	18,0	20,0	48	45	45	53,3	69,0	EBMS45M34N
	NPT 1 1/4"			9,0	18,0	20,0	48	45	45	53,3	69,0	EBMS4M4N
	NPT 1 1/4"	26,0 - 34,0	Triple	9,0	18,0	20,0	55	55	50	61,0	76,0	EBMS45M45N
	NPT 1 1/2"			9,0	18,0	20,0	55	55	50	61,0	76,0	EBMS45M56N
M50x1,5	NPT 1 1/4"	26,0 - 34,0	Triple	9,0	18,0	20,0	55	55	55	61,0	76,0	EBMS56M45N
	NPT 1 1/2"			9,0	18,0	20,0	55	55	55	61,0	76,0	EBMS5M5N
	NPT 1 1/2"	35,0 - 44,0	Triple	9,0	18,0	20,0	64	64	64	70,0	75,5	EBMS56M56N
	NPT 2"			9,0	18,0	20,0	80	80	64	89,0	85,5	EBMS56M67N
M63x1,5	NPT 1 1/2"	35,0 - 41,0	Triple	9,0	18,0	20,0	64	64	68	75,0	75,5	EBMS67M56N
	NPT 2"			9,0	18,0	20,0	64	64	68	75,0	77,0	EBMS6M6N
	NPT 2"	46,0 - 56,0	Triple	9,0	18,0	20,0	80	80	75	89,0	85,5	EBMS67M67N
	NPT 2 1/2"			9,0	18,0	21,0	95	95	75	105,0	90,0	EBMS67M78N
M75x1,5	NPT 2"	46,0 - 52,0	Triple	9,0	20,0	20,0	80	80	80	89,0	85,5	EBMS78M67N
	NPT 2 1/2"			9,0	20,0	21,0	80	80	80	89,0	86,5	EBMS7M7N
	NPT 2 1/2"	60,0 - 69,0	Triple	9,0	20,0	21,0	95	95	95	105,0	90,0	EBMS78M78N
	NPT 3"			9,0	20,0	21,0	105	105	95	117,0	90,0	EBMS78M810N
M90x1,5	NPT 2 1/2"	60,0 - 64,0	Triple	9,0	20,0	21,0	95	95	95	105,0	90,0	EBMS810M78N
	NPT 3"			9,0	20,0	21,0	95	95	95	105,0	90,0	EBMS8M8N
	NPT 3"	75,0 - 82,0	Triple	9,0	20,0	21,0	105	105	105	117,0	90,0	EBMS810M810N
	NPT 4"			9,0	20,0	21,0	115	115	105	128,0	90,0	EBMS810M10N
M100x1,5	NPT 3"	75,0 - 85,0	Triple	9,0	20,0	21,0	105	105	105	117,0	90,0	EBMS10M810N
	NPT 4"			9,0	20,0	21,0	115	115	105	128,0	90,0	EBMS10M10N
M110x1,5	NPT 4"	85,0 - 95,0	Triple	9,0	20,0	21,0	115	115	115	128,0	91,0	EBMS11M11N

Rigid Conduit Fittings for Ex d/e applications

E-CYGNUS



Technical Details		
Material	Body	Brass, Brass Nickel Plated, Stainless Steel 316L, Aluminium
	Inner Parts	Stainless Steel 316L
	Seal	CR (Chloroprene), Silicone
	O-ring	CR (Chloroprene), Silicone
Ingress Protection Rating	IP 68 - 5 Bar, 30 min IP 66	
Operating Temperature	Seal Material	
	CR (Chloroprene)	Silicone
	Ex d/tb	-40°C to +80°C
Ex e/tb	-40°C to +80°C	
Equipment For	Gas & Dust potentially explosive atmospheres	
Suitable for use in	Group II	Gas Group IIC ZONE1/ZONE2
	Group III	Dust Group IIIC ZONE21/ZONE 22
Equipment Marking	Ex II 2GD Ex db IIC Gb Ex eb IIC Gb Ex tb IIIC Db	
Marking Example *	BMD EBMS.. CE 0722  II 2GD Ex db IIC Gb Ex eb IIC Gb Ex tb IIIC Db Ta-40°C to +80°C IP66/68 IMQ 13 ATEX 018X IECEx IMQ 13.0006X	
Thread Type	<ul style="list-style-type: none"> • Metric (M) ISO Pitch 1,5 • NPT (N) ANSI ASME B1.20.1 • Other thread types also available upon request. 	
Cable Type	Non Armoured	
Accessories	<ul style="list-style-type: none"> • Lock nuts • Gaskets (Washers) • Serrated Washers • Earth tags 	
Remarks	<ul style="list-style-type: none"> • Accessories must be ordered separately. • O-ring only available when male thread is Metric. 	
Approvals	Certificate Number	Standards
	IMQ 13 ATEX 018X	EN 60079-0:2012+A11:2013 EN 60079-7:2015 EN 60079-31:2014 EN 60079-1:2014
	IECEX IMQ 13.0006X	IEC 60079-0:2011 Edition:6 IEC 60079-7:2015 Edition:5 IEC 60079-31:2013 Edition:2 IEC 60079-1:2014 Edition:7
	№ TC RU C-TR.AA87.B.00941	ГОСТ 31610.0-2014 ГОСТ IEC 60079-1:2013 ГОСТ IEC 60079-31:2013
	DNV 12.0052 X	ABNT NBR IEC 60079-0:2013 ABNT NBR IEC 60079-1:2009 ABNT NBR IEC 60079-7:2008 ABNT NBR IEC 60079-31:2011
	E-14044	IEC/EN60079-0 IEC/EN60079-7 IEC/EN60079-31 IEC/EN60079-1 IEC/EN 62444

-For more information see our webpage.

* The standard marking consists ATEX & IECEx only. Marking acc. to other standards on request.



Order Coding								
Part Number	Material	Seal	- Gasket (Washer)	Serrated Washer	Lock Nut	Earth Tag	for Ex e	
Mandatory	Mandatory	Mandatory	- Option	Option	Option	Option	Option	Option
See table	B Brass BN Brass Nickel plated X Stainless steel 316L A Aluminium	C Chloroprene S Silicone	- WC Chloroprene WS Silicone WF Fiber	WSR Serrated washer	L Lock nut	E Earth tag	TL9	
Example	EBMS23M12N BN	S	- WC	WSR	L	E	TL9	

E-CYGNUS

Rigid Conduit Swivel Fittings for Ex d/e applications

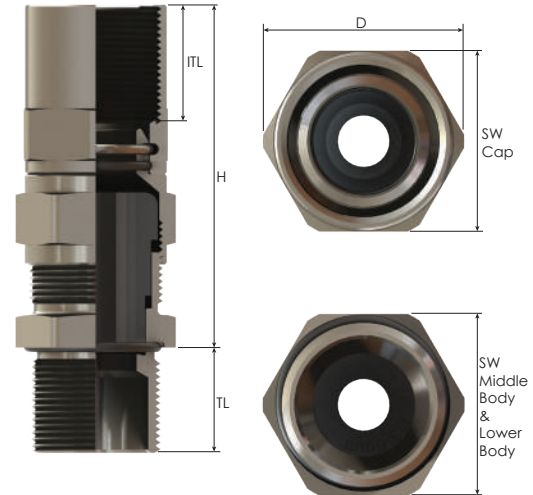

Thread Type NPT acc. to ANSI ASME B1.20.1											
Outer Thread Size (Male)	Inner Thread Size (Female)	Clamping Range		Outer Thread Length TL mm	Inner Thread Length ITL mm	Cap SW Cap mm	Spanner Width Upper Body		Outer Ø D mm	max. Height H mm	Part Number
		Ø min-max mm	Seal Type				SW Upper Body mm	SW Lower Body mm			
NPT 3/8"	NPT 3/8"	4,0 - 12,0	Triple	16,0	16,0	27	27	22	30,0	56,5	EBMS01N01N
	NPT 1/2"	4,0 - 12,0	Triple	16,0	16,0	27	27	22	30,0	56,0	EBMS01N12N
NPT 1/2"	NPT 3/8"	4,0 - 12,0	Triple	16,0	16,0	27	27	22	30,0	52,0	EBMS12N01N
	NPT 1/2"K	4,0 - 12,0	Triple	16,0	16,0	27	27	22	30,0	52,0	EBMS1N1N
	NPT 1/2"	10,0 - 16,0	Triple	16,0	16,0	32	32	28	35,5	54,5	EBMS12N12N
	NPT 3/4"	10,0 - 16,0	Triple	16,0	16,0	32	32	28	35,5	56,5	EBMS12N23N
NPT 3/4"	NPT 1/2"	10,0 - 16,0	Triple	16,0	16,0	32	32	28	35,5	54,5	EBMS23N12N
	NPT 3/4"K	10,0 - 18,0	Triple	16,0	16,0	32	32	28	35,5	56,5	EBMS2N2N
	NPT 3/4"	14,0 - 20,0	Triple	16,0	16,0	40	40	35	44,5	58,5	EBMS23N23N
	NPT 1"	14,0 - 20,0	Triple	16,0	20,0	40	40	35	44,5	64,5	EBMS23N34N
NPT 1"	NPT 3/4"	14,0 - 20,0	Triple	20,0	16,0	40	40	35	44,5	58,5	EBMS34N23N
	NPT 1"	14,0 - 24,0	Triple	20,0	20,0	40	40	35	44,5	64,0	EBMS3N3N
	NPT 1"	22,0 - 26,0	Triple	20,0	20,0	48	45	45	53,3	68,0	EBMS34N34N
	NPT 1 1/4"	22,0 - 26,0	Triple	20,0	20,0	48	45	45	53,3	68,0	EBMS34N45N
NPT 1 1/4"	NPT 1"	22,0 - 26,0	Triple	20,0	20,0	48	45	45	53,3	69,0	EBMS45N34N
	NPT 1 1/4"K	22,0 - 32,0	Triple	20,0	20,0	48	45	45	53,3	69,0	EBMS4N4N
	NPT 1 1/4"	26,0 - 34,0	Triple	20,0	20,0	55	55	55	61,0	76,0	EBMS45N45N
	NPT 1 1/2"	26,0 - 34,0	Triple	20,0	20,0	55	55	55	61,0	76,0	EBMS45N56N
NPT 1 1/2"	NPT 1 1/4"	26,0 - 34,0	Triple	20,0	20,0	55	55	55	61,0	76,0	EBMS56N45N
	NPT 1 1/2"K	26,0 - 35,0	Triple	20,0	20,0	55	55	55	61,0	76,0	EBMS5N5N
	NPT 1 1/2"	35,0 - 41,0	Triple	20,0	20,0	64	64	64	70,0	75,5	EBMS56N56N
	NPT 2"	35,0 - 41,0	Triple	20,0	20,0	80	80	64	89,0	85,5	EBMS56N67N
NPT 2"	NPT 1 1/2"	35,0 - 41,0	Triple	20,0	20,0	64	64	68	75,0	75,5	EBMS67N56N
	NPT 2"K	35,0 - 45,0	Triple	20,0	20,0	64	64	68	75,0	77,0	EBMS6N6N
	NPT 2"	46,0 - 52,0	Triple	20,0	20,0	80	80	75	89,0	85,5	EBMS67N67N
	NPT 2 1/2"	46,0 - 52,0	Triple	20,0	21,0	95	95	75	105,0	90,0	EBMS67N78N
NPT 2 1/2"	NPT 2"	46,0 - 52,0	Triple	21,0	20,0	80	80	80	89,0	85,5	EBMS78N67N
	NPT 2 1/2"K	46,0 - 62,0	Triple	21,0	21,0	80	80	80	89,0	86,5	EBMS7N7N
	NPT 2 1/2"	60,0 - 64,0	Triple	21,0	21,0	95	95	95	105,0	90,0	EBMS78N78N
	NPT 3"	60,0 - 64,0	Triple	21,0	21,0	105	105	95	117,0	90,0	EBMS78N810N
NPT 3"	NPT 2 1/2"	60,0 - 64,0	Triple	21,0	21,0	95	95	95	105,0	90,0	EBMS810N78N
	NPT 3"K	60,0 - 75,0	Triple	21,0	21,0	95	95	95	105,0	90,0	EBMS8N8N
	NPT 3"	75,0 - 79,5	Triple	21,0	21,0	105	105	105	117,0	90,0	EBMS810N810N
	NPT 4"K	75,0 - 79,5	Triple	21,0	21,0	115	115	105	128,0	90,0	EBMS810N10N
NPT 4"	NPT 3"	75,0 - 79,5	Triple	21,0	21,0	105	105	115	128,0	90,0	EBMS11N810N
	NPT 4"K	75,0 - 85,0	Triple	21,0	21,0	115	115	115	128,0	90,0	EBMS10N10N
	NPT 4"	85,0 - 95,0	Triple	21,0	21,0	115	115	115	128,0	91,0	EBMS11N11N

Rigid Conduit Swivel Fittings with Multihole Seal for Ex d/e applications

PHOENIX



Technical Details			
Material	Body	Brass, Brass Nickel Plated, Stainless Steel 316L	
	Inner Parts	Stainless Steel	
	Seal	Silicone	
	O-ring	Silicone	
Ingress Protection Rating	IP 68 - 5 Bar, 30 min IP 66		
Operating Temperature	Seal Material	Silicone	
	Ex e/tb	-60°C to +80°C	
Equipment For	Gas & Dust potentially explosive atmospheres		
Suitable for use in	Group II	Gas Group IIC	ZONE1/ZONE2
	Group III	Dust Group IIC	ZONE21/ZONE 22
Equipment Marking	Ex II 2GD Ex eb IIC Gb Ex tb IIIC Db		
Marking Example *	BMD SV.. CE 0722 II 2GD Ex eb IIC Gb Ex tb IIIC Db Ta-60°C +80°C IP66/68 IECEx IMQ 14.0002X IMQ 13 ATEX 029X		
Thread Type	<ul style="list-style-type: none"> • Metric (M) ISO Pitch 1,5 • Npt (N) ANSI ASME B1.20.1 • Other thread types also available upon request. • Other combinations: Metric-Metric/Npt-Npt/Npt-Metric 		
Cable Type	Non Armour		
Accessories	<ul style="list-style-type: none"> • Lock nuts • Gaskets (Washers) • Serrated Washers • Earth tags 		
Remarks	<ul style="list-style-type: none"> • Accessories must be ordered separately. • O-ring only available when male thread is Metric. 		
Approvals	Certificate Number	Standards	
	IMQ 13 ATEX 029X	EN 60079-0:2012+A11:2013 EN 60079-7:2015 EN 60079-31:2014	
	IECEx IMQ 14.0002X	IEC 60079-0:2011 Edition:6 IEC 60079-7:2015 Edition:5 IEC 60079-31:2013 Edition:2	
	№ TC RU C-TR.AA87.B.00941	ГОСТ 31610.0-2014 ГОСТ IEC 60079-1:2013 ГОСТ IEC 60079-31:2013	
	E-14044	IEC/EN60079-0, IEC/EN60079-7, IEC/EN60079-31, IEC/EN60079-1, IEC/EN 62444	

-For more information see our webpage.

* The standard marking consists ATEX & IECEx only. Marking acc. to other standards on request.



Order Coding									
Part Number #1	No. of Cores	Part Number #2	Material	Seal	Gasket (Washers)	Serrated Washer	Lock Nut	Earth Tag	
Mandatory	Mandatory	Mandatory	Mandatory	Mandatory	- Option	Option	Option	Option	
See table	See table	See table	B Brass BN Brass Nickel plated X Stainless steel 316L	S Silicone	- WC Chloroprene WS Silicone WF Fiber	WSR Serrated washer	L Lock nut	E Earth tag	
Example									
SV	4	H301M1M	BN	S	- WC	WSR	L	E	

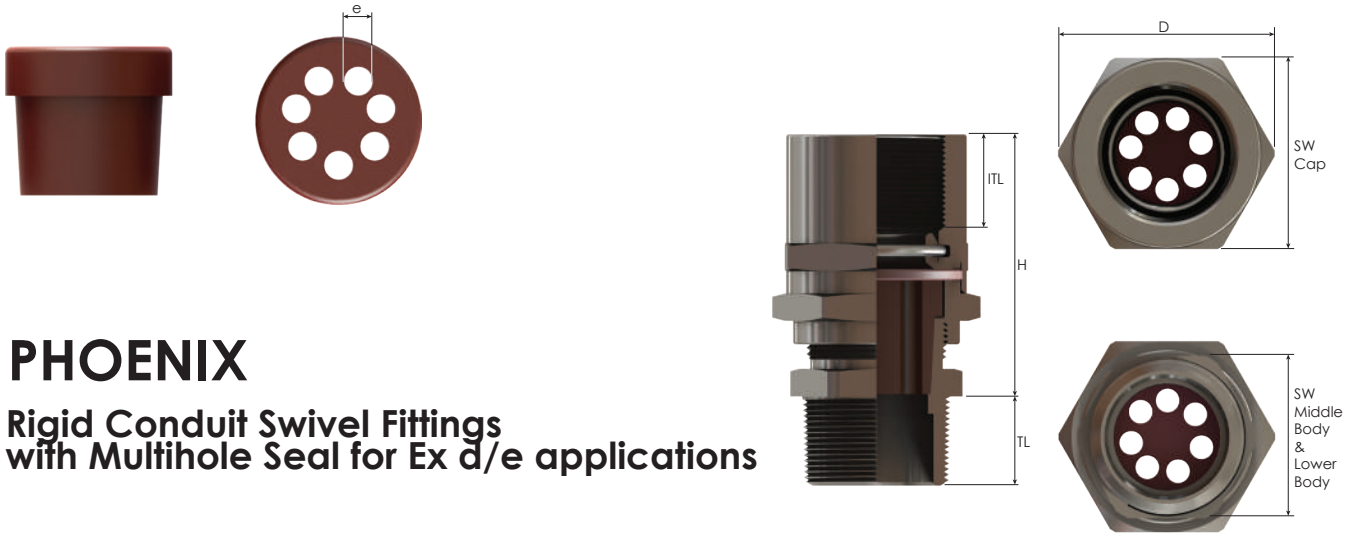

PHOENIX

Rigid Conduit Swivel Fittings with Multihole Seal for Ex d/e applications

Thread Type **METRIC** acc. to ISO 965-3 and NPT acc. to ANSI ASME B1.20.1

Outer Thread Size (Male)	Inner Thread Size (Female)	max. Number of Cores n	Core Ø e mm	Outer Thread Length TL mm	Inner Thread Length ITL mm	Spanner Width			Outer Ø D mm	max. Height H mm	Part Number		
						Cap	Middle Body	Lower Body			#1	#2	
						SW Cap mm	SW Middle Body mm	SW Lower Body mm					
M20x1,5	M20x1,5	7	2,5	11,0	16,0	33	33	28	37,5	50,0	SV	H251M1M	
		4	3,0	11,0	16,0	33	33	28	37,5	50,0	SV	H301M1M	
	M25x1,5	7	2,5	11,0	16,0	33	33	28	37,5	50,0	SV	H251M2M	
		4	3,0	11,0	16,0	33	33	28	37,5	50,0	SV	H301M2M	
		NPT 3/4"	7	2,5	11,0	17,0	33	33	28	37,5	50,0	SV	H251M2N
4	3,0		11,0	17,0	33	33	28	37,5	50,0	SV	H301M2N		
M25x1,5	M20x1,5	7	2,5	11,0	16,0	33	33	28	37,5	48,0	SV	H252M1M	
		4	3,0	11,0	16,0	33	33	28	37,5	48,0	SV	H302M1M	
		3	3,6	11,0	16,0	33	33	28	37,5	48,0	SV	H362M1M	
		7	4,0	11,0	16,0	33	33	28	37,5	48,0	SV	H402M1M	
	M25x1,5	M25x1,5	7	2,5	11,0	16,0	33	33	28	37,5	48,0	SV	H252M2M
			4	3,0	11,0	16,0	33	33	28	37,5	48,0	SV	H302M2M
			3	3,6	11,0	16,0	33	33	28	37,5	48,0	SV	H362M2M
	NPT 3/4"	M25x1,5	7	4,0	11,0	16,0	33	33	28	37,5	48,0	SV	H402M2M
			7	2,5	11,0	17,0	33	33	28	37,5	48,0	SV	H252M2N
			4	3,0	11,0	17,0	33	33	28	37,5	48,0	SV	H302M2N
			3	3,6	11,0	17,0	33	33	28	37,5	48,0	SV	H362M2N
NPT 3/4"	M20x1,5	7	2,5	16,0	16,0	33	33	28	37,5	48,0	SV	H252N1M	
		4	3,0	16,0	16,0	33	33	28	37,5	48,0	SV	H302N1M	
		3	3,6	16,0	16,0	33	33	28	37,5	48,0	SV	H362N1M	
		7	4,0	16,0	16,0	33	33	28	37,5	48,0	SV	H402N1M	
	M25x1,5	M25x1,5	7	2,5	16,0	16,0	33	33	28	37,5	48,0	SV	H252N2M
			4	3,0	16,0	16,0	33	33	28	37,5	48,0	SV	H302N2M
			3	3,6	16,0	16,0	33	33	28	37,5	48,0	SV	H362N2M
	NPT 3/4"	M25x1,5	7	4,0	16,0	16,0	33	33	28	37,5	48,0	SV	H402N2M
			7	2,5	16,0	17,0	33	33	28	37,5	48,0	SV	H252N2N
			4	3,0	16,0	17,0	33	33	28	37,5	48,0	SV	H302N2N
NPT 3/4"	NPT 3/4"	3	3,6	16,0	17,0	33	33	28	37,5	48,0	SV	H362N2N	
		7	4,0	16,0	17,0	33	33	28	37,5	48,0	SV	H402N2N	



bimed

Liquid Tight and Flexible Conduit Fittings for Gas & Dust Application



E-Hydrus	164 - 165
E-Scorpius	166 - 167
E-Lupus	168 - 169
E-Corvus	170 - 171

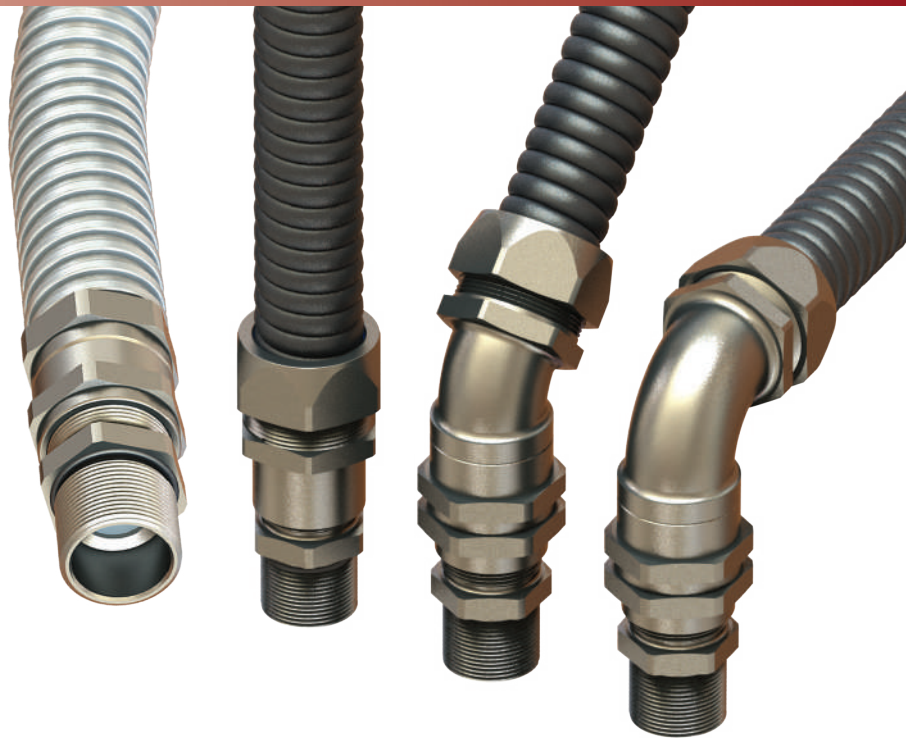

Ex Fittings / Group II-III / Gas & Dust Ex II 2GD / Ex d IIC Gb - Ex e IIC Gb - Ex tb IIIC Db



Typical applications for liquidtight conduit and liquidtight fittings include the wiring of machine tools, motors, transformers, food processing equipment, robotics, air conditioning units, illuminated store front signs and billboards, etc. The flexible metallic conduit and fittings protect conductors from mechanical damage due to vibration and movement, and seal out cutting oils, coolants, water, dust, etc. Applications such as these can be found in, but are not limited to, industries such as:

- Machine tool manufacturers
- Electric power generating plants
- Waste treatment facilities
- Paint manufacturing facilities
- Automobile manufacturing facilities
- Aerospace industries
- Breweries
- Food processing plants
- Dairies
- Pulp and paper mills
- Petroleum refineries
- Chemical and petrochemical plants

Fittings for Flexible Conduits for Non-armoured Cables

E-HYDRUS

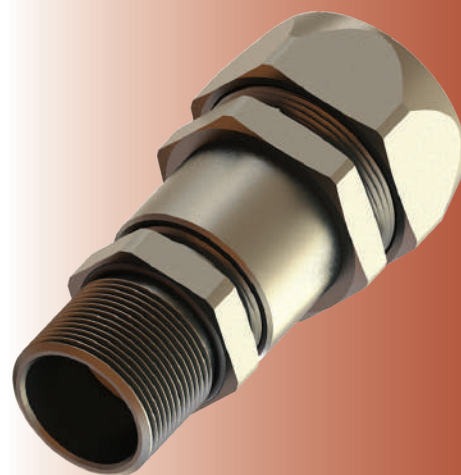

Technical Details		
Body, Cap	Brass, Brass Nickel Plated, Stainless Steel 316L	
Seal	CR (Chloroprene), Silicone	
Material	Ferrule Steel Zinc Plated, Brass Nickel Plated	
	Plastic Ring Polyamide	
	O-ring CR (Chloroprene), Silicone	
Ingress Protection Rating	IP 68 - 5 Bar, 30 min IP 66	
Operating Temperature	Seal Material	
	CR (Chloroprene)	
Ex d/tb	-40°C to +80°C	Silicone
Ex e/tb	-40°C to +80°C	-60°C to +80°C
		-60°C to +140°C
Equipment For	Gas & Dust potentially explosive atmospheres	
Suitable for use in	Group II Group III	Gas Group IIC Dust Group IIIC
		ZONE1/ZONE2 ZONE21/ZONE 22
Equipment Marking	Ex II 2GD Ex db IIC Gb Ex eb IIC Gb Ex tb IIIC Db	
Marking Example *	BMD EBLs.. CE 0722 II 2GD Ex db IIC Gb Ex eb IIC Gb Ex tb IIIC Db Ta-40°C +80°C IP66/68 CESI 13 ATEX 018X IECEx CES 13.0006X	
Thread Type	<ul style="list-style-type: none"> • Metric (M) ISO Pitch 1,5 • NPT (N) ANSI ASME B1.20.1 • Other thread types also available upon request. 	
Cable Type	Non Armoured	
Accessories	<ul style="list-style-type: none"> • Lock nuts • Gaskets (Washers) • Serrated Washers • Earth tags 	
Remarks	<ul style="list-style-type: none"> • Accessories must be ordered separately. • O-ring available in Metric outer threads. 	
Approvals	Certificate Number	Standards
	IMQ 13 ATEX 018X	EN 60079-0:2012+A11:2013 EN 60079-7:2015 EN 60079-31:2014 EN 60079-1:2014
	IECEx IMQ 13.0006X	IEC 60079-0:2011 Edition:6 IEC 60079-7:2015 Edition:5 IEC 60079-31:2013 Edition:2 IEC 60079-1:2014 Edition:7
	№ TC RU C-TR.AA87.B.00941	ГОСТ 31610.0-2014 ГОСТ IEC 60079-1:2013 ГОСТ IEC 60079-31:2013
	DNV 12.0052 X	ABNT NBR IEC 60079-0:2013 ABNT NBR IEC 60079-1:2009 ABNT NBR IEC 60079-7:2008 ABNT NBR IEC 60079-31:2011
	E-14044	IEC/EN60079-0 IEC/EN60079-7 IEC/EN60079-31 IEC/EN60079-1 IEC/EN 62444

-For more information see our webpage.

* The standard marking consists ATEX & IECEx only. Marking acc. to other standards on request.

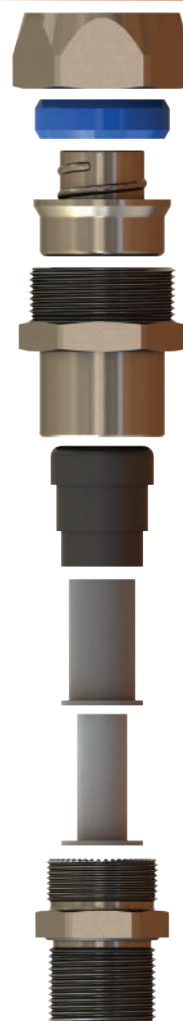

Order Coding							
Part Number	Material	Seal	Gasket (Washer)	Serrated Washer	Lock Nut	Earth Tag	for Ex e
See table	Mandatory	Mandatory	- Option	Option	Option	Option	Option
	B Brass	C Chloroprene	- WC Chloroprene	WSR Serrated washer	L Lock nut	E Earth tag	TL9
	BN Brass Nickel plated	S Silicone	WS Silicone				
	X Stainless steel 316L		WF Fiber				
Example							
EBLS01M	BN	S	- WC	-	L	E	TL9

E-HYDRUS

Fittings for Flexible Conduits for Non-armoured Cables

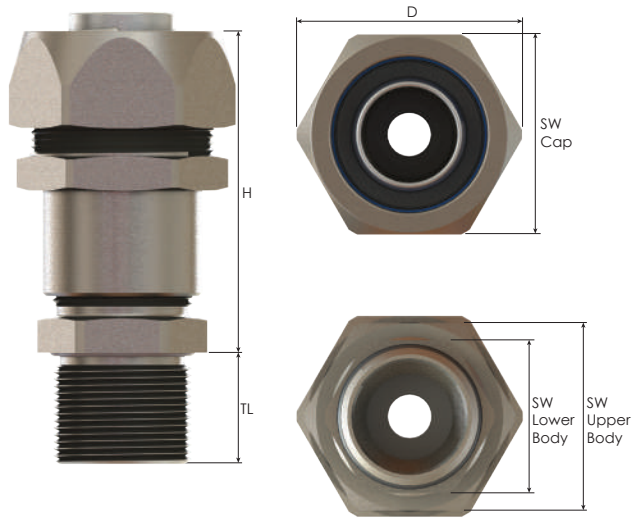

Thread Type METRIC acc. to ISO 965-3

Outer Thread Size (Male)	For Seal/Title Nominal Size	Clamping Range		Outer Thread Length		Cap	Spanner Width		Outer Ø	max. Height	Part Number
		Ø min-max mm	Seal Type	Ex - e min.	Ex-d/e min.		Upper Body	Lower Body			
				TL mm		SW Cap mm	SW Upper Body mm	SW Lower Body mm	D mm	H mm	
M12x1,5	1/2 "	4,0 - 8,0	Triple	9,0	16,0	29	27	22	32,7	57,0	*EBLS02M
M16x1,5	1/2 "	4,0 - 12,0	Triple	9,0	16,0	29	27	22	32,7	57,0	EBLS01M
M20x1,5	3/8 "	4,0 - 10,0	Triple	9,0	16,0	26	24	22	29,0	50,5	EBLS1SM
	1/2 "	4,0 - 12,0	Triple	9,0	16,0	29	27	22	32,7	53,0	EBLS1M
M25x1,5	3/4 "	10,0 - 18,0	Triple	9,0	16,0	35	33	28	39,0	56,0	EBLS2M
M32x1,5	1 "	14,0 - 24,0	Triple	9,0	16,0	45	43	35	50,0	64,0	EBLS3M
M40x1,5	1 1/4 "	22,0 - 32,0	Triple	9,0	18,0	54	52	45	60,0	75,0	EBLS4M
M50x1,5	1 1/2 "	26,0 - 35,0	Triple	9,0	18,0	63	60	55	69,3	81,5	EBLS5M

Thread Type NPT acc. to ANSI ASME B1.20.1

Outer Thread Size (Male)	For Seal/Title Nominal Size	Clamping Range		Outer Thread Length		Cap	Spanner Width		Outer Ø	max. Height	Part Number
		Ø min-max mm	Seal Type	TL mm			Upper Body	Lower Body			
				TL mm		SW Cap mm	SW Upper Body mm	SW Lower Body mm	D mm	H mm	
NPT 1/4"	1/2 "	4,0 - 8,0	Triple	16,0		29	27	22	32,7	57,0	*EBLS02N
NPT 3/8"	1/2 "	4,0 - 12,0	Triple	16,0		29	27	22	32,7	57,0	EBLS01N
NPT 1/2"	3/8 "	4,0 - 10,0	Triple	16,0		26	24	22	29,0	50,5	EBLS1SN
	1/2 "	4,0 - 12,0	Triple	16,0		29	27	22	32,7	53,0	EBLS1N
NPT 3/4"	3/4 "	10,0 - 18,0	Triple	16,0		35	33	28	39,0	55,5	EBLS2N
NPT 1"	1 "	14,0 - 24,0	Triple	20,0		45	43	35	50,0	64,0	EBLS3N
NPT 1 1/4"	1 1/4 "	22,0 - 32,0	Triple	20,0		54	52	45	60,0	75,0	EBLS4N
NPT 1 1/2"	1 1/2 "	26,0 - 35,0	Triple	20,0		63	60	55	69,3	81,5	EBLS5N

45° Fittings for Flexible Conduits for Non-armoured Cables

E-SCORPIUS

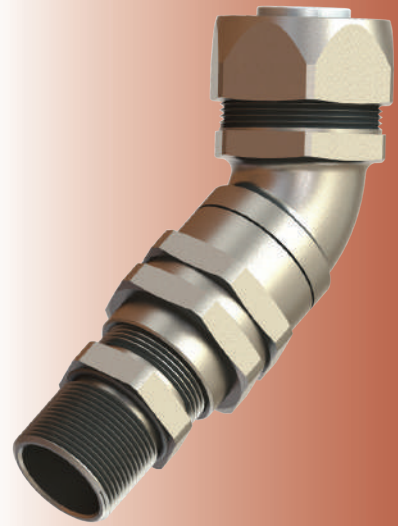

Technical Details	
Material	Body, Cap Brass, Brass Nickel Plated, Stainless Steel 316L Seal CR (Chloroprene), Silicone Ferrule Steel Zinc Plated, Brass Nickel Plated Plastic Ring Polyamide O-ring CR (Chloroprene), Silicone
Ingress Protection Rating	IP 68 - 5 Bar, 30 min IP 66
Operating Temperature	Seal Material CR (Chloroprene) -40°C to +80°C Silicone -60°C to +80°C
Equipment For	Gas & Dust potentially explosive atmospheres
Suitable for use in	Group II Gas Group IIC ZONE1/ZONE2 Group III Dust Group IIIC ZONE21/ZONE 22
Equipment Marking	Ex II 2GD Ex db IIC Gb Ex eb IIC Gb Ex tb IIIC Db
Marking Example *	BMD EBLQ.. CE 0722 II 2GD Ex db IIC Gb Ex eb IIC Gb Ex tb IIIC Db Ta-40°C +80°C IP66/68 CESI 13 ATEX 018X IECEx CES 13.0006X
Thread Type	• Metric (M) ISO Pitch 1,5 • NPT (N) ANSI ASME B1.20.1 • Other thread types also available upon request.
Cable Type	Non Armoured
Accessories	• Lock nuts • Gaskets (Washers) • Serrated Washers • Earth tags
Remarks	• Accessories must be ordered separately. • O-ring available in Metric outer threads.
Approvals	Certificate Number Standards
	IMQ 13 ATEX 018X EN 60079-0:2012+A11:2013 EN 60079-7:2015 EN 60079-31:2014 EN 60079-1:2014
	IECEx IMQ 13.0006X IEC 60079-0:2011 Edition:6 IEC 60079-7:2015 Edition:5 IEC 60079-31:2013 Edition:2 IEC 60079-1:2014 Edition:7
	№ TC RU C-TR.AA87.B.00941 GOCT 31610.0-2014 GOCT IEC 60079-1:2013 GOCT IEC 60079-31:2013
	DNV 12.0052 X ABNT NBR IEC 60079-0:2013 ABNT NBR IEC 60079-1:2009 ABNT NBR IEC 60079-7:2008 ABNT NBR IEC 60079-31:2011
	E-14044 IEC/EN60079-0 IEC/EN60079-7 IEC/EN60079-31 IEC/EN60079-1 IEC/EN 62444

-For more information see our webpage.

* The standard marking consists ATEX & IECEx only. Marking acc. to other standards on request.

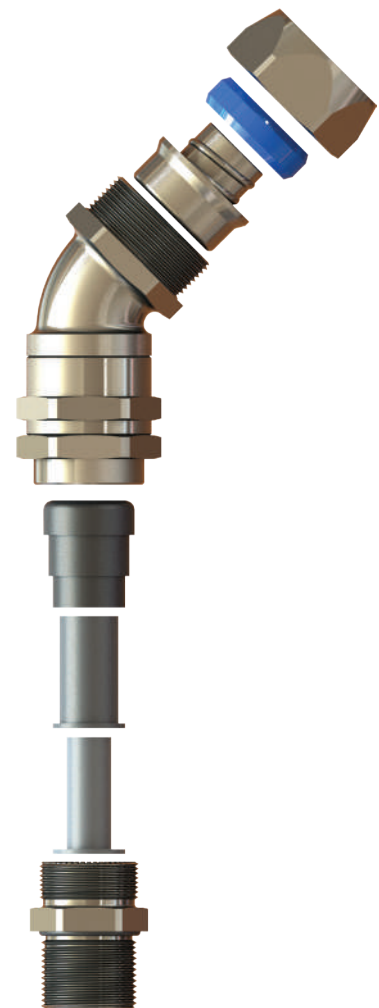

Order Coding								
Part Number	Material	Seal	-	Gasket (Washer)	Serrated Washer	Lock Nut	Earth Tag	for Ex e
See table	Mandatory	Mandatory	-	Option	Option	Option	Option	Option
	B Brass BN Brass Nickel plated X Stainless steel 316L	C Chloroprene S Silicone	-	WC Chloroprene WS Silicone WF Fiber	WSR Serrated washer	L Lock nut	E Earth tag	TL9
Example								
EBLQ01M	BN	S	-	WC	WSR	L	E	TL9

E-SCORPIUS

45° Fittings for Flexible Conduits for Non-armoured Cables

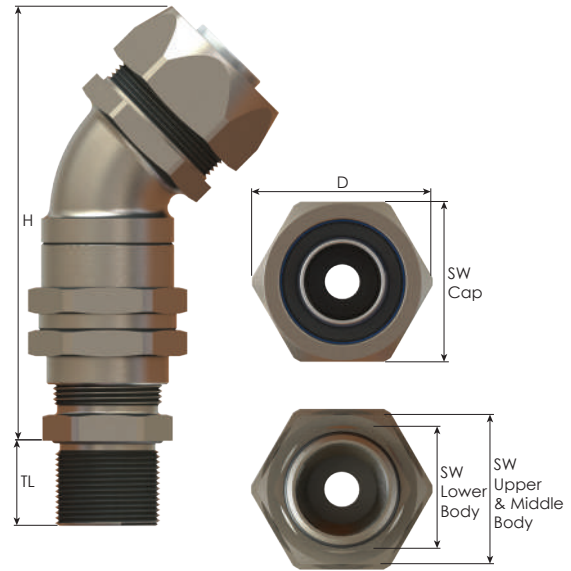

Thread Type METRIC acc. to ISO 965-3

Outer Thread Size (Male)	For Sealtite Nominal Size	Clamping Range		Outer Thread Length		Spanner Width				Outer Ø	max. Height	Part Number
		Ø min-max mm	Seal Type	Ex - e min.	Ex-d/e min.	Cap	Upper Body	Middle Body	Lower Body			
				TL mm		SW Cap mm	SW Upper Body mm	SW Middle Body mm	SW Lower Body mm	D mm	H mm	
M12x1,5	1/2 "	4,0 - 8,0	Triple	9,0	16,0	29	27	27	22	32,7	89,0	*EBLQ02M
M16x1,5	1/2 "	4,0 - 12,0	Triple	9,0	16,0	29	27	27	22	32,7	89,0	EBLQ01M
M20x1,5	3/8 "	4,0 - 10,0	Triple	9,0	16,0	26	22	27	22	29,0	83,0	EBLQ15M
	1/2 "	4,0 - 12,0	Triple	9,0	16,0	29	27	27	22	32,7	85,0	EBLQ11M
M25x1,5	3/4 "	10,0 - 18,0	Triple	9,0	16,0	35	33	33	28	39,0	96,5	EBLQ2M
M32x1,5	1 "	14,0 - 24,0	Triple	9,0	16,0	45	42	42	35	50,0	113,5	EBLQ3M
M40x1,5	1 1/4 "	22,0 - 32,0	Triple	9,0	18,0	54	51	51	45	60,0	135,0	EBLQ4M
M50x1,5	1 1/2 "	26,0 - 35,0	Triple	9,0	18,0	63	60	60	55	69,3	147,5	EBLQ5M

Thread Type NPT acc. to ANSI ASME B1.20.1

Outer Thread Size (Male)	For Sealtite Nominal Size	Clamping Range		Outer Thread Length	Spanner Width				Outer Ø	max. Height	Part Number
		Ø min-max mm	Seal Type		Cap	Upper Body	Middle Body	Lower Body			
				TL mm	SW Cap mm	SW Upper Body mm	SW Middle Body mm	SW Lower Body mm	D mm	H mm	
NPT 1/4"	1/2 "	4,0 - 8,0	Triple	16,0	29	27	27	22	32,7	89,0	*EBLQ02N
NPT 3/8"	1/2 "	4,0 - 12,0	Triple	16,0	29	27	27	22	32,7	89,0	EBLQ01N
NPT 1/2"	3/8 "	4,0 - 10,0	Triple	16,0	26	22	27	22	29,0	83,0	EBLQ15N
	1/2 "	4,0 - 12,0	Triple	16,0	29	27	27	22	32,7	85,0	EBLQ11N
NPT 3/4"	3/4 "	10,0 - 18,0	Triple	16,0	35	33	33	28	39,0	96,0	EBLQ2N
NPT 1"	1 "	14,0 - 24,0	Triple	20,0	45	42	42	35	50,0	113,5	EBLQ3N
NPT 1 1/4"	1 1/4 "	22,0 - 32,0	Triple	20,0	54	51	51	45	60,0	135,0	EBLQ4N
NPT 1 1/2"	1 1/2 "	26,0 - 35,0	Triple	20,0	63	60	60	55	69,3	147,5	EBLQ5N

90° Fittings for Flexible Conduits for Non-Armoured Cables

E-LUPUS



Technical Details													
Material	<table border="0"> <tr> <td>Body, Cap</td> <td>Brass, Brass Nickel Plated, Stainless Steel 316L</td> </tr> <tr> <td>Seal</td> <td>CR (Chloroprene), Silicone</td> </tr> <tr> <td>Ferrule</td> <td>Steel Zinc Plated, Brass Nickel Plated</td> </tr> <tr> <td>Plastic Ring</td> <td>Polyamide</td> </tr> <tr> <td>O-ring</td> <td>CR (Chloroprene), Silicone</td> </tr> </table>	Body, Cap	Brass, Brass Nickel Plated, Stainless Steel 316L	Seal	CR (Chloroprene), Silicone	Ferrule	Steel Zinc Plated, Brass Nickel Plated	Plastic Ring	Polyamide	O-ring	CR (Chloroprene), Silicone		
Body, Cap	Brass, Brass Nickel Plated, Stainless Steel 316L												
Seal	CR (Chloroprene), Silicone												
Ferrule	Steel Zinc Plated, Brass Nickel Plated												
Plastic Ring	Polyamide												
O-ring	CR (Chloroprene), Silicone												
Ingress Protection Rating	IP 68 - 5 Bar, 30 min IP 66												
Operating Temperature	<table border="0"> <tr> <td>Seal Material</td> <td>CR (Chloroprene)</td> <td>Silicone</td> </tr> <tr> <td>Ex d/tb</td> <td>-40°C to +80°C</td> <td>-60°C to +80°C</td> </tr> <tr> <td>Ex e/tb</td> <td>-40°C to +80°C</td> <td>-60°C to +140°C</td> </tr> </table>	Seal Material	CR (Chloroprene)	Silicone	Ex d/tb	-40°C to +80°C	-60°C to +80°C	Ex e/tb	-40°C to +80°C	-60°C to +140°C			
Seal Material	CR (Chloroprene)	Silicone											
Ex d/tb	-40°C to +80°C	-60°C to +80°C											
Ex e/tb	-40°C to +80°C	-60°C to +140°C											
Equipment For	Gas & Dust potentially explosive atmospheres												
Suitable for use in	Group II Gas Group IIC ZONE1/ZONE2 Group III Dust Group IIIC ZONE21/ZONE 22												
Equipment Marking	Ex II 2GD Ex db IIC Gb Ex eb IIC Gb Ex tb IIIC Db												
Marking Example *	BMD EBLN.. CE 0722 II 2GD Ex db IIC Gb Ex eb IIC Gb Ex tb IIIC Db Ta-40°C +80°C IP66/68 CESI 13 ATEX 018X IECEx CES 13.0006X												
Thread Type	<ul style="list-style-type: none"> • Metric (M) ISO Pitch 1,5 • NPT (N) ANSI ASME B1.20.1 • Other thread types also available upon request. 												
Cable Type	Non Armoured												
Accessories	<ul style="list-style-type: none"> • Lock nuts • Gaskets (Washers) • Serrated Washers • Earth tags 												
Remarks	<ul style="list-style-type: none"> • Accessories must be ordered separately. • O-ring available in Metric outer threads. 												
Approvals	<table border="0"> <tr> <th>Certificate Number</th> <th>Standards</th> </tr> <tr> <td> IMQ 13 ATEX 018X</td> <td>EN 60079-0:2012+A11:2013 EN 60079-7:2015 EN 60079-31:2014 EN 60079-1:2014</td> </tr> <tr> <td> IECEx IMQ 13.0006X</td> <td>IEC 60079-0:2011 Edition:6 IEC 60079-7:2015 Edition:5 IEC 60079-31:2013 Edition:2 IEC 60079-1:2014 Edition:7</td> </tr> <tr> <td> № TC RU C-TR.AA87.B.00941</td> <td>ГОСТ 31610.0-2014 ГОСТ IEC 60079-1:2013 ГОСТ IEC 60079-31:2013</td> </tr> <tr> <td> DNV 12.0052 X</td> <td>ABNT NBR IEC 60079-0:2013 ABNT NBR IEC 60079-1:2009 ABNT NBR IEC 60079-7:2008 ABNT NBR IEC 60079-31:2011</td> </tr> <tr> <td> E-14044</td> <td>IEC/EN60079-0 IEC/EN60079-7 IEC/EN60079-31 IEC/EN60079-1 IEC/EN 62444</td> </tr> </table>	Certificate Number	Standards	IMQ 13 ATEX 018X	EN 60079-0:2012+A11:2013 EN 60079-7:2015 EN 60079-31:2014 EN 60079-1:2014	IECEx IMQ 13.0006X	IEC 60079-0:2011 Edition:6 IEC 60079-7:2015 Edition:5 IEC 60079-31:2013 Edition:2 IEC 60079-1:2014 Edition:7	№ TC RU C-TR.AA87.B.00941	ГОСТ 31610.0-2014 ГОСТ IEC 60079-1:2013 ГОСТ IEC 60079-31:2013	DNV 12.0052 X	ABNT NBR IEC 60079-0:2013 ABNT NBR IEC 60079-1:2009 ABNT NBR IEC 60079-7:2008 ABNT NBR IEC 60079-31:2011	E-14044	IEC/EN60079-0 IEC/EN60079-7 IEC/EN60079-31 IEC/EN60079-1 IEC/EN 62444
Certificate Number	Standards												
IMQ 13 ATEX 018X	EN 60079-0:2012+A11:2013 EN 60079-7:2015 EN 60079-31:2014 EN 60079-1:2014												
IECEx IMQ 13.0006X	IEC 60079-0:2011 Edition:6 IEC 60079-7:2015 Edition:5 IEC 60079-31:2013 Edition:2 IEC 60079-1:2014 Edition:7												
№ TC RU C-TR.AA87.B.00941	ГОСТ 31610.0-2014 ГОСТ IEC 60079-1:2013 ГОСТ IEC 60079-31:2013												
DNV 12.0052 X	ABNT NBR IEC 60079-0:2013 ABNT NBR IEC 60079-1:2009 ABNT NBR IEC 60079-7:2008 ABNT NBR IEC 60079-31:2011												
E-14044	IEC/EN60079-0 IEC/EN60079-7 IEC/EN60079-31 IEC/EN60079-1 IEC/EN 62444												

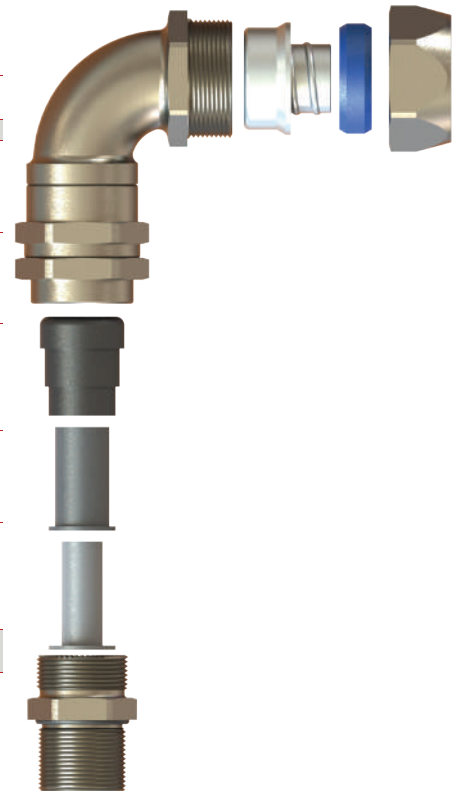

-For more information see our webpage.
* The standard marking consists ATEX & IECEx only. Marking acc. to other standards on request.

Order Coding								
Part Number	Material	Seal	-	Gasket (Washer)	Serrated Washer	Lock Nut	Earth Tag	for Ex e
See table	Mandatory	Mandatory	-	Option	Option	Option	Option	Option
	B Brass BN Brass Nickel plated X Stainless steel 316L	C Chloroprene S Silicone	-	WC Chloroprene WS Silicone WF Fiber	WSR Serrated washer	L Lock nut	E Earth tag	TL9
Example	EBLN3M	BN	S	WC	WSR	L	E	TL9

E-LUPUS

90° Fittings for Flexible Conduits for Non-Armoured Cables

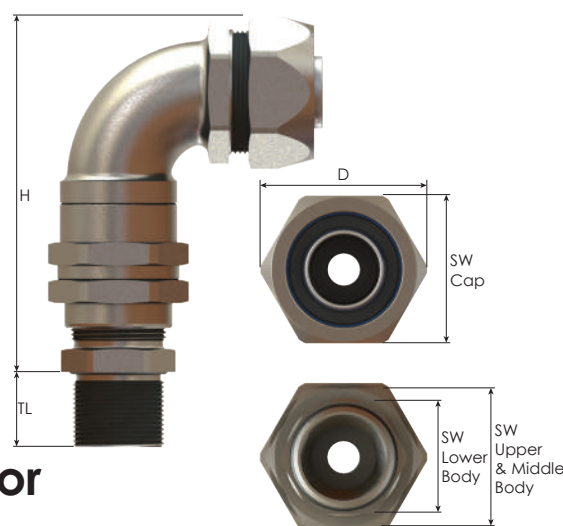

Thread Type METRIC acc. to ISO 965-3

Outer Thread Size (Male)	For Sealtite Nominal Size	Clamping Range		Outer Thread Length		Cap	Spanner Width			Outer Ø	max. Height	Part Number
		Ø min-max mm	Seal Type	Ex-e min.	Ex-d/e min.		Upper Body	Middle Body	Lower Body			
				TL mm		SW Cap mm	SW Upper Body mm	SW Middle Body mm	SW Lower Body mm	D mm	H mm	
M12x1,5	1/2"	4,0 - 8,0	Triple	9,0	16,0	29	27	27	22	32,7	83,5	*EBLN02M
M16x1,5	1/2"	4,0 - 12,0	Triple	9,0	16,0	29	27	27	22	32,7	83,5	EBLN01M
M20x1,5	3/8"	4,0 - 10,0	Triple	9,0	16,0	26	22	27	22	29,0	75,0	EBLN1SM
	1/2"	4,0 - 12,0	Triple	9,0	16,0	29	27	27	22	32,7	80,0	EBLN1M
M25x1,5	3/4"	10,0 - 18,0	Triple	9,0	16,0	35	33	33	28	39,0	90,0	EBLN2M
M32x1,5	1"	14,0 - 24,0	Triple	9,0	16,0	45	42	42	35	50,0	104,0	EBLN3M
M40x1,5	1 1/4"	22,0 - 32,0	Triple	9,0	18,0	54	51	51	45	60,0	122,0	EBLN4M
M50x1,5	1 1/2"	26,0 - 35,0	Triple	9,0	18,0	63	60	60	55	69,3	137,0	EBLN5M

Thread Type NPT acc. to ANSI ASME B1.20.1

Outer Thread Size (Male)	For Sealtite Nominal Size	Clamping Range		Outer Thread Length	Cap	Spanner Width			Outer Ø	max. Height	Part Number
		Ø min-max mm	Seal Type			Upper Body	Middle Body	Lower Body			
				TL mm	SW Cap mm	SW Upper Body mm	SW Middle Body mm	SW Lower Body mm	D mm	H mm	
NPT 1/4"	1/2"	4,0 - 8,0	Triple	16,0	29	27	27	22	32,7	83,5	*EBLN02N
NPT 3/8"	1/2"	4,0 - 12,0	Triple	16,0	29	27	27	22	32,7	83,5	EBLN01N
NPT 1/2"	3/8"	4,0 - 10,0	Triple	16,0	26	22	27	22	29,0	75,0	EBLN1SN
	1/2"	4,0 - 12,0	Triple	16,0	29	27	27	22	32,7	79,5	EBLN1N
NPT 3/4"	3/4"	10,0 - 18,0	Triple	16,0	35	33	33	28	39,0	89,5	EBLN2N
NPT 1"	1"	14,0 - 24,0	Triple	20,0	45	42	42	35	50,0	104,0	EBLN3N
NPT 1 1/4"	1 1/4"	22,0 - 32,0	Triple	20,0	54	51	51	45	60,0	122,0	EBLN4N
NPT 1 1/2"	1 1/2"	26,0 - 35,0	Triple	20,0	63	60	60	55	69,3	137,0	EBLN5N

1 Function Ex d/e Flexible Conduit Straight Fittings

E-CORVUS



Technical Details	
Material	Body, Cap Brass, Brass Nickel Plated, Stainless Steel 316L Seal CR (Chloroprene), Silicone O-ring CR (Chloroprene), Silicone
Ingress Protection Rating	IP 68 - 5 Bar, 30 min IP 66
Operating Temperature	Seal Material CR (Chloroprene) -40°C to +80°C Silicone -60°C to +80°C
Equipment For	Gas & Dust potentially explosive atmospheres
Suitable for use in	Group II Gas Group IIC ZONE1/ZONE2 Group III Dust Group IIIC ZONE21/ZONE 22
Equipment Marking	Ex II 2GD Ex db IIC Gb Ex eb IIC Gb Ex tb IIIC Db
Marking Example *	BMD EBMC.. CE 0722 II 2GD Ex db IIC Gb Ex eb IIC Gb Ex tb IIIC Db Ta-40°C to +80°C IP66/68 CESI 13 ATEX 018X IECEx CES 13.0006X
Thread Type	• Metric (M) ISO Pitch 1.5 • NPT (N) ANSI ASME B1.20.1 • Other thread types also available upon request.
Cable Type	Non Armoured
Accessories	• Lock nuts • Gaskets (Washers) • Serrated Washers • Earth tags
Remarks	• Accessories must be ordered separately. • O-ring available in Metric outer threads.
Approvals	Certificate Number Standards
	IMQ 13 ATEX 018X EN 60079-0:2012+A11:2013 EN 60079-7:2015 EN 60079-31:2014 EN 60079-1:2014
	IECEx IMQ 13.0006X IEC 60079-0:2011 Edition:6 IEC 60079-7:2015 Edition:5 IEC 60079-31:2013 Edition:2 IEC 60079-1:2014 Edition:7
	№ TC RU C-TR.AA87.B.00941 GOCT 31610.0-2014 GOCT IEC 60079-1:2013 GOCT IEC 60079-31:2013
	DNV 12.0052 X ABNT NBR IEC 60079-0:2013 ABNT NBR IEC 60079-1:2009 ABNT NBR IEC 60079-7:2008 ABNT NBR IEC 60079-31:2011
	E-14044 IEC/EN60079-0 IEC/EN60079-7 IEC/EN60079-31 IEC/EN60079-1 IEC/EN 62444

-For more information see our webpage.

* The standard marking consists ATEX & IECEx only. Marking acc. to other standards on request.



Order Coding							
Part Number	Material	Seal	- Gasket (Washer)	Serrated Washer	Lock Nut	Earth Tag	for Ex e
See table	Mandatory	Mandatory	- Option	Option	Option	Option	Option
	B Brass BN Brass Nickel plated X Stainless steel 316L	C Chloroprene S Silicone	- WC Chloroprene WS Silicone WF Fiber	WSR Serrated washer	L Lock nut	E Earth tag	TL9
Example							
EBMC1M	BN	S	- WF	WSR	L	E	TL9

E-CORVUS

1 Function Ex d/e

Flexible Conduit Straight Fittings

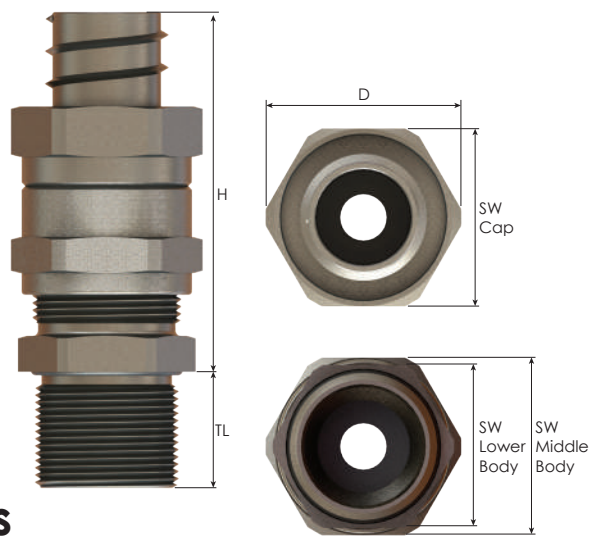

Thread Type **METRIC** acc. to ISO 965-3

Outer Thread Size (Male)	For Seal/Title Nominal Size	Clamping Range		Outer Thread Length		Cap	Spanner Width		Outer Ø	max. Height	Part Number
		Ø min-max mm	Seal Type	Ex-e min.	Ex-d/e min.		Middle Body	Lower Body			
				TL mm		SW Cap mm	SW Middle Body mm	SW Lower Body mm	D mm	H mm	
M12x1,5	1/2"	4,0 - 8,0	Triple	9,0	16,0	24	24	22	26,5	43,0	*EBMC0SM
M16x1,5	3/8"	3,0 - 9,0	Double	9,0	16,0	20	20	20	22,0	39,0	EBMC01SM
	1/2"	4,0 - 12,0	Triple	9,0	16,0	24	24	22	26,5	43,0	EBMC01M
M20x1,5	3/8"	3,0 - 9,0	Double	9,0	16,0	20	20	22	24,5	39,0	EBMC1SM
	1/2"	4,0 - 12,0	Triple	9,0	16,0	24	24	22	26,5	39,0	EBMC1M
	3/4"	10,0 - 16,0	Triple	9,0	16,0	29	29	28	31,5	41,5	EBMC12M
M25x1,5	3/4"	10,0 - 18,0	Triple	9,0	16,0	29	29	28	31,5	42,0	EBMC2M
	1"	14,0 - 20,0	Triple	9,0	16,0	36	36	35	39,8	47,0	EBMC23M
M32x1,5	1"	14,0 - 24,0	Triple	9,0	16,0	36	36	35	39,8	46,0	EBMC3M
	1 1/4"	22,0 - 28,0	Triple	9,0	16,0	45	45	45	50,0	54,0	EBMC34M
M40x1,5	1 1/4"	22,0 - 32,0	Triple	9,0	18,0	45	45	45	50,0	54,0	EBMC4M
	1 1/2"	26,0 - 34,0	Triple	9,0	18,0	52	52	50	59,0	59,5	EBMC45M
M50x1,5	1 1/2"	26,0 - 35,0	Triple	9,0	18,0	52	52	55	61,0	59,5	EBMC5M
	2"	35,0 - 44,0	Triple	9,0	18,0	65	65	64	72,0	58,5	EBMC56M
M63x1,5	2"	35,0 - 45,0	Triple	9,0	18,0	65	65	68	75,0	58,5	EBMC6M
M75x1,5	2 1/2"	46,0 - 59,0	Triple	9,0	20,0	80	80	80	89,0	69,0	EBMC7M

Thread Type **NPT** acc. to ANSI ASME B1.20.1

Outer Thread Size (Male)	For Seal/Title Nominal Size	Clamping Range		Outer Thread Length		Cap	Spanner Width		Outer Ø	max. Height	Part Number
		Ø min-max mm	Seal Type	TL mm			Middle Body	Lower Body			
				TL mm		SW Cap mm	SW Middle Body mm	SW Lower Body mm	D mm	H mm	
NPT 1/4"	1/2"	4,0 - 8,0	Triple	16,0		24	24	22	26,5	43,0	*EBMC0SN
NPT 3/8"	3/8"	3,0 - 9,0	Double	16,0		20	20	20	22,0	39,0	EBMC01SN
	1/2"	4,0 - 12,0	Triple	16,0		24	24	22	26,5	43,0	EBMC01N
NPT 1/2"	3/8"	3,0 - 9,0	Double	16,0		20	20	22	24,5	39,0	EBMC1SN
	1/2"	4,0 - 12,0	Triple	16,0		24	24	22	26,5	39,0	EBMC1N
	3/4"	10,0 - 16,0	Triple	16,0		29	29	28	31,5	41,5	EBMC12N
NPT 3/4"	3/4"	10,0 - 18,0	Triple	16,0		29	29	28	31,5	41,5	EBMC2N
	1"	14,0 - 20,0	Triple	16,0		36	36	35	39,8	46,0	EBMC23N
NPT 1"	1"	14,0 - 24,0	Triple	20,0		36	36	35	39,8	46,0	EBMC3N
	1 1/4"	22,0 - 26,0	Triple	20,0		45	45	45	50,0	53,5	EBMC34N
NPT 1 1/4"	1 1/4"	22,0 - 32,0	Triple	20,0		45	45	45	50,0	54,0	EBMC4N
	1 1/2"	26,0 - 34,0	Triple	20,0		52	52	50	59,0	59,5	EBMC45N
NPT 1 1/2"	1 1/2"	26,0 - 35,0	Triple	20,0		52	52	55	61,0	59,5	EBMC5N
	2"	35,0 - 41,0	Triple	20,0		65	65	64	72,0	56,5	EBMC56N
NPT 2"	2"	35,0 - 45,0	Triple	20,0		65	65	68	75,0	58,5	EBMC6N
NPT 2 1/2"	2 1/2"	46,0 - 59,0	Triple	21,0		80	80	80	89,0	69,0	EBMC7N

ADAPTORS and PLUGS for Gas & Dust Applications



Apus, Enlargers

Grus, Reducers

Aries, Couplings

Pavo, Nipples

Aquila Hexagonal, Plugs

Aquila Round, Plugs

230 - 233

234 - 237

238 - 241

242 - 245

246 - 247

248 - 249

Ex Glands / Group II-III / Gas & Dust



Adaptors are used where the thread size of the cable gland or connection device is larger than, or of an equivalent size, to the entry thread of the enclosure. Reducers are used where the thread size of the cable gland or entry device is smaller than the entry thread of the enclosure. A coupling is a very short length of pipe or tube, with a socket at one or both ends that allows two pipes or tubes to be joined. Alternatively it is a short length of pipe with two female National pipe threads (NPT) (in North American terms, a coupler is a double female while a nipple is double male) or two male or female British standard pipe threads. When the two ends use the same connection method but are of a different size, the terms reducing coupling or reducer are used.

Enlargers for Ex d/e Applications

Technical Details		
Material	Body Brass, Brass Nickel Plated, Stainless Steel 316L O-ring CR (Chloroprene), Silicone	
Ingress Protection Rating	IP 68 - 5 Bar, 30 min IP 66	
Operating Temperature	O-ring Material CR (Chloroprene) -40°C to +100°C Silicone -60°C to +130°C	
Equipment For	• Gas & Dust potentially explosive atmospheres.	
Suitable for use in	Group II Gas Group IIC ZONE1/ZONE2 Group III Dust Group IIIC ZONE21/ZONE 22	
Equipment Marking	Ex II 2GD Ex db IIC Gb Ex eb IIC Gb Ex tb IIIC Db	
Marking Example *	BMD B-RB.. CE 0722  II 2GD Ex db IIC Gb Ex eb IIC Gb Ex tb IIIC Db Ta-40°C to +100°C IP66/68 CESI 13 ATEX 066X IECEx CES 13.0022X	
Thread Type	• Metric (M) ISO Pitch 1,5 • Npt (N) ANSI ASME B1.20.1 • PG (P) DIN 40430 • (G) GAS UNI ISO 228/1	
Accessories	• Gaskets (Washers)	
Remarks	• Accessories must be ordered separately. • O-ring only available when male thread is Metric.	
Approvals	Certificate Number	Standards
	CESI 13 ATEX 066X	EN 60079-0:2012+A11:2013 EN 60079-1:2014 EN 60079-7:2015 EN 60079-31:2014
	IECEx CES 13.0022X	IEC 60079-0:2011 Edition:6 IEC 60079-1:2014 Edition:7 IEC 60079-31:2013 Edition:2 IEC 60079-7:2015 Edition:5
	№ TC RU C-TR.AA87.B.00941	ГОСТ 31610.0-2014 ГОСТ IEC 60079-1:2013 ГОСТ IEC 60079-31:2013
	DNV 12.0150 X	ABNT NBR IEC 60079-0:2008, ABNT NBR IEC 60079-1:2009, ABNT NBR IEC 60079-7:2008, ABNT NBR IEC 60079-31:2011
	E-14044	IEC/EN60079-0, IEC/EN60079-7, IEC/EN60079-31, IEC/EN60079-1 & IEC/EN 62444

- Other sizes available upon request. For more information see our webpage.
* The standard marking consists ATEX & IECEx only. Marking acc. to other standards on request.

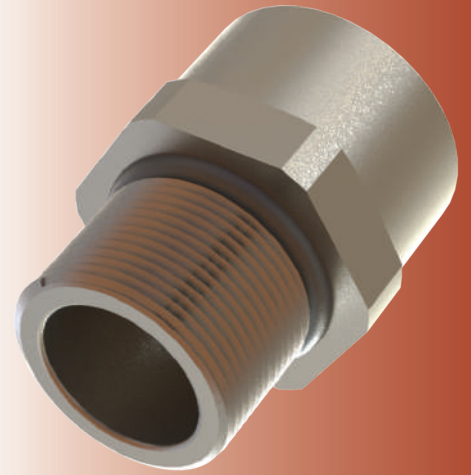

Order Coding			
Part Number	Material	Seal	Gasket (Washer)
Mandatory	Mandatory	Mandatory	- Option
See table	B Brass BN Brass Nickel plated X Stainless steel 316L	C Chloroprene S Silicone	- WC Chloroprene WS Silicone WF Fiber
Example			
B-RB01M01M	BN	C	- WC

APUS Enlargers for Ex d/e Applications

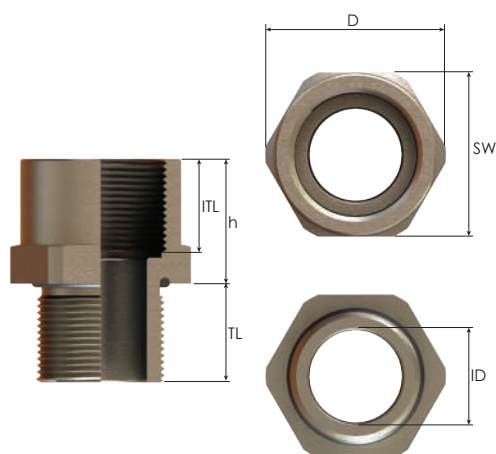

Thread Type METRIC > METRIC acc. to ISO 965-3								
Outer Thread Size (Male)	Inner Thread Size (Female)	Outer Thread Length	Inner Thread Length	Spanner Width	Outer Ø	Inner Ø	Height	Part Number
		TL mm	ITL mm	SW mm	D mm	ID mm	h mm	
M16x1,5	M20x1,5	15,0	15,0	25	27,5	10,0	19,0	B-RB1M01M
	M25x1,5	15,0	15,0	30	33,0	10,0	19,0	B-RB2M01M
	M32x1,5	15,0	15,0	36	39,5	10,0	19,0	B-RB3M01M
M20x1,5	M25x1,5	15,0	15,0	30	33,0	14,0	19,0	B-RB2M1M
	M32x1,5	15,0	15,0	36	39,5	14,0	19,0	B-RB3M1M
	M40x1,5	15,0	18,0	45	50,0	14,0	22,0	B-RB4M1M
M25x1,5	M32x1,5	15,0	15,0	36	39,5	19,0	19,0	B-RB3M2M
	M40x1,5	15,0	18,0	45	50,0	19,0	22,0	B-RB4M2M
	M50x1,5	15,0	18,0	55	61,0	19,0	22,0	B-RB5M2M
M32x1,5	M40x1,5	15,0	18,0	45	50,0	26,0	22,0	B-RB4M3M
	M50x1,5	15,0	18,0	55	61,0	26,0	22,0	B-RB5M3M
	M60x1,5	18,0	18,0	68	75,0	26,0	22,5	B-RB6M3M
M40x1,5	M50x1,5	18,0	18,0	55	61,0	34,0	22,0	B-RB5M4M
	M60x1,5	18,0	18,0	68	75,0	34,0	22,5	B-RB6M4M
	M63x1,5	18,0	18,0	68	75,0	34,0	22,5	B-RB6M4M
	M70x1,5	18,0	18,0	80	88,5	34,0	22,5	B-RB7M4M
	M75x1,5	18,0	18,0	80	88,5	34,0	22,5	B-RB7M4M
M50x1,5	M60x1,5	18,0	18,0	68	75,0	44,0	22,5	B-RB6M5M
	M63x1,5	18,0	18,0	68	75,0	44,0	22,5	B-RB6M5M
	M70x1,5	18,0	18,0	80	88,5	44,0	22,5	B-RB7M5M
	M75x1,5	18,0	18,0	80	88,5	44,0	22,5	B-RB7M5M
	M80x1,5	18,0	18,0	90	100,0	44,0	22,5	B-RB8M5M
M60x1,5	M63x1,5	18,0	18,0	68	75,0	54,0	22,5	B-RB6M6M
	M70x1,5	18,0	18,0	80	88,5	54,0	22,5	B-RB7M6M
	M75x1,5	18,0	18,0	80	88,5	54,0	22,5	B-RB7M6M
	M80x1,5	18,0	18,0	90	100,0	54,0	22,5	B-RB8M6M
	M85x1,5	18,0	18,0	95	105,0	54,0	22,5	B-RB8M6M
M63x1,5	M90x1,5	18,0	21,0	95	105,0	54,0	25,5	B-RB8M6M
	M70x1,5	18,0	18,0	80	88,5	57,0	22,5	B-RB7M6M
	M75x1,5	18,0	18,0	80	88,5	57,0	22,5	B-RB7M6M
	M80x1,5	18,0	18,0	90	100,0	57,0	22,5	B-RB8M6M
	M85x1,5	18,0	18,0	95	105,0	57,0	22,5	B-RB8M6M
M70x1,5	M90x1,5	18,0	21,0	95	105,0	57,0	25,5	B-RB8M6M
	M75x1,5	18,0	18,0	80	88,5	64,0	22,5	B-RB7M7M
	M80x1,5	18,0	18,0	90	100,0	64,0	22,5	B-RB8M7M
	M85x1,5	18,0	18,0	95	105,0	64,0	22,5	B-RB8M7M
	M90x1,5	18,0	21,0	95	105,0	64,0	25,5	B-RB8M7M
M75x1,5	M80x1,5	18,0	18,0	90	100,0	69,0	22,5	B-RB8M7M
	M85x1,5	18,0	18,0	95	105,0	69,0	22,5	B-RB8M7M
	M90x1,5	18,0	21,0	95	105,0	69,0	25,5	B-RB8M7M
	M100x1,5	18,0	21,0	110	123,0	69,0	25,5	B-RB9M7M
M80x1,5	M85x1,5	18,0	18,0	95	105,0	72,0	22,5	B-RB8M8M
	M90x1,5	18,0	21,0	95	105,0	72,0	25,5	B-RB8M8M
	M100x1,5	18,0	21,0	110	123,0	72,0	25,5	B-RB9M8M
	M110x1,5	18,0	21,0	120	134,0	72,0	26,0	B-RB10M8M
M85x1,5	M90x1,5	18,0	21,0	95	105,0	77,0	25,5	B-RB8M8M
	M100x1,5	18,0	21,0	110	123,0	77,0	25,5	B-RB9M8M
	M110x1,5	18,0	21,0	120	134,0	77,0	26,0	B-RB10M8M
M90x1,5	M100x1,5	21,0	21,0	110	123,0	84,0	26,0	B-RB9M8M
	M110x1,5	21,0	21,0	120	134,0	84,0	26,0	B-RB10M8M
M100x1,5	M110x1,5	21,0	21,0	120	134,0	94,0	26,0	B-RB10M9M

APUS Enlargers for Ex d/e Applications

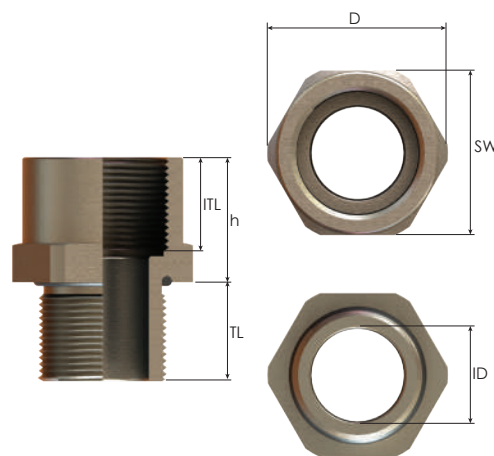

Thread Type NPT acc. to ANSI ASME B1.20.1 > METRIC acc. to ISO 965-3								
Outer Thread Size (Male)	Inner Thread Size (Female)	Outer Thread Length	Inner Thread Length	Spanner Width	Outer Ø	Inner Ø	Height	Part Number
		TL mm	ITL mm	SW mm	D mm	ID mm	h mm	
NPT 3/8"	M16x1,5	15,0	15,0	22	24,0	12,0	18,5	B-RB01M01N
	M20x1,5	15,0	15,0	25	27,5	12,0	19,0	B-RB1M01N
	M25x1,5	15,0	15,0	30	33,0	14,5	19,0	B-RB2M01N
	M32x1,5	15,0	15,0	36	39,5	12,0	19,0	B-RB3M01N
NPT 1/2"	M20x1,5	15,0	15,0	25	27,5	14,5	19,0	B-RB1M1N
	M25x1,5	15,0	15,0	30	33,0	14,5	19,0	B-RB2M1N
	M32x1,5	15,0	15,0	36	39,5	14,5	19,0	B-RB3M1N
	M40x1,5	15,0	18,0	45	50,0	14,5	22,0	B-RB4M1N
NPT 3/4"	M20x1,5	15,0	15,0	30	33,0	14,5	19,0	B-RB1M2N
	M32x1,5	15,0	15,0	36	39,5	19,0	19,0	B-RB3M2N
	M40x1,5	15,0	18,0	45	50,0	19,0	22,0	B-RB4M2N
	M50x1,5	18,0	18,0	55	61,0	19,0	22,0	B-RB5M2N
NPT 1"	M32x1,5	15,0	15,0	36,0	39,5	26,0	19,0	B-RB3M3N
	M40x1,5	15,0	18,0	45,0	50,0	26,0	22,0	B-RB4M3N
	M50x1,5	18,0	18,0	55,0	61,0	26,0	22,0	B-RB5M3N
	M60x1,5	18,0	18,0	68,0	75,0	26,0	22,5	B-RB6M3N
NPT 1 1/4"	M63x1,5	18,0	18,0	68,0	75,0	26,0	22,5	B-RB6M3N
	M40x1,5	18,0	18,0	45,0	50,0	35,0	22,0	B-RB4M4N
	M50x1,5	18,0	18,0	55,0	61,0	35,0	22,0	B-RB5M4N
	M60x1,5	18,0	18,0	68,0	75,0	35,0	22,5	B-RB6M4N
	M63x1,5	18,0	18,0	68,0	75,0	35,0	22,5	B-RB6M4N
NPT 1 1/2"	M70x1,5	18,0	18,0	80,0	88,5	35,0	22,5	B-RB7M4N
	M75x1,5	18,0	18,0	80,0	88,5	35,0	22,5	B-RB7M4N
	M50x1,5	18,0	18,0	55,0	61,0	40,0	22,0	B-RB5M5N
	M60x1,5	18,0	18,0	68,0	75,0	40,0	22,5	B-RB6M5N
	M63x1,5	18,0	18,0	68,0	75,0	40,0	22,5	B-RB6M5N
NPT 2"	M70x1,5	18,0	18,0	80,0	88,5	40,0	22,5	B-RB7M5N
	M75x1,5	18,0	18,0	80,0	88,5	40,0	22,5	B-RB7M5N
	M80x1,5	18,0	18,0	90,0	100,0	51,0	23,0	B-RB8M6N
	M85x1,5	18,0	18,0	95,0	105,0	51,0	23,0	B-RB8M6N
	M90x1,5	28,0	21,0	95,0	105,0	51,0	26,0	B-RB8M6N
NPT 2 1/2"	M75x1,5	28,0	18,0	80,0	88,5	62,0	22,5	B-RB7M7N
	M80x1,5	28,0	18,0	90,0	100,0	62,0	23,0	B-RB8M7N
	M85x1,5	28,0	18,0	95,0	105,0	62,0	23,0	B-RB8M7N
	M90x1,5	28,0	21,0	95,0	105,0	62,0	26,0	B-RB8M7N
NPT 3"	M85x1,5	28,0	18,0	95,0	105,0	75,0	23,0	B-RB8M8N
	M90x1,5	28,0	21,0	95,0	105,0	75,0	26,0	B-RB8M8N
	M100x1,5	28,0	21,0	110,0	123,0	75,0	26,0	B-RB9M8N
	M110x1,5	28,0	21,0	120,0	134,0	75,0	26,0	B-RB10M8N
NPT 3 1/2"	M100x1,5	28,0	21,0	110,0	123,0	87,0	26,0	B-RB9M9N
	M110x1,5	28,0	21,0	120,0	134,0	87,0	26,0	B-RB10M9N
NPT 4"	M110x1,5	28,0	21,0	120,0	134,0	100,0	26,0	B-RB10M10N

APUS Enlargers for Ex d/e Applications







Thread Type **NPT > NPT** acc. to ANSI ASME B1.20.1

Outer Thread Size (Male)	Inner Thread Size (Female)	Outer Thread Length	Inner Thread Length	Spanner Width	Outer Ø	Inner Ø	Height	Part Number
		TL mm	ITL mm	SW mm	D mm	ID mm	h mm	
NPT 3/8"	NPT 1/2"	15,0	15,0	25	27,5	13,0	19,0	B-RB1N01N
	NPT 3/4"	15,0	15,0	30	33,0	12,0	19,0	B-RB2N01N
	NPT 1"	15,0	15,0	30	39,5	12,0	19,0	B-RB3N01N
NPT 1/2"	NPT 3/4"	15,0	15,0	30	33,0	14,5	19,0	B-RB2N1N
	NPT 1"	15,0	15,0	36	39,5	14,5	19,0	B-RB3N1N
	NPT 1 1/4"	15,0	18,0	45	50,0	14,5	22,0	B-RB4N1N
NPT 3/4"	NPT 1"	15,0	15,0	36	39,5	20,0	19,0	B-RB3N2N
	NPT 1 1/4"	15,0	18,0	45	50,0	20,0	22,0	B-RB4N2N
	NPT 1 1/2"	15,0	18,0	55	61,0	20,0	22,5	B-RB5N2N
NPT 1"	NPT 1 1/4"	15,0	18,0	45	50,0	27,0	22,0	B-RB4N3N
	NPT 1 1/2"	15,0	18,0	55	61,0	25,0	22,5	B-RB5N3N
	NPT 2"	18,0	18,0	65	72,0	25,0	22,5	B-RB6N3N
NPT 1 1/4"	NPT 1 1/2"	18,0	18,0	55	61,0	40,5	22,5	B-RB5N4N
	NPT 2"	18,0	18,0	65	72,0	40,5	22,5	B-RB6N4N
	NPT 2 1/2"	18,0	28,0	80	88,5	35,0	32,5	B-RB7N4N
NPT 1 1/2"	NPT 2"	18,0	18,0	65	72,0	41,0	22,5	B-RB6N5N
	NPT 2 1/2"	18,0	28,0	80	88,5	41,0	32,5	B-RB7N5N
	NPT 3"	28,0	28,0	95	105,0	41,0	32,5	B-RB8N5N
NPT 2"	NPT 2 1/2"	18,0	28,0	80	88,5	53,0	32,5	B-RB7N6N
	NPT 3"	28,0	28,0	95	105,0	53,0	32,5	B-RB8N6N
	NPT 3 1/2"	28,0	28,0	110	123,0	53,0	33,0	B-RB9N6N
NPT 2 1/2"	NPT 3"	28,0	28,0	95	105,0	62,0	32,5	B-RB8N7N
	NPT 3 1/2"	28,0	28,0	110	123,0	62,0	33,0	B-RB9N7N
	NPT 4"	28,0	28,0	120	134,0	62,0	33,0	B-RB10N7N
NPT 3"	NPT 3 1/2"	28,0	28,0	110	123,0	75,0	33,0	B-RB9N8N
	NPT 4"	28,0	28,0	120	134,0	75,0	33,0	B-RB10N8N
	NPT 3 1/2"	28,0	28,0	120	134,0	87,5	33,0	B-RB10N9N

Thread Type **METRIC** acc. to ISO 965-3 > **NPT** acc. to ANSI ASME B1.20.1

Outer Thread Size (Male)	Inner Thread Size (Female)	Outer Thread Length	Inner Thread Length	Spanner Width	Outer Ø	Inner Ø	Height	Part Number
		TL mm	ITL mm	SW mm	D mm	ID mm	h mm	
M16x1,5	NPT 3/8"	15,0	15,0	20	22,0	10,0	18,5	B-RB01N01M
	NPT 1/2"	15,0	15,0	25	27,5	10,0	19,0	B-RB1N01M
	NPT 3/4"	15,0	15,0	30	33,0	10,0	19,0	B-RB2N01M
M20x1,5	NPT 3/4"	15,0	15,0	30	33,0	14,0	19,0	B-RB2N1M
	NPT 1"	15,0	15,0	36	39,5	14,0	19,0	B-RB3N1M
	NPT 1 1/4"	15,0	18,0	45	50,0	14,0	22,0	B-RB4N1M
M25x1,5	NPT 3/4"	15,0	15,0	30	33,0	19,0	19,0	B-RB2N2M
	NPT 1"	15,0	15,0	36	39,5	19,0	19,0	B-RB3N2M
	NPT 1 1/4"	15,0	18,0	45	50,0	19,0	22,0	B-RB4N2M
M32x1,5	NPT 1"	15,0	15,0	36	39,5	26,0	19,0	B-RB3N3M
	NPT 1 1/4"	15,0	18,0	45	50,0	26,0	22,0	B-RB4N3M
	NPT 1 1/2"	18,0	18,0	55	61,0	26,0	22,0	B-RB5N3M
M40x1,5	NPT 1 1/4"	18,0	18,0	45	50,0	34,0	22,0	B-RB4N4M
	NPT 1 1/2"	18,0	18,0	55	61,0	34,0	22,0	B-RB5N4M
	NPT 2"	18,0	18,0	65	72,0	34,0	22,5	B-RB6N4M
M50x1,5	NPT 1 1/2"	18,0	18,0	55	61,0	40,0	22,0	B-RB5N5M
	NPT 2"	18,0	18,0	65	72,0	44,0	22,5	B-RB6N5M
	NPT 2 1/2"	18,0	28,0	80	88,5	44,0	32,5	B-RB7N5M
M60x1,5	NPT 2"	18,0	18,0	68	75,0	48,0	22,5	B-RB6N6M
	NPT 2 1/2"	18,0	28,0	80	88,5	54,0	32,5	B-RB7N6M
	NPT 3"	18,0	28,0	95	105,0	54,0	32,5	B-RB8N6M
M63x1,5	NPT 2"	18,0	18,0	68	75,0	51,0	22,5	B-RB6N6M
	NPT 2 1/2"	18,0	28,0	80	88,5	57,0	32,5	B-RB7N6M
	NPT 3"	18,0	28,0	95	105,0	51,0	32,5	B-RB8N6M
M70x1,5	NPT 2 1/2"	18,0	28,0	80	88,5	64,0	32,5	B-RB7N7M
	NPT 3"	18,0	28,0	95	105,0	64,0	32,5	B-RB8N7M
	NPT 3 1/2"	18,0	28,0	110	123,0	64,0	33,0	B-RB9N7M
M75x1,5	NPT 2 1/2"	18,0	28,0	80	88,5	69,0	32,5	B-RB7N7M
	NPT 3"	18,0	28,0	95	105,0	69,0	32,5	B-RB8N7M
	NPT 3 1/2"	18,0	28,0	110	123,0	69,0	33,0	B-RB9N7M
M80x1,5	NPT 3"	18,0	28,0	95	105,0	72,0	32,5	B-RB8N8M
	NPT 3 1/2"	18,0	28,0	110	123,0	72,0	33,0	B-RB9N8M
	NPT 4"	18,0	28,0	120	134,0	72,0	33,0	B-RB10N8M
M85x1,5	NPT 3"	18,0	28,0	95	105,0	77,0	32,5	B-RB8N8M
	NPT 3 1/2"	18,0	28,0	110	123,0	77,0	33,0	B-RB9N8M
	NPT 4"	18,0	28,0	120	134,0	77,0	33,0	B-RB10N8M
M90x1,5	NPT 3"	21,0	28,0	95	105,0	78,0	33,0	B-RB8N8M
	NPT 3 1/2"	21,0	28,0	110	123,0	78,0	33,0	B-RB9N8M
	NPT 4"	21,0	28,0	120	134,0	78,0	33,0	B-RB10N8M
M100x1,5	NPT 3 1/2"	21,0	28,0	110	123,0	94,0	33,0	B-RB9N9M
	NPT 4"	21,0	28,0	120	134,0	94,0	33,0	B-RB10N9M
M110x1,5	NPT 4"	21,0	28,0	120	134,0	103,0	33,0	B-RB10N10M

Reducers for Ex d/e Applications

Technical Details		
Material	Body	Brass, Brass Nickel Plated, Stainless Steel 316L
	O-Ring	CR (Chloroprene), Silicone
Ingress Protection Rating	IP 68 - 5 Bar, 30 min IP 66	
Operating Temperature	O-ring Material	
	CR (Chloroprene)	Silicone
Ex d/e/tb	-40°C to +100°C -60°C to +130°C	
Equipment For	• Gas & Dust potentially explosive atmospheres.	
Suitable for use in	Group II	Gas Group IIC ZONE1/ZONE2
	Group III	Dust Group IIIC ZONE21/ZONE 22
Equipment Marking	Ex II 2GD Ex db IIC Gb Ex eb IIC Gb Ex tb IIIC Db	
Marking Example *	BMD B-RA.. CE 0722  II 2GD Ex db IIC Gb Ex eb IIC Gb Ex tb IIIC Db Tq-40°C to +100°C IP66/68 CESI 13 ATEX 066X IECEx CES 13.0022X	
Thread Type	• Metric (M) ISO Pitch 1,5 • Npt (N) ANSI ASME B1.20.1 • PG (P) DIN 40430 • (G) GAS UNI ISO 228/1	
Accessories	• Gaskets (Washers)	
Remarks	• Accessories must be ordered separately. • O-ring available in Metric.	
Approvals	Certificate Number	Standards
	CESI 13 ATEX 066X	EN 60079-0:2012+A11:2013 EN 60079-1:2014 EN 60079-7:2015 EN 60079-31:2014
	IECEx CES 13.0022X	IEC 60079-0:2011 Edition:6 IEC 60079-1:2014 Edition:7 IEC 60079-31:2013 Edition:2 IEC 60079-7:2015 Edition:5
	№ TC RU C-TR.AA87.B.00941	ГОСТ 31610.0-2014 ГОСТ IEC 60079-1:2013 ГОСТ IEC 60079-31:2013
	DNV 12.0150 X	ABNT NBR IEC 60079-0:2008, ABNT NBR IEC 60079-1:2009, ABNT NBR IEC 60079-7:2008, ABNT NBR IEC 60079-31:2011
	E-14044	IEC/EN60079-0, IEC/EN60079-7, IEC/EN60079-31, IEC/EN60079-1 & IEC/EN 62444

- Other sizes available upon request. For more information see our webpage.
* The standard marking consists ATEX & IECEx only. Marking acc. to other standards on request.

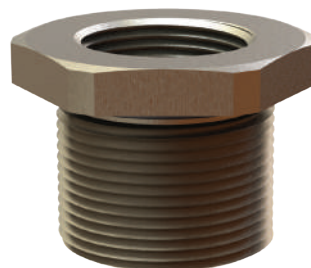
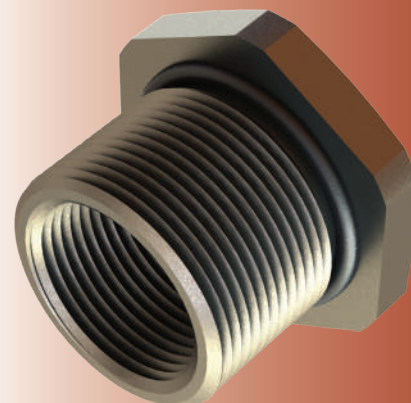

Order Coding			
Part Number	Material	Seal	Gasket (Washer)
	Mandatory	Mandatory	- Option
See table	B Brass BN Brass Nickel plated X Stainless steel 316L	C Chloroprene S Silicone	- WC Chloroprene WS Silicone WF Fiber
Example			
B-RA2M01M	BN	C	- WS

GRUS

Reducers for Ex d/e Applications

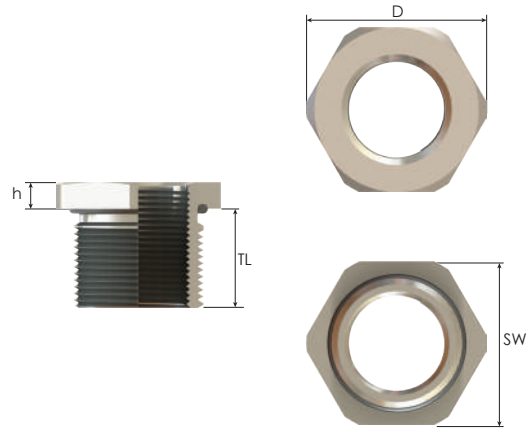

Thread Type METRIC > METRIC acc. to ISO965-3						
Outer Thread Size (Male)	Inner Thread Size (Female)	Outer Thread Length	Spanner Width	Outer Ø	Height	Part Number
		TL mm	SW mm	D mm	h mm	
M20x1,5	M16x1,5	15,0	25	27,5	4,0	B-RA1M01M
M25x1,5	M16x1,5	15,0	30	33,0	4,0	B-RA2M01M
	M20x1,5	15,0	30	33,0	4,0	B-RA2M1M
M32x1,5	M16x1,5	15,0	36	39,5	4,0	B-RA3M01M
	M20x1,5	15,0	36	39,5	4,0	B-RA3M1M
	M25x1,5	15,0	36	39,5	4,0	B-RA3M2M
M40x1,5	M16x1,5	18,0	45	50,0	4,0	B-RA4M01M
	M20x1,5	18,0	45	50,0	4,0	B-RA4M1M
	M25x1,5	18,0	45	50,0	4,0	B-RA4M2M
	M32x1,5	18,0	45	50,0	4,0	B-RA4M3M
M50x1,5	M16x1,5	18,0	55	61,0	5,0	B-RA5M01M
	M20x1,5	18,0	55	61,0	5,0	B-RA5M1M
	M25x1,5	18,0	55	61,0	5,0	B-RA5M2M
	M32x1,5	18,0	55	61,0	5,0	B-RA5M3M
	M40x1,5	18,0	55	61,0	5,0	B-RA5M4M
M60x1,5	M20x1,5	18,0	70	77,0	5,0	B-RA6M1M
	M25x1,5	18,0	70	77,0	5,0	B-RA6M2M
	M32x1,5	18,0	70	77,0	5,0	B-RA6M3M
	M40x1,5	18,0	70	77,0	5,0	B-RA6M4M
	M50x1,5	18,0	70	77,0	5,0	B-RA6M5M
M63x1,5	M20x1,5	18,0	70	77,0	5,0	B-RA6M1M
	M25x1,5	18,0	70	77,0	5,0	B-RA6M2M
	M32x1,5	18,0	70	77,0	5,0	B-RA6M3M
	M40x1,5	18,0	70	77,0	5,0	B-RA6M4M
	M50x1,5	18,0	70	77,0	5,0	B-RA6M5M
M70x1,5	M25x1,5	18,0	80	89,0	6,0	B-RA7M2M
	M32x1,5	18,0	80	89,0	6,0	B-RA7M3M
	M40x1,5	18,0	80	89,0	6,0	B-RA7M4M
	M50x1,5	18,0	80	89,0	6,0	B-RA7M5M
	M60x1,5	18,0	80	89,0	6,0	B-RA7M60M
M75x1,5	M32x1,5	18,0	85	94,0	6,0	B-RA7M3M
	M40x1,5	18,0	85	94,0	6,0	B-RA7M4M
	M50x1,5	18,0	85	94,0	6,0	B-RA7M5M
	M60x1,5	18,0	85	94,0	6,0	B-RA7M60M
	M63x1,5	18,0	85	94,0	6,0	B-RA7M6M
M80x1,5	M40x1,5	18,0	90	100,0	6,0	B-RA8M4M
	M50x1,5	18,0	90	100,0	6,0	B-RA8M5M
	M60x1,5	18,0	90	100,0	6,0	B-RA8M60M
	M63x1,5	18,0	90	100,0	6,0	B-RA8M6M
	M70x1,5	18,0	90	100,0	6,0	B-RA8M70M
M85x1,5	M50x1,5	21,0	95	105,0	8,0	B-RA85M5M
	M60x1,5	21,0	95	105,0	8,0	B-RA85M60M
	M63x1,5	21,0	95	105,0	8,0	B-RA85M6M
	M70x1,5	21,0	95	105,0	8,0	B-RA85M70M
	M75x1,5	21,0	95	105,0	8,0	B-RA85M7M
M90x1,5	M63x1,5	21,0	100	111,0	8,0	B-RA8M6M
	M70x1,5	21,0	100	111,0	8,0	B-RA8M70M
	M75x1,5	21,0	100	111,0	8,0	B-RA8M7M
	M80x1,5	21,0	100	111,0	8,0	B-RA8M80M
M100x1,5	M80x1,5	21,0	110	123,0	10,0	B-RA9M80M
	M85x1,5	21,0	110	123,0	10,0	B-RA9M85M
	M90x1,5	21,0	110	123,0	10,0	B-RA9M8M
M110x1,5	M90x1,5	21,0	120	133,5	10,0	B-RA10M8M
	M100x1,5	21,0	120	133,5	10,0	B-RA10M9M

GRUS Reducers for Ex d/e Applications

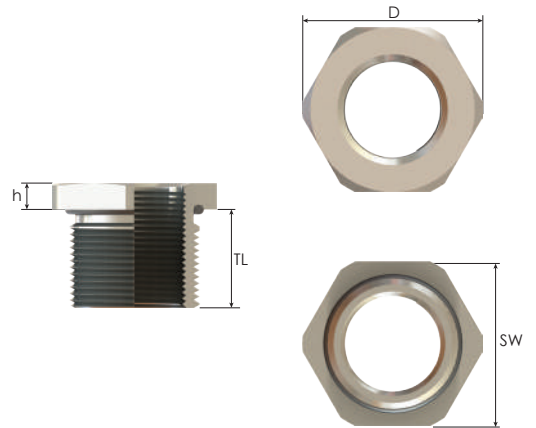

Thread Type **METRIC** acc. to ISO 965-3 > **NPT** acc. to ANSI ASME B1.20.1

Outer Thread Size (Male)	Inner Thread Size (Female)	Outer Thread Length	Spanner Width	Outer Ø	Height	Part Number
		TL mm	SW mm	D mm	h mm	
M20x1,5	NPT 3/8"	15,0	25	27,5	4,0	B-RA1M01N
	NPT 3/8"	15,0	30	33,0	4,0	B-RA2M01N
M25x1,5	NPT 1/2"	15,0	30	33,0	4,0	B-RA2M1N
	NPT 3/8"	15,0	36	39,5	4,0	B-RA3M01N
M32x1,5	NPT 1/2"	15,0	36	39,5	4,0	B-RA3M1N
	NPT 3/4"	15,0	36	39,5	4,0	B-RA3M2N
	NPT 3/8"	18,0	45	50,0	4,0	B-RA4M01N
M40x1,5	NPT 1/2"	18,0	45	50,0	4,0	B-RA4M1N
	NPT 3/4"	18,0	45	50,0	4,0	B-RA4M2N
	NPT 3/8"	18,0	55	61,0	5,0	B-RA5M01N
M50x1,5	NPT 1/2"	18,0	55	61,0	5,0	B-RA5M1N
	NPT 3/4"	18,0	55	61,0	5,0	B-RA5M2N
	NPT 3/8"	18,0	70	77,0	5,0	B-RA6M0M1N
M60x1,5	NPT 1/2"	18,0	70	77,0	5,0	B-RA6M0M1N
	NPT 3/4"	18,0	70	77,0	5,0	B-RA6M0M2N
	NPT 1"	18,0	70	77,0	5,0	B-RA6M0M3N
	NPT 3/8"	18,0	70	77,0	5,0	B-RA6M01N
M63x1,5	NPT 1/2"	18,0	70	77,0	5,0	B-RA6M1N
	NPT 3/4"	18,0	70	77,0	5,0	B-RA6M2N
	NPT 1"	18,0	70	77,0	5,0	B-RA6M3N
	NPT 3/8"	18,0	80	89,0	6,0	B-RA7M0M1N
M70x1,5	NPT 1/2"	18,0	80	89,0	6,0	B-RA7M0M1N
	NPT 3/4"	18,0	80	89,0	6,0	B-RA7M0M2N
	NPT 1"	18,0	80	89,0	6,0	B-RA7M0M3N
	NPT 1 1/4"	18,0	80	89,0	6,0	B-RA7M0M4N
	NPT 1/2"	18,0	80	89,0	6,0	B-RA7M1N
M75x1,5	NPT 3/4"	18,0	85	94,0	6,0	B-RA7M2N
	NPT 1"	18,0	85	94,0	6,0	B-RA7M3N
	NPT 1 1/4"	18,0	85	94,0	6,0	B-RA7M4N
	NPT 1 1/2"	18,0	85	94,0	6,0	B-RA7M5N
	NPT 3/4"	18,0	90	100,0	6,0	B-RA8M0M2N
M80x1,5	NPT 1"	18,0	90	100,0	6,0	B-RA8M0M3N
	NPT 1 1/4"	18,0	90	100,0	6,0	B-RA8M0M4N
	NPT 1 1/2"	18,0	90	100,0	6,0	B-RA8M0M5N
	NPT 2"	18,0	90	100,0	6,0	B-RA8M0M6N
	NPT 1"	21,0	95	105,0	8,0	B-RA8M3N
M85x1,5	NPT 1 1/4"	21,0	95	105,0	8,0	B-RA8M4N
	NPT 1 1/2"	21,0	95	105,0	8,0	B-RA8M5N
	NPT 2"	21,0	95	105,0	8,0	B-RA8M6N
	NPT 2 1/2"	21,0	95	105,0	8,0	B-RA8M7N
	NPT 1 1/4"	21,0	100	111,0	8,0	B-RA8M4N
M90x1,5	NPT 1 1/2"	21,0	100	111,0	8,0	B-RA8M5N
	NPT 2"	21,0	100	111,0	8,0	B-RA8M6N
	NPT 2 1/2"	21,0	100	111,0	8,0	B-RA8M7N
	NPT 1 1/2"	21,0	110	123,0	10,0	B-RA9M5N
M100x1,5	NPT 2"	21,0	110	123,0	10,0	B-RA9M6N
	NPT 2 1/2"	21,0	110	123,0	10,0	B-RA9M7N
	NPT 3"	21,0	110	123,0	10,0	B-RA9M8N
M110x1,5	NPT 2"	21,0	120	133,5	10,0	B-RA10M6N
	NPT 2 1/2"	21,0	120	133,5	10,0	B-RA10M7N

GRUS

Reducers for Ex d/e Applications







Thread Type **NPT** > **NPT** acc. to ANSI ASME B1.20.1

Outer Thread Size (Male)	Inner Thread Size (Female)	Outer Thread Length	Spanner Width	Outer Ø	Height	Part Number
		TL mm	SW mm	D mm	h mm	
NPT 1/2"	NPT 3/8"	15,0	25	27,5	4,0	B-RA1N01N
NPT 3/4"	NPT 3/8"	15,0	30	33	4,0	B-RA2N01N
	NPT 1/2"	15,0	30	33	4,0	B-RA2N1N
NPT 1"	NPT 3/8"	15,0	36	39,5	4,0	B-RA3N01N
	NPT 1/2"	15,0	36	39,5	4,0	B-RA3N1N
	NPT 3/4"	15,0	36	39,5	4,0	B-RA3N2N
NPT 1 1/4"	NPT 1/2"	18,0	45	50	4,0	B-RA4N1N
	NPT 3/4"	18,0	45	50	4,0	B-RA4N2N
	NPT 1"	18,0	45	50	4,0	B-RA4N3N
NPT 1 1/2"	NPT 3/4"	18,0	55	61	5,0	B-RA5N2N
	NPT 1"	18,0	55	61	5,0	B-RA5N3N
	NPT 1 1/4"	18,0	55	61	5,0	B-RA5N4N
NPT 2"	NPT 3/4"	18,0	65	72	5,0	B-RA6N2N
	NPT 1"	18,0	65	72	5,0	B-RA6N3N
	NPT 1 1/4"	18,0	65	72	5,0	B-RA6N4N
	NPT 1 1/2"	18,0	65	72	5,0	B-RA6N5N
NPT 2 1/2"	NPT 3/4"	28,0	75	83	6,0	B-RA7N2N
	NPT 1"	28,0	75	83	6,0	B-RA7N3N
	NPT 1 1/4"	28,0	75	83	6,0	B-RA7N4N
	NPT 1 1/2"	28,0	75	83	6,0	B-RA7N5N
	NPT 2"	28,0	75	83	6,0	B-RA7N6N
NPT 3"	NPT 1"	28,0	95	105	8,0	B-RA8N3N
	NPT 1 1/4"	28,0	95	105	8,0	B-RA8N4N
	NPT 1 1/2"	28,0	95	105	8,0	B-RA8N5N
	NPT 2"	28,0	95	105	8,0	B-RA8N6N
	NPT 2 1/2"	28,0	95	105	8,0	B-RA8N7N
NPT 3 1/2"	NPT 1 1/4"	28,0	110	123	10,0	B-RA9N4N
	NPT 1 1/2"	28,0	110	123	10,0	B-RA9N5N
	NPT 2"	28,0	110	123	10,0	B-RA9N6N
	NPT 2 1/2"	28,0	110	123	10,0	B-RA9N7N
	NPT 3"	28,0	110	123	10,0	B-RA9N8N
NPT 4"	NPT 1 1/2"	28,0	120	133,5	10,0	B-RA10N5N
	NPT 2"	28,0	120	133,5	10,0	B-RA10N6N
	NPT 2 1/2"	28,0	120	133,5	10,0	B-RA10N7N
	NPT 3"	28,0	120	133,5	10,0	B-RA10N8N

Thread Type **NPT** acc. to ANSI ASME B1.20.1 > **METRIC** acc. to ISO 965-3

Outer Thread Size (Male)	Inner Thread Size (Female)	Outer Thread Length	Spanner Width	Outer Ø	Height	Part Number
		TL mm	SW mm	D mm	h mm	
NPT 1/2"	M16x1,5	15,0	25	27,5	4,0	B-RA1N01M
NPT 3/4"	M16x1,5	15,0	30	33	4,0	B-RA2N01M
	M20x1,5	15,0	30	33	4,0	B-RA2N1M
NPT 1"	M16x1,5	15,0	36	39,5	4,0	B-RA3N01M
	M20x1,5	15,0	36	39,5	4,0	B-RA3N1M
	M25x1,5	15,0	36	39,5	4,0	B-RA3N2M
NPT 1 1/4"	M16x1,5	18,0	45	50	4,0	B-RA4N01M
	M20x1,5	18,0	45	50	4,0	B-RA4N1M
	M25x1,5	18,0	45	50	4,0	B-RA4N2M
	M32x1,5	18,0	45	50	4,0	B-RA4N3M
NPT 1 1/2"	M20x1,5	18,0	55	61	5,0	B-RA5N1M
	M25x1,5	18,0	55	61	5,0	B-RA5N2M
	M32x1,5	18,0	55	61	5,0	B-RA5N3M
	M40x1,5	18,0	55	61	5,0	B-RA5N4M
NPT 2"	M25x1,5	18,0	65	72	5,0	B-RA6N2M
	M32x1,5	18,0	65	72	5,0	B-RA6N3M
	M40x1,5	18,0	65	72	5,0	B-RA6N4M
	M50x1,5	18,0	65	72	5,0	B-RA6N5M
NPT 2 1/2"	M50x1,5	28,0	75	83	6,0	B-RA7N5M
	M60x1,5	28,0	75	83	6,0	B-RA7N60M
	M63x1,5	28,0	75	83	6,0	B-RA7N6M
NPT 3"	M63x1,5	28,0	95	105	8,0	B-RA8N6M
	M70x1,5	28,0	95	105	8,0	B-RA8N70M
	M75x1,5	28,0	95	105	8,0	B-RA8N7M
NPT 3 1/2"	M80x1,5	28,0	110	123	10,0	B-RA9N80M
	M85x1,5	28,0	110	123	10,0	B-RA9N85M
	M90x1,5	28,0	110	123	10,0	B-RA9N8M
NPT 4"	M80x1,5	28,0	120	133,5	10,0	B-RA10N80M
	M85x1,5	28,0	120	133,5	10,0	B-RA10N85M
	M90x1,5	28,0	120	133,5	10,0	B-RA10N8M
	M100x1,5	28,0	120	133,5	10,0	B-RA10N9M

Couplers for Ex d/e Applications

Technical Details						
Material Body	Brass, Brass Bickel Plated, Stainless Steel 316L					
Ingress Protection Rating	IP 68 - 5 Bar, 30 min IP 66					
Operating Temperature	Seal Material					
	<table border="1"> <tr> <td>CR (Chloroprene)</td> <td>Silicone</td> </tr> <tr> <td>Ex d/e/tb</td> <td>-40°C to +100°C</td> </tr> <tr> <td></td> <td>-60°C to +130°C</td> </tr> </table>	CR (Chloroprene)	Silicone	Ex d/e/tb	-40°C to +100°C	
CR (Chloroprene)	Silicone					
Ex d/e/tb	-40°C to +100°C					
	-60°C to +130°C					
Equipment For	• Gas & Dust potentially explosive atmospheres.					
Suitable for use in	Group II	Gas Group IIC	ZONE1/ZONE2			
	Group III	Dust Group IIIC	ZONE21/ZONE 22			
Equipment Marking	Ex II 2GD Ex db IIC Gb Ex eb IIC Gb Ex tb IIIC Db					
Marking Example	BMD B-RM.. CE 0722  II 2GD Ex e IIC Gb Ex tb IIIC Db Ta-40°C +100°C IP66/68 CESI 13 ATEX 066X IECEx CES 13.0022X					
Type Protection	Ex db ; Ex eb ; Ex tb					
Thread Type	<ul style="list-style-type: none"> • Metric (M) ISO 965-3 • Npt (N) ANSI ASME B1.20.1 • PG (P) DIN 40430 • (G) GAS UNI ISO 228/1 					
Approvals	Certificate Number	Standards				
	CESI 13 ATEX 066X	EN 60079-0:2012+A11:2013 EN 60079-1:2014 EN 60079-7:2015 EN 60079-31:2014				
	IECEx CES 13.0022X	IEC 60079-0:2011 Edition:6 IEC 60079-1:2014 Edition:7 IEC 60079-31:2013 Edition:2 IEC 60079-7:2015 Edition:5				
	№ TC RU C-TR.AA87.B.00941	ГОСТ 31610.0-2014 ГОСТ IEC 60079-1:2013 ГОСТ IEC 60079-31:2013				
	DNV 12.0150 X	ABNT NBR IEC 60079-0:2008, ABNT NBR IEC 60079-1:2009, ABNT NBR IEC 60079-7:2008, ABNT NBR IEC 60079-31:2011				
	E-14044	IEC/EN60079-0, IEC/EN60079-7, IEC/EN60079-31, IEC/EN60079-1 & IEC/EN 62444				
* For more information see our webpage.						
** The standard marking consists ATEX & IECEx only. Marking acc. to other standards on request.						

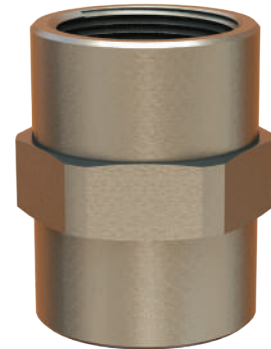
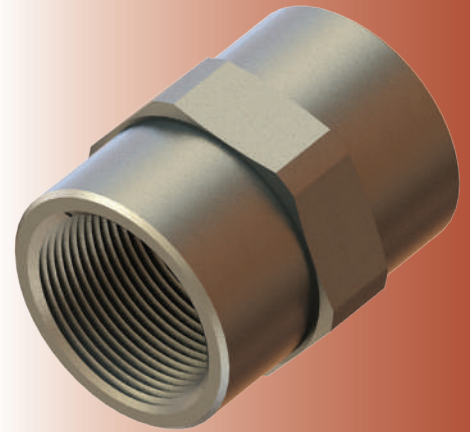

Order Coding	Material
Part Number	Mandatory
See table	B Brass BN Brass Nickel plated X Stainless steel 316L
Example	
B-RM5M4M	BN

ARIES

Couplers for Ex d/e Applications

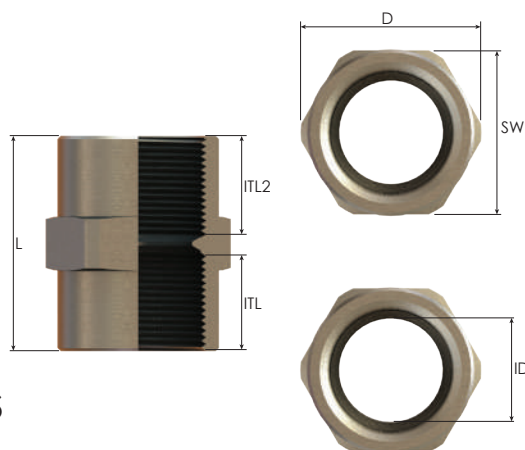

Thread Type **METRIC** > **METRIC** acc. to ISO 965-3

Inner Thread Size (Female)	Inner Thread Size 2 (Female)	Inner Thread Length	Inner Thread Length 2	Spanner Width	Outer Ø	Inner Ø	Total Height	Part Number
		ITL mm	ITL2 mm					
M16x1,5	M16x1,5	15,0	15,0	20	22,0	13,5	33,0	B-RM01M01M
M20x1,5	M16x1,5	15,0	15,0	25	27,5	13,5	32,0	B-RM1M01M
	M20x1,5	15,0	15,0	25	27,5	17,0	32,0	B-RM1M11M
M25x1,5	M16x1,5	15,0	15,0	32	35,0	13,5	35,0	B-RM2M01M
	M20x1,5	15,0	15,0	32	35,0	17,0	33,0	B-RM2M11M
	M25x1,5	15,0	15,0	32	35,0	22,0	33,0	B-RM2M2M
M32x1,5	M20x1,5	15,0	15,0	36	39,5	17,0	36,0	B-RM3M1M
	M25x1,5	15,0	15,0	36	39,5	22,0	34,0	B-RM3M2M
	M32x1,5	15,0	15,0	36	39,5	29,0	32,0	B-RM3M3M
M40x1,5	M25x1,5	18,0	15,0	45	50,0	22,0	40,0	B-RM4M2M
	M32x1,5	18,0	15,0	45	50,0	29,0	37,0	B-RM4M3M
	M40x1,5	18,0	18,0	45	50,0	37,0	38,0	B-RM4M4M
M50x1,5	M32x1,5	18,0	15,0	55	61,0	29,0	41,0	B-RM5M3M
	M40x1,5	18,0	18,0	55	61,0	37,0	40,0	B-RM5M4M
	M50x1,5	18,0	18,0	55	61,0	47,0	38,0	B-RM5M5M
M60x1,5	M40x1,5	18,0	18,0	68	75,0	36,0	45,0	B-RM6M4M
	M50x1,5	18,0	18,0	68	75,0	47,0	41,0	B-RM6M5M
	M60x1,5	18,0	18,0	68	75,0	55,0	40,0	B-RM6M60M
M63x1,5	M50x1,5	18,0	18,0	68	75,0	47,0	41,0	B-RM6M5M
	M60x1,5	18,0	18,0	68	75,0	55,0	40,0	B-RM6M60M
	M63x1,5	18,0	18,0	68	75,0	60,0	38,0	B-RM6M6M
M75x1,5	M63x1,5	18,0	18,0	80	88,5	60,0	41,0	B-RM7M6M
	M70x1,5	18,0	18,0	80	88,5	65,0	41,0	B-RM7M70M
	M75x1,5	18,0	18,0	80	88,5	72,0	38,0	B-RM7M7M
M80x1,5	M70x1,5	18,0	18,0	90	100,0	65,0	43,0	B-RM80M70M
	M75x1,5	18,0	18,0	90	100,0	72,0	40,0	B-RM80M7M
	M80x1,5	18,0	18,0	90	100,0	75,0	40,0	B-RM80M80M
M85x1,5	M75x1,5	18,0	18,0	95	105,0	72,0	41,0	B-RM85M7M
	M80x1,5	18,0	18,0	95	105,0	75,0	41,0	B-RM85M80M
	M85x1,5	18,0	18,0	95	105,0	80,0	40,0	B-RM85M85M
M90x1,5	M80x1,5	21,0	18,0	95	105,0	75,0	46,0	B-RM8M80M
	M85x1,5	21,0	18,0	95	105,0	80,0	44,0	B-RM8M85M
	M90x1,5	21,0	21,0	95	105,0	87,0	44,0	B-RM8M8M
M100x1,5	M85x1,5	21,0	18,0	110	123,0	80,0	48,0	B-RM9M85M
	M90x1,5	21,0	21,0	110	123,0	87,0	48,0	B-RM9M8M
	M100x1,5	21,0	21,0	110	123,0	95,0	46,0	B-RM9M9M
M110x1,5	M90x1,5	21,0	21,0	120	133,5	87,0	51,0	B-RM10M8M
	M100x1,5	21,0	21,0	120	133,5	95,0	50,0	B-RM10M9M
	M110x1,5	21,0	21,0	120	133,5	107,0	44,0	B-RM10M10M

ARIES Couplers for Ex d/e Applications

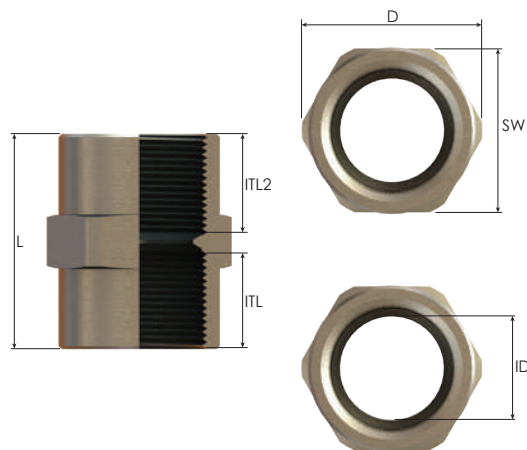

Thread Type **NPT > NPT** acc. to ANSI ASME B1.20.1

Inner Thread Size (Female)	Inner Thread Size 2 (Female)	Inner Thread Length	Inner Thread Length 2	Spanner Width	Outer Ø	Inner Ø	Total Height	Part Number
		ITL mm	ITL2 mm	SW mm	D mm	ID mm	L mm	
NPT 3/8"	NPT 3/8"	15,0	15,0	20	22,0	12,5	32,0	B-RM01N01N
NPT 1/2"	NPT 3/8"	15,0	15,0	25	27,5	12,5	33,0	B-RM1N01N
	NPT 1/2"	15,0	15,0	25	27,5	16,0	32,0	B-RM1N11N
NPT 3/4"	NPT 3/8"	15,0	15,0	32	35,0	12,5	35,0	B-RM2N01N
	NPT 1/2"	15,0	15,0	32	35,0	16,0	33,0	B-RM2N11N
	NPT 3/4"	15,0	15,0	32	35,0	21,0	32,0	B-RM2N21N
NPT 1"	NPT 1/2"	15,0	15,0	36	39,5	16,0	36,0	B-RM3N11N
	NPT 3/4"	15,0	15,0	36	39,5	21,0	34,0	B-RM3N21N
	NPT 1"	15,0	15,0	36	39,5	27,0	32,0	B-RM3N31N
NPT 1 1/4"	NPT 3/4"	18,0	15,0	45	50,0	21,0	40,0	B-RM4N21N
	NPT 1"	18,0	15,0	45	50,0	27,0	38,0	B-RM4N31N
	NPT 1 1/4"	18,0	18,0	45	50,0	35,0	39,0	B-RM4N41N
NPT 1 1/2"	NPT 1"	18,0	15,0	55	61,0	27,0	40,0	B-RM5N31N
	NPT 1 1/4"	18,0	18,0	55	61,0	35,0	41,0	B-RM5N41N
	NPT 1 1/2"	18,0	18,0	55	61,0	41,5	39,0	B-RM5N51N
NPT 2"	NPT 1 1/4"	18,0	18,0	65	72,0	35,0	45,0	B-RM6N41N
	NPT 1 1/2"	18,0	18,0	65	72,0	41,5	43,0	B-RM6N51N
	NPT 2"	18,0	18,0	65	72,0	53,5	39,0	B-RM6N61N
NPT 2 1/2"	NPT 1 1/2"	28,0	18,0	80	88,5	41,5	56,0	B-RM7N51N
	NPT 2"	28,0	18,0	80	88,5	53,5	53,0	B-RM7N61N
	NPT 2 1/2"	28,0	28,0	80	88,5	64,0	60,0	B-RM7N71N
NPT 3"	NPT 2"	28,0	18,0	95	105,0	53,5	58,0	B-RM8N61N
	NPT 2 1/2"	28,0	28,0	95	105,0	64,0	64,0	B-RM8N71N
	NPT 3"	28,0	28,0	95	105,0	80,0	59,0	B-RM8N81N
NPT 3 1/2"	NPT 2 1/2"	28,0	28,0	110	123,0	64,0	69,0	B-RM9N71N
	NPT 3"	28,0	28,0	110	123,0	80,0	64,0	B-RM9N81N
	NPT 3 1/2"	28,0	28,0	110	123,0	90,0	62,0	B-RM9N91N
NPT 4"	NPT 3"	28,0	28,0	120	133,5	80,0	62,0	B-RM10N81N
	NPT 3 1/2"	28,0	28,0	120	133,5	90,0	65,0	B-RM10N91N
	NPT 4"	28,0	28,0	120	133,5	105,0	59,0	B-RM10N101N

ARIES



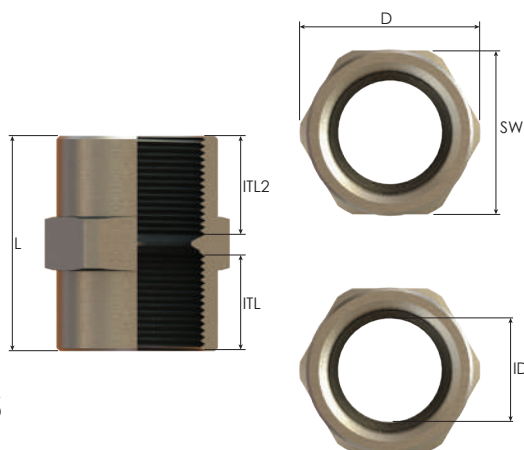



Couplers for Ex d/e Applications



Thread Type **NPT** acc. to ANSI ASME B1.20.1 > **METRIC** acc. to ISO 965-3

Inner Thread Size (Female)	Inner Thread Size 2 (Female)	Inner Thread Length	Inner Thread Length 2	Spanner Width	Outer Ø	Inner Ø	Total Height	Part Number
		ITL mm	ITL2 mm					
NPT 3/8"	M16x1,5	15,0	15,0	20	22,0	12,5	32,0	B-RM01N01M
NPT 1/2"	M16x1,5	15,0	15,0	25	27,5	14,0	33,0	B-RM1N01M
	M20x1,5	15,0	15,0	25	27,5	16,0	32,0	B-RM1N1M
NPT 3/4"	M16x1,5	15,0	15,0	32	35,0	12,5	35,0	B-RM2N01M
	M20x1,5	15,0	15,0	32	35,0	16,0	34,0	B-RM2N1M
	M25x1,5	15,0	15,0	32	35,0	21,0	33,0	B-RM2N2M
NPT 1"	M20x1,5	15,0	15,0	36	39,5	16,0	36,0	B-RM3N1M
	M25x1,5	15,0	15,0	36	39,5	21,0	34,0	B-RM3N2M
	M32x1,5	15,0	15,0	36	39,5	27,0	33,0	B-RM3N3M
NPT 1 1/4"	M25x1,5	18,0	15,0	45	50,0	21,0	40,0	B-RM4N2M
	M32x1,5	18,0	15,0	45	50,0	27,0	38,0	B-RM4N3M
	M40x1,5	18,0	18,0	45	50,0	36,0	39,0	B-RM4N4M
NPT 1 1/2"	M32x1,5	18,0	15,0	55	61,0	27,0	41,0	B-RM5N3M
	M40x1,5	18,0	18,0	55	61,0	36,0	41,0	B-RM5N4M
	M50x1,5	18,0	18,0	55	61,0	41,5	40,0	B-RM5N5M
NPT 2"	M50x1,5	18,0	18,0	65	72,0	47,0	41,0	B-RM6N5M
	M60x1,5	18,0	18,0	65	72,0	53,5	41,0	B-RM6N60M
	M63x1,5	18,0	18,0	20	72,0	53,5	41,0	B-RM6N6M
NPT 2 1/2"	M63x1,5	28,0	18,0	80	88,5	58,0	51,0	B-RM7N6M
	M70x1,5	28,0	18,0	80	88,5	63,0	52,0	B-RM7N70M
	M75x1,5	28,0	18,0	80	88,5	63,0	52,0	B-RM7N7M
NPT 3"	M80x1,5	28,0	18,0	95	105,0	75,0	51,0	B-RM8N80M
	M85x1,5	28,0	18,0	95	105,0	78,0	51,0	B-RM8N85M
	M90x1,5	28,0	21,0	95	105,0	79,0	55,0	B-RM8N8M
NPT 3 1/2"	M85x1,5	28,0	18,0	110	123,0	80,0	55,0	B-RM9N85M
	M90x1,5	28,0	21,0	110	123,0	84,0	56,0	B-RM9N8M
	M100x1,5	28,0	21,0	110	123,0	90,0	56,0	B-RM9N9M
NPT 4"	M90x1,5	28,0	21,0	120	133,5	85,0	60,0	B-RM10N8M
	M100x1,5	28,0	21,0	120	133,5	95,0	57,0	B-RM10N9M
	M110x1,5	28,0	21,0	120	133,5	103,0	55,0	B-RM10N10M

Nipples for Ex d/e Applications

Technical Details	
Material	Body Brass, Brass Nickel Plated, Stainless Steel 316L O-ring CR (Chloroprene), Silicone
Ingress Protection Rating	IP 68 - 5 Bar, 30 min IP 66
Operating Temperature	O-ring Material CR (Chloroprene) -40°C to +100°C Silicone -60°C to +130°C
Equipment For	• Gas & Dust potentially explosive atmospheres.
Suitable for use in	Group II Gas Group IIC ZONE1/ZONE2 Group III Dust Group IIIC ZONE21/ZONE 22
Equipment Marking	Ex II 2GD Ex db IIC Gb Ex eb IIC Gb Ex tb IIIC Db
Marking Example *	BMD B-RN.. CE 0722  II 2GD Ex db IIC Gb Ex eb IIC Gb Ex tb IIIC Db Ta-40°C to +100°C IP66/68 CESI 13 ATEX 066X IECEx CES 13.0022X • Metric (M) ISO Pitch 1,5 • Npt (N) ANSI ASME B1.20.1 • PG (P) DIN 40430 • (G) GAS UNI ISO 228/1
Thread Type	
Accessories	• Gaskets (Washers)
Remarks	• Accessories must be ordered separately. • O-ring only available when male thread is Metric.
Approvals	Certificate Number Standards
	CESI 13 ATEX 066X EN 60079-0:2012+A11:2013 EN 60079-1:2014 EN 60079-7:2015 EN 60079-31:2014
	IECEx CES 13.0022X IEC 60079-0:2011 Edition:6 IEC 60079-1:2014 Edition:7 IEC 60079-31:2013 Edition:2 IEC 60079-7:2015 Edition:5
	№ TC RU C-TR.AA87.B.00941 ГОСТ 31610.0-2014 ГОСТ IEC 60079-1:2013 ГОСТ IEC 60079-31:2013
	DNV 12.0150 X ABNT NBR IEC 60079-0:2008, ABNT NBR IEC 60079-1:2009, ABNT NBR IEC 60079-7:2008, ABNT NBR IEC 60079-31:2011
	E-14044 IEC/EN60079-0, IEC/EN60079-7, IEC/EN60079-31, IEC/EN60079-1 & IEC/EN 62444

-For more information see our webpage.

* The standard marking consists ATEX & IECEx only. Marking acc. to other standards on request.

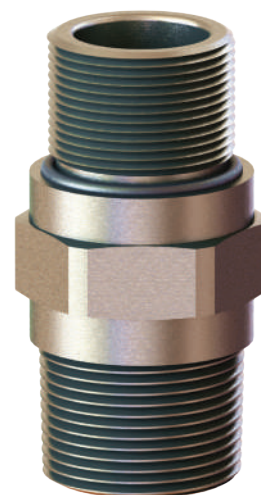

Order Coding				
Part Number	Material	Seal	-	Gasket
Mandatory	Mandatory	Mandatory	-	Option
See table	B Brass BN Brass Nickel plated X Stainless Steel 316L	C Chloroprene S Silicone	-	WC Chloroprene WS Silicone WF Fiber
Example				
B-RN8M8M	A	C	-	WS

PAVO

Nipples for Ex d/e Applications

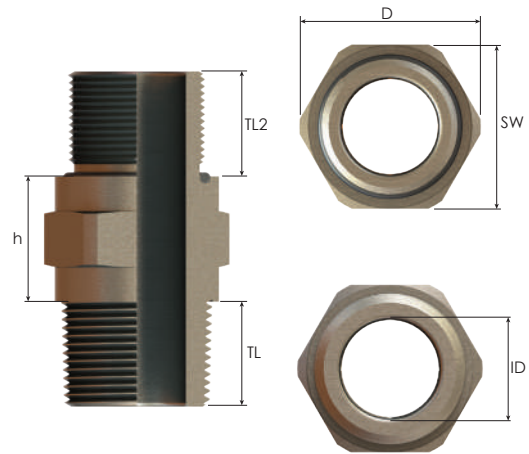

Thread Type **METRIC** > **METRIC** acc. to ISO 965-3

Outer Thread Size (Male)	Outer Thread Size 2 (Male)	Outer Thread Length	Outer Thread Length 2	Spanner Width	Outer Ø	Inner Ø	Height	Part Number
		TL mm	TL2 mm	SW mm	D mm	ID mm	h mm	
M16x1,5	M16x1,5	15,0	15,0	20	22,0	10,0	18,0	B-RN01M01M
M20x1,5	M16x1,5	15,0	15,0	24	26,5	10,0	18,0	B-RN1M01M
	M20x1,5	15,0	15,0	24	26,5	14,0	18,0	B-RN1M1M
M25x1,5	M16x1,5	15,0	15,0	32	35,0	10,0	20,0	B-RN2M01M
	M20x1,5	15,0	15,0	32	35,0	14,0	20,0	B-RN2M1M
	M25x1,5	15,0	15,0	32	35,0	19,0	20,0	B-RN2M2M
M32x1,5	M20x1,5	15,0	15,0	36	39,5	14,0	20,0	B-RN3M1M
	M25x1,5	15,0	15,0	36	39,5	19,0	20,0	B-RN3M2M
	M32x1,5	15,0	15,0	36	39,5	26,0	20,0	B-RN3M3M
M40x1,5	M25x1,5	15,0	18,0	45	50,0	19,0	20,0	B-RN4M2M
	M32x1,5	15,0	18,0	45	50,0	26,0	20,0	B-RN4M3M
	M40x1,5	18,0	18,0	45	50,0	34,0	20,0	B-RN4M4M
M50x1,5	M32x1,5	15,0	18,0	55	61,0	26,0	22,0	B-RN5M3M
	M40x1,5	18,0	18,0	55	61,0	34,0	22,0	B-RN5M4M
	M50x1,5	18,0	18,0	55	61,0	44,0	22,0	B-RN5M5M
M60x1,5	M40x1,5	18,0	18,0	70	77,0	34,0	22,0	B-RN6M4M
	M50x1,5	18,0	18,0	70	77,0	44,0	22,0	B-RN6M5M
	M60x1,5	18,0	18,0	70	77,0	54,0	22,0	B-RN6M6M
M63x1,5	M50x1,5	18,0	18,0	70	77,0	44,0	22,0	B-RN6M5M
	M60x1,5	18,0	18,0	70	77,0	54,0	22,0	B-RN6M6M
	M63x1,5	18,0	18,0	70	77,0	57,0	22,0	B-RN6M6M
M70x1,5	M60x1,5	18,0	18,0	80	88,5	54,0	26,0	B-RN7M6M
	M63x1,5	18,0	18,0	80	88,5	57,0	26,0	B-RN7M6M
	M70x1,5	18,0	18,0	80	88,5	64,0	26,0	B-RN7M7M
M75x1,5	M63x1,5	18,0	18,0	85	94,0	57,0	26,0	B-RN7M6M
	M70x1,5	18,0	18,0	85	94,0	64,0	26,0	B-RN7M7M
	M75x1,5	18,0	18,0	85	94,0	69,0	26,0	B-RN7M7M
M80x1,5	M70x1,5	18,0	18,0	90	100,0	64,0	26,0	B-RN8M7M
	M75x1,5	18,0	18,0	90	100,0	69,0	26,0	B-RN8M7M
	M80x1,5	18,0	18,0	90	100,0	74,0	26,0	B-RN8M8M
M85x1,5	M75x1,5	18,0	18,0	95	105,0	69,0	26,0	B-RN8M7M
	M80x1,5	18,0	18,0	95	105,0	74,0	26,0	B-RN8M8M
	M85x1,5	18,0	18,0	95	105,0	79,0	26,0	B-RN8M8M
M90x1,5	M80x1,5	18,0	21,0	100	111,0	74,0	26,0	B-RN8M8M
	M85x1,5	18,0	21,0	100	111,0	79,0	26,0	B-RN8M8M
	M90x1,5	21,0	21,0	100	111,0	84,0	26,0	B-RN8M8M
M100x1,5	M85x1,5	18,0	21,0	110	123,0	79,0	27,0	B-RN9M8M
	M90x1,5	21,0	21,0	110	123,0	84,0	27,0	B-RN9M8M
	M100x1,5	21,0	21,0	110	123,0	93,0	27,0	B-RN9M9M
M110x1,5	M90x1,5	21,0	21,0	120	133,5	84,0	27,0	B-RN10M8M
	M100x1,5	21,0	21,0	120	133,5	93,0	27,0	B-RN10M9M
	M110x1,5	21,0	21,0	120	133,5	100,0	27,0	B-RN10M10M

PAVO

Nipples for Ex d/e Applications

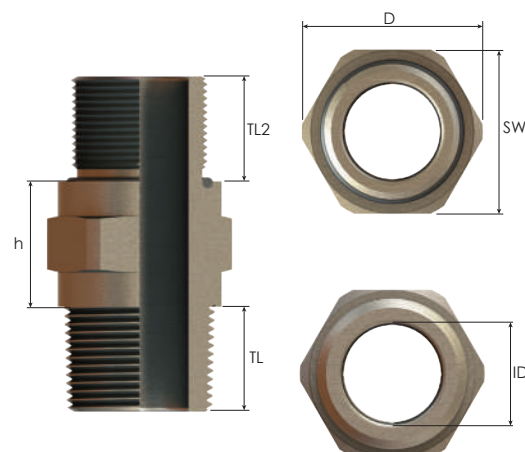

Thread Type NPT > NPT acc. to ANSI ASME B1.20.1								
Outer Thread Size (Male)	Outer Thread Size 2 (Male)	Outer Thread Length	Outer Thread Length 2	Spanner Width	Outer Ø	Inner Ø	Height	Part Number
		TL mm	TL2 mm	SW mm	D mm	ID mm	h mm	
NPT 3/8"	NPT 3/8"	15,0	15,0	20	22,0	12,0	18,0	B-RN01N01N
NPT 1/2"	NPT 3/8"	15,0	15,0	24	26,5	12,0	18,0	B-RN1N01N
	NPT 1/2"	15,0	15,0	24	26,5	15,5	18,0	B-RN1N1N
NPT 3/4"	NPT 3/8"	15,0	15,0	32	35,0	12,0	20,0	B-RN2N01N
	NPT 1/2"	15,0	15,0	32	35,0	15,5	20,0	B-RN2N1N
	NPT 3/4"	15,0	15,0	32	35,0	19,0	20,0	B-RN2N2N
NPT 1"	NPT 1/2"	15,0	15,0	36	39,5	15,5	20,0	B-RN3N1N
	NPT 3/4"	15,0	15,0	36	39,5	19,0	20,0	B-RN3N2N
	NPT 1"	15,0	15,0	36	39,5	25,0	20,0	B-RN3N3N
NPT 1 1/4"	NPT 3/4"	15,0	18,0	45	50,0	19,0	23,0	B-RN4N2N
	NPT 1"	15,0	18,0	45	50,0	25,0	23,0	B-RN4N3N
	NPT 1 1/4"	18,0	18,0	45	50,0	33,0	20,0	B-RN4N4N
NPT 1 1/2"	NPT 1"	15,0	18,0	55	61,0	25,0	25,0	B-RN5N3N
	NPT 1 1/4"	18,0	18,0	55	61,0	33,0	22,0	B-RN5N4N
	NPT 1 1/2"	18,0	18,0	55	61,0	40,0	22,0	B-RN5N5N
NPT 2"	NPT 1 1/4"	18,0	18,0	65	72,0	33,0	22,0	B-RN6N4N
	NPT 1 1/2"	18,0	18,0	65	72,0	40,0	22,0	B-RN6N5N
	NPT 2"	18,0	18,0	65	72,0	52,0	22,0	B-RN6N6N
NPT 2 1/2"	NPT 1 1/2"	18,0	28,0	80	88,5	40,0	36,0	B-RN7N5N
	NPT 2"	18,0	28,0	80	88,5	52,0	36,0	B-RN7N6N
	NPT 2 1/2"	28,0	28,0	80	88,5	62,0	26,0	B-RN7N7N
NPT 3"	NPT 2"	18,0	28,0	95	105,0	52,0	36,0	B-RN8N6N
	NPT 2 1/2"	28,0	28,0	95	105,0	62,0	26,0	B-RN8N7N
	NPT 3"	28,0	28,0	95	105,0	75,0	26,0	B-RN8N8N
NPT 3 1/2"	NPT 2 1/2"	28,0	28,0	110	123,0	62,0	27,0	B-RN9N7N
	NPT 3"	28,0	28,0	110	123,0	75,0	27,0	B-RN9N8N
	NPT 3 1/2"	28,0	28,0	110	123,0	87,5	27,0	B-RN9N9N
NPT 4"	NPT 3"	28,0	28,0	120	133,5	75,0	27,0	B-RN10N8N
	NPT 3 1/2"	28,0	28,0	120	133,5	87,5	27,0	B-RN10N9N
	NPT 4"	28,0	28,0	120	133,5	100,0	27,0	B-RN10N10N

PAVO

Nipples for Ex d/e Applications

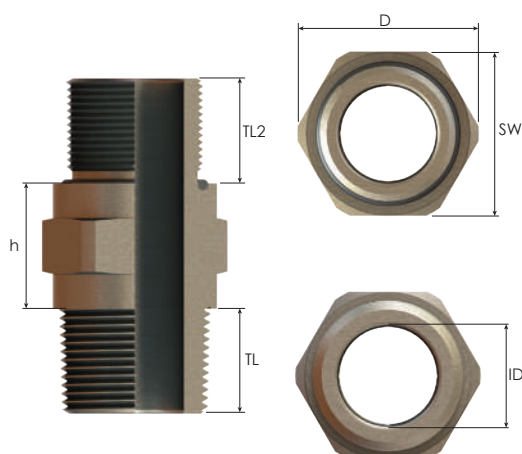







Thread Type **NPT** acc. to ANSI ASME B1.20.1 > **METRIC** acc. to ISO 965-3

Outer Thread Size (Male)	Inner Thread Size 2 (Male)	Outer Thread Length	Outer Thread Length 2	Spanner Width	Outer Ø	Inner Ø	Height	Part Number
		TL mm	TL 2 mm	SW mm	D mm	ID mm	h mm	
NPT 3/8"	M16x1,5	15,0	15,0	20	22,0	10,0	18,0	B-RN01N01M
NPT 1/2"	M16x1,5	15,0	15,0	24	26,5	10,0	18,0	B-RN1N01M
	M20x1,5	15,0	15,0	24	26,5	14,0	18,0	B-RN1N1M
NPT 3/4"	M16x1,5	15,0	15,0	32	35,0	10,0	20,0	B-RN2N01M
	M20x1,5	15,0	15,0	32	35,0	14,0	20,0	B-RN2N1M
	M25x1,5	15,0	15,0	32	35,0	19,0	20,0	B-RN2N2M
NPT 1"	M20x1,5	15,0	15,0	36	39,5	14,0	20,0	B-RN3N1M
	M25x1,5	15,0	15,0	36	39,5	19,0	20,0	B-RN3N2M
	M32x1,5	15,0	15,0	36	39,5	26,0	20,0	B-RN3N3M
NPT 1 1/4"	M25x1,5	15,0	18,0	45	50,0	19,0	20,0	B-RN4N2M
	M32x1,5	15,0	18,0	45	50,0	26,0	20,0	B-RN4N3M
	M40x1,5	18,0	18,0	45	50,0	33,0	20,0	B-RN4N4M
NPT 1 1/2"	M32x1,5	15,0	18,0	55	61,0	26,0	22,0	B-RN5N3M
	M40x1,5	18,0	18,0	55	61,0	33,0	22,0	B-RN5N4M
	M50x1,5	18,0	18,0	55	61,0	40,0	22,0	B-RN5N5M
NPT 2"	M50x1,5	18,0	18,0	65	72,0	40,0	22,0	B-RN6N5M
	M60x1,5	18,0	18,0	65	72,0	50,0	22,0	B-RN6N6M
	M63x1,5	18,0	18,0	70	77,0	52,0	22,0	B-RN6N6M
NPT 2 1/2"	M63x1,5	18,0	28,0	80	88,5	52,0	26,0	B-RN7N6M
	M70x1,5	18,0	28,0	80	88,5	57,0	26,0	B-RN7N7M
	M75x1,5	18,0	28,0	85	94,0	62,0	26,0	B-RN7N7M
NPT 3"	M80x1,5	18,0	28,0	95	105,0	67,0	26,0	B-RN8N8M
	M85x1,5	18,0	28,0	95	105,0	72,0	26,0	B-RN8N85M
	M90x1,5	21,0	28,0	95	111,0	75,0	26,0	B-RN8N8M
NPT 3 1/2"	M85x1,5	18,0	28,0	110	123,0	72,0	27,0	B-RN9N85M
	M90x1,5	21,0	28,0	110	123,0	75,0	27,0	B-RN9N8M
	M100x1,5	21,0	28,0	110	123,0	87,5	27,0	B-RN9N9M
NPT 4"	M90x1,5	21,0	28,0	120	133,5	75,0	27,0	B-RN10N8M
	M100x1,5	21,0	28,0	120	133,5	87,5	27,0	B-RN10N9M
	M110x1,5	21,0	28,0	120	133,5	100,0	27,0	B-RN10N10M

Hexagonal Plugs for Ex d/e Applications

AQUILA HEXAGONAL



Technical Details		
Material	Body	Brass, Brass Nickel Plated, Stainless Steel 316L
	O-ring	CR (Chloroprene), Silicone
Ingress Protection Rating		IP 68 - 5 Bar, 30 min IP 66
Operating Temperature	O-ring Material	
	CR (Chloroprene)	-40°C to +100°C
	Silicone	60°C to +130°C
Equipment For	• Gas & Dust potentially explosive atmospheres.	
Suitable for use in	Group II	Gas Group IIC ZONE1/ZONE2
	Group III	Dust Group IIIC ZONE21/ZONE 22
Marking Example *	BMD MB-TS.. CE 0722  II 2GD Ex db IIC Gb Ex eb IIC Gb Ta-40°C to +100°C IP66/68 CESI 13 ATEX 066X IECEx CES 13.0022X	
Type Protection	Ex d ; Ex e ; Ex tb *For NB-TS type only Ex e ; Ex tb.	
Thread Type	• Metric (M) ISO Pitch 1,5 • Npt (N) ANSI ASME B1.20.1	
Accessories	• Gaskets (Washers) • Lock nuts	
Remarks	• O-ring available in Metric, PG and G threads. • Accessories must be ordered separately.	
Approvals	Certificate Number	Standards
	CESI 13 ATEX 066X	EN 60079-0:2012+A11:2013 EN 60079-1:2014 EN 60079-7:2015 EN 60079-31:2014
	IECEx CES 13.0022X	IEC 60079-0:2011 Edition:6 IEC 60079-1:2014 Edition:7 IEC 60079-31:2013 Edition:2 IEC 60079-7:2015 Edition:5
	E493186	UL 60079-0, UL 60079-1, UL 60079-7 UL 60079-31 CAN/CSA-C22.2 No. 60079-0:15, CAN/CSA-C22.2 No. 60079-1:16 CAN/CSA C22.2 No. 60079-7:12, CAN/CSA-C22.2 No. 60079-31:15,
	E467237	UL 508A C22.2 No. 14-13
	No TC RU C-TR.AA87.B.00941	ГОСТ 31610.0-2014 ГОСТ IEC 60079-1:2013 ГОСТ IEC 60079-31:2013
	DNV 12.0150 X	ABNT NBR IEC 60079-0:2008, ABNT NBR IEC 60079-1:2009, ABNT NBR IEC 60079-7:2008, ABNT NBR IEC 60079-31:2011
	E-14044	IEC/EN60079-0, IEC/EN60079-7, IEC/EN60079-31, IEC/EN60079-1 & IEC/EN 62444

-For more information see our webpage.

* The standard marking consists ATEX & IECEx only. Marking acc. to other standards on request.

Order Coding			
Part Number	Material	Seal	- Gasket (Washer)
Mandatory	Mandatory	Mandatory	- Option
See table	B Brass BN Brass Nickel plated X Stainless steel 316L	C Chloroprene S Silicione	- WC Chloroprene WS Silicone WF Fiber
Example			
B-TS3M	B	C	- WC

AQUILA HEXAGONAL Round Plugs for Ex d/e Applications

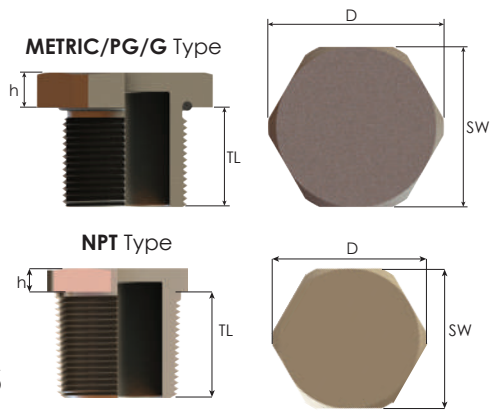

Thread Type METRIC acc. to ISO 965-3					
Outer Thread Size (Male)	Outer Thread Length		Spanner Width		Part Number
	TL mm	SW mm	Outer Ø mm	Height h mm	
M16x1,5	15,5	22	24,0	5,5	B-TS01M
M20x1,5	15,5	25	27,5	5,5	B-TS1M
M25x1,5	15,5	30	33,0	5,5	B-TS2M
M32x1,5	15,5	37	41,0	5,5	B-TS3M
M40x1,5	17,5	45	50,0	5,5	B-TS4M
M50x1,5	17,5	55	61,0	5,5	B-TS5M
M60x1,5	17,5	70	77,0	5,5	B-TS60M
M63x1,5	17,5	70	77,0	5,5	B-TS6M
M70x1,5	18,0	80	89,0	7,0	B-TS70M
M75x1,5	20,0	85	94,0	5,0	B-TS7M
M80x1,5	20,0	90	100,0	5,0	B-TS80M
M85x1,5	20,0	95	105,0	5,0	B-TS85M
M90x1,5	20,0	100	111,0	5,0	B-TS8M
M100x1,5	20,0	110	123,0	5,0	B-TS9M
M110x1,5	20,0	120	133,5	5,0	B-TS10M

Thread Type PG acc. to DIN 40430					
Outer Thread Size (Male)	Outer Thread Length		Spanner Width		Part Number
	TL mm	SW mm	Outer Ø mm	Height h mm	
PG 9	16,5	20	22,0	5,5	B-TS2P
PG 11	16,5	25	27,5	5,5	B-TS3P
PG 13,5	16,5	25	27,5	5,5	B-TS4P
PG 16	16,5	27	30,0	5,5	B-TS5P
PG 21	17,0	35	38,5	5,0	B-TS6P
PG 29	17,0	42	46,5	5,0	B-TS7P
PG 36	17,0	55	61,0	5,0	B-TS8P
PG 42	17,0	60	66,5	5,0	B-TS9P
PG 48	17,0	65	72,0	5,0	B-TS10P

Thread Type G acc. to GAS UNI ISO 228/1					
Outer Thread Size (Male)	Outer Thread Length		Spanner Width		Part Number
	TL mm	SW mm	Outer Ø mm	Height h mm	
G 3/8"	17,5	22	24,0	5,5	B-TS01C
G 1/2"	18,0	25	27,5	5,0	B-TS1C
G 3/4"	18,0	32	35,5	5,0	B-TS2C
G 1"	22,0	37	41,0	5,0	B-TS3C
G 1 1/4"	22,0	45	50,0	5,0	B-TS4C
G 1 1/2"	22,0	55	61,0	5,0	B-TS5C
G 2"	22,0	65	72,0	5,0	B-TS6C
G 2 1/2"	22,0	85	94,0	8,0	B-TS7C
G 3"	22,0	95	105,0	8,0	B-TS8C
G 3 1/2"	22,0	110	123,0	8,0	B-TS9C
G 4"	22,0	120	133,5	8,0	B-TS10C

Thread Type NPT acc. to ANSI ASME B1.20.1					
Outer Thread Size (Male)	Outer Thread Length		Spanner Width		Part Number
	TL mm	SW mm	Outer Ø mm	Height h mm	
NPT 3/8"	16,0	20	22,0	4,0	NB-TS01N
NPT 1/2"	18,0	24	26,5	4,0	NB-TS1N
NPT 3/4"	18,0	28	31,0	4,0	NB-TS2N
NPT 1"	21,0	35	38,5	4,0	NB-TS3N
NPT 1 1/4"	21,0	45	50,0	4,0	NB-TS4N
NPT 1 1/2"	21,0	50	55,5	5,0	NB-TS5N
NPT 2"	21,0	65	72,0	5,0	NB-TS6N
NPT 2 1/2"	28,0	75	83,0	5,0	NB-TS7N
NPT 3"	28,0	95	105,0	5,0	NB-TS8N
NPT 3 1/2"	28,0	100	123,0	5,0	NB-TS9N
NPT 4"	28,0	120	134,0	5,0	NB-TS10N

*NPT type is only Ex e.

Round Plugs for Ex d/e Applications

AQUILA ROUND



Technical Details		
Material	Body: Brass, Brass Nickel Plated, Stainless Steel 316L O-ring: CR (Chloroprene), Silicone	
Ingress Protection Rating	IP 68 - 5 Bar, 30 min IP 66	
Operating Temperature	O-ring Material CR (Chloroprene) : -40°C to +100°C Silicone : 60°C to +130°C	
Equipment For	• Gas & Dust potentially explosive atmospheres.	
Suitable for use in	Group II Gas Group IIC ZONE1/ZONE2 Group III Dust Group IIIC ZONE21/ZONE 22	
Marking Example *	BMD B-TS.. CE 0722 II 2GD Ex db IIC Gb Ex eb IIC Gb Ta-40°C to +100°C IP66/68 CESI 13 ATEX 066X IECEx CES 13.0022X	
Type Protection	Ex d ; Ex e ; Ex tb	
Thread Type	• Metric (M) ISO Pitch 1,5 • Npt (N) ANSI ASME B1.20.1 • PG (P) DIN 40430 • (G)GAS UNI ISO 228/1	
Accessories	• Gaskets (Washers) • Lock nuts	
Remarks	• The Aquila NPT type plugs can be only used on threaded enclosure. • Lock nuts and gaskets can not be used with NPT type Round Aquila. • O-ring only available in Metric threads. • Accessories must be ordered separately.	
Approvals	Certificate Number	Standards
	CESI 13 ATEX 066X	EN 60079-0:2012+A11:2013 EN 60079-1:2014 EN 60079-7:2015 EN 60079-31:2014
	IECEx CES 13.0022X	IEC 60079-0:2011 Edition:6 IEC 60079-1:2014 Edition:7 IEC 60079-31:2013 Edition:2 IEC 60079-7:2015 Edition:5
	E493186	UL 60079-0, UL 60079-1, UL 60079-7 UL 60079-31 CAN/CSA-C22.2 No. 60079-0:15, CAN/CSA-C22.2 No. 60079-1:16 CAN/CSA C22.2 No. 60079-7:12, CAN/CSA-C22.2 No. 60079-31:15.
	E467237	UL 508A C22.2 No. 14-13
	№ TC RU C-TR.AA87.B.00941	ГОСТ 31610.0-2014 ГОСТ IEC 60079-1:2013 ГОСТ IEC 60079-31:2013
	DNV 12.0150 X	ABNT NBR IEC 60079-0:2008, ABNT NBR IEC 60079-1:2009, ABNT NBR IEC 60079-7:2008, ABNT NBR IEC 60079-31:2011
	E-14044	IEC/EN60079-0, IEC/EN60079-7, IEC/EN60079-31, IEC/EN60079-1 & IEC/EN 62444



-For more information see our webpage.

* The standard marking consists ATEX & IECEx only. Marking acc. to other standards on request.

Order Coding			
Part Number	Material	Seal	Gasket (Washer)
Mandatory	Mandatory	Mandatory	- Option
See table	B Brass BN Brass Nickel plated X Stainless steel 316L	C Chloroprene S Silicione	- WC Chloroprene WS Silicone WF Fiber
Example			
NB -TS3N	B	C	- WC

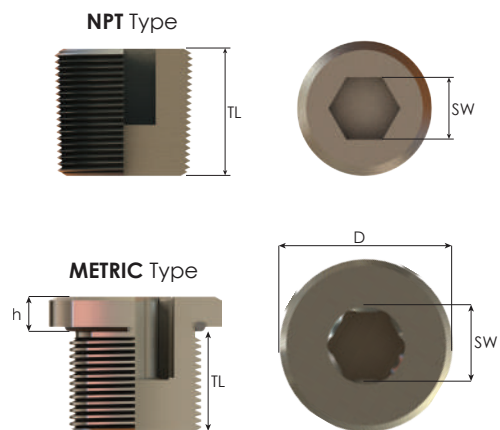

AQUILA ROUND

Round Plugs for Ex d/e Applications

Thread Type METRIC acc. to ISO 965-3					
Outer Thread Size (Male)	Outer Thread Length	Allen Screw Spanner Width	Outer Ø	Height	Part Number
	TL mm	SW mm	D mm	h mm	
M16x1,5	15,5	10	22,0	3,5	MB-TS01M
M20x1,5	15,5	10	26,0	4,5	MB-TS1M
M25x1,5	15,5	10	30,0	4,5	MB-TS2M
M32x1,5	15,5	14	37,0	4,5	MB-TS3M
M40x1,5	17,5	14	46,0	4,5	MB-TS4M
M50x1,5	17,5	14	56,0	4,5	MB-TS5M
M60x1,5	17,5	14	68,0	4,5	MB-TS60M
M63x1,5	17,5	14	70,0	4,5	MB-TS6M
M70x1,5	20,0	14	78,0	4,5	MB-TS70M
M75x1,5	20,0	14	83,0	4,5	MB-TS7M
M80x1,5	20,0	14	88,0	5,0	MB-TS80M
M85x1,5	20,0	14	94,0	5,0	MB-TS85M
M90x1,5	20,0	16	98,0	5,0	MB-TS8M
M100x1,5	20,0	16	108,0	5,0	MB-TS9M
M110x1,5	20,0	16	118,0	5,0	MB-TS10M

Thread Type NPT acc. to ANSI ASME B1.20.1					
Outer Thread Size (Male)	Outer Thread Length	Allen Screw Spanner Width	Outer Ø	Height	Part Number
	TL mm	SW mm	D mm	h mm	
NPT 3/8"	15,0	6	-	-	B-TS01N
NPT 1/2"	20,0	10	-	-	B-TS1N
NPT 3/4"	20,0	10	-	-	B-TS2N
NPT 1"	25,0	14	-	-	B-TS3N
NPT 1 1/4"	25,0	14	-	-	B-TS4N
NPT 1 1/2"	25,0	14	-	-	B-TS5N
NPT 2"	25,0	14	-	-	B-TS6N
NPT 2 1/2"	32,0	14	-	-	B-TS7N
NPT 3"	32,0	16	-	-	B-TS8N
NPT 3 1/2"	32,0	16	-	-	B-TS9N
NPT 4"	33,0	16	-	-	B-TS10N

bimed

CABLE GLANDS for NON-ARMOURED CIRCULAR CABLES for Gas & Dust Application



Lyra
Hi-Lyra
Vega

252 - 253
254 - 257
258 - 261

Ex Glands / Group II-III / Gas & Dust



A cable gland is a fitting that connects a cable to an electrical source, and also is able to secure the cable so it will not escape. Cable gland units are placed into different categories, depending on whether the gland is used for general industrial work or needs hazard protection against high temperatures or explosions. The cables that fit into the glands are either armored or unarmored and a different type of gland will be required for each variety. The gland itself can be made of metals, such as brass or aluminum, or plastic; each material is useful in a different environment.

There are two major categories for cable glands: industrial and hazardous. An industrial cable gland is a general-use gland that meets general hazard requirements, so it is useful in environments without high temperatures or the risk of explosions. If the environment is hazardous, a hazardous gland is used, because these glands meet the necessary extra requirements. They are extra fortified, so they are resistant to temperatures and outside forces that general glands cannot withstand.

Polyamide Glands for Ex e Applications

4 joule

LYRA



Technical Details		
Material	Body, Cap PA 6 (Polyamide 6) Seal CR (Chloroprene), Silicone	
Ingress Protection Rating	IP 68 - 5 Bar, 30 min IP 66	
Operating Temperature	Seal Material	
	CR (Chloroprene)	
	Silicone	
Ex e/tb / Ex tb	-40°C to +80°C	
Ex-i	-40°C to +70°C	
Equipment For	<ul style="list-style-type: none"> Gas & Dust potentially explosive atmospheres. Cable glands should be also used for intrinsically safe circuits Ex-i. These cable glands shall have a light blue colored cap. The symbol "I" will be added beside of the "BM" for order processing. 	
Suitable for use in	Group II Gas Group IIC ZONE1/ZONE2 Group III Dust Group IIIC ZONE21/ZONE 22	
Equipment Marking	Ex II 2GD Ex eb IIC Gb Ex tb IIIC Db	
Marking Example *	BMD BM-X... CE 0722 Ⓢ 2GD Ex eb IIC Gb Ex tb IIIC Db IP66/68 Tc-40°C +80°C IMQ 13 ATEX 010X IECEx IMQ 13.0003X	
Impact Test Result	4J	
Thread Type	<ul style="list-style-type: none"> Metric (M) ISO Pitch 1,5 Npt (N) ANSI ASME B1.20.1 PG (P) DIN 40430 Other thread types also available upon request. 	
Cable Type	Non Armoured	
Accessories	<ul style="list-style-type: none"> Lock nuts Gaskets (Washers) Dome Plugs Dust Plugs Double Seals 	
Remarks	<ul style="list-style-type: none"> We recommend the use of locknuts and gaskets to ensure IP rating for rough surfaces or through holes. Accessories must be ordered separately. 	
Approvals	Certificate Number	Standards
	IMQ 13 ATEX 010X	EN 60079-0:2012 + A11:2013 EN 60079-7:2015 EN 60079-31:2014
	IECEx IMQ 13.0003X	IEC 60079-0:2011 Edition:6.0 IEC 60079-31:2013 Edition:2.0 IEC 60079-7:2016 Edition: 6.0
		ISO 4892-2
	№ TC RU C-TR.AA87.B.00941	ГОСТ 31610.0-2014 ГОСТ IEC 60079-1:2013 ГОСТ IEC 60079-31:2013
	DNV 12.0051 X	ABNT NBR IEC 60079-0:2013, ABNT NBR IEC 60079-7:2008 ABNT NBR IEC 60079-31:2011
	E-14045	IEC/EN60079-0, IEC/EN60079-7, IEC/EN60079-31 IEC/EN 62444

-For more information see our webpage.

* The standard marking consists ATEX & IECEx only. Marking acc. to other standards on request.



with Dust Plug & Gasket



with Dome Plug & Washer



Order Coding						
Part Number	Seal	-	Gasket (Washer)	Seal Type	Lock Nut	Sealing Plug
See table	Mandatory C Chloropren	-	Option WC Chloroprene WF Fiber WS Silicone	Option Double Seal	Option L Lock nut	Option P Dome Plug
*Part number for blue cap is BML-..						
Example						
BM-X3	C	-	WC	DS	L	P
*BML-X3						

LYRA

Polyamide Glands for Ex e Applications



Thread Type METRIC acc. to ISO 965 - 3

Outer Thread Size (Male)	Clamping Range Ø min - max mm	Outer Thread Length TL mm	Spanner Width		Outer Ø D mm	max. Height H mm	Part Number
			Cap SW Cap mm	Body SW Body mm			
M20x1,5	5,0 - 10,0	10,0	22	24	27,0	32,2	BM-SX2
	6,0 - 12,0	10,0	24	24	27,0	32,4	BM-X2
	6,0 - 12,0	15,0	24	24	27,0	32,4	BM-X2L
	10,0 - 14,0	10,0	27	27	30,9	31,9	BM-X3
	10,0 - 14,0	15,0	27	27	30,9	31,9	BM-X4
M25x1,5	10,0 - 14,0	10,0	27	27	30,9	31,9	BM-SX5
	10,0 - 14,0	15,0	27	27	30,9	31,9	BM-SX6
	11,0 - 17,0	10,0	29	29	32,5	37,7	BM-XEU25
	13,0 - 18,0	15,0	33	33	37,2	38,4	BM-X6
	13,0 - 18,0	10,0	33	33	37,2	38,4	BM-X5
M32x1,5	13,0 - 18,0	10,0	33	36	41,0	38,4	BM-SX7
	15,0 - 21,0	10,0	36	36	41,0	42,3	BM-XEU32
	18,0 - 25,0	15,0	42	42	47,1	43,3	BM-X7
M40x1,5	19,0 - 28,0	10,0	46	46	52,4	47,4	BM-XEU40
	19,0 - 28,0	15,0	46	46	52,4	47,4	BM-XEU40L
	22,0 - 32,0	18,0	53	53	59,6	52,4	BM-X8
M50x1,5	30,0 - 38,0	18,0	60	60	67,8	54,8	BM-X9
M63x1,5	34,0 - 44,0	18,0	65	65	72,4	54,9	BM-X10

Thread Type NPT acc. to ANSI B1.20.1

Outer Thread Size (Male)	Clamping Range Ø min-max mm	Outer Thread Length TL mm	Spanner Width		Outer Ø D mm	max. Height H mm	Part Number
			Cap SW Cap mm	Body SW Body mm			
NPT 1/2"	5,0 - 10,0	15	22	24	27,0	32,2	BN-SX2
	6,0 - 12,0	15	24	24	27,0	32,4	BN-X2
	10,0 - 14,0	15	27	27	30,9	31,9	BN-LX2
NPT 3/4"	13,0 - 18,0	15	33	33	37,2	38,4	BN-X3
NPT 1"	18,0 - 25,0	18	42	42	47,1	43,3	BN-X4

High Impact Polyamide Glands for Ex e Applications

7 joule

HI-LYRA



Technical Details	
Material	Body, Cap: PA 6 (Polyamide 6) Seal: CR (Chloroprene), Silicone
Ingress Protection Rating	IP 68 - 5 Bar, 30 min IP 66
Operating Temperature	Seal Material CR (Chloroprene) : -40°C to +70°C Silicone : -60°C to +70°C
Equipment For	<ul style="list-style-type: none"> Gas & Dust potentially explosive atmospheres. Cable glands should be also used for intrinsically safe circuits Ex-i. These cable glands shall have a light blue colored cap. The symbol "I" will be added beside of the "HIBM" for order processing.
Suitable for use in	Group II Gas Group IIC ZONE1/ZONE2 Group III Dust Group IIIC ZONE21/ZONE 22
Equipment Marking	Ex II 2GD Ex eb IIC Gb Ex tb IIIC Db
Marking Example *	BMD HIBM-X... CE 0722 II 2GD Ex eb IIC Gb Ex tb IIIC Db IP66/68 Ta-60°C to +70°C IMQ 13 ATEX 010X IECEx IMQ 13.0003X
Impact Test Result	7J
Thread Type	<ul style="list-style-type: none"> Metric (M) ISO Pitch 1,5 Npt (N) ANSI ASME B1.20.1 PG (P) DIN 40430 Other thread types also available upon request.
Cable Type	Non Armoured
Accessories	<ul style="list-style-type: none"> Lock nuts Gaskets (Washers) Dome Plugs Dust Plugs Double Seals
Remarks	<ul style="list-style-type: none"> We recommend the use of locknuts and gaskets to ensure IP rating for rough surfaces or through holes. Accessories must be ordered separately.

Approvals	Certificate Number	Standards
	IMQ 13 ATEX 010X	EN 60079-0:2012 + A11:2013 EN 60079-7:2015 EN 60079-31:2014
	IECEx IMQ 13.0003X	IEC 60079-0:2011 Edition:6.0 IEC 60079-31:2013 Edition:2.0 IEC 60079-7:2016 Edition: 6.0
		ISO 4892-2
	№ TC RU C-TR.AA87.B.00941	ГОСТ 31610.0-2014 ГОСТ IEC 60079-1:2013 ГОСТ IEC 60079-31:2013
	DNV 12.0051 X	ABNT NBR IEC 60079-0:2013, ABNT NBR IEC 60079-7:2008 ABNT NBR IEC 60079-31:2011
	E-14045	IEC/EN60079-0, IEC/EN60079-7, IEC/EN60079-31 IEC/EN 62444

-For more information see our webpage.
* The standard marking consists ATEX & IECEx only. Marking acc. to other standards on request.



Ex-e Gland Ex-i Gland with Lock Nut



with Dust Plug & Gasket with Dome Plug & Washer



Order Coding						
Part Number	Seal	- Gasket (Washer)	Seal Type	Lock Nut	Sealing Plug	
	Mandatory	- Option	Option	Option	Option	
See table	C Chloroprene S Silicone	- WC Chloroprene WS Silicone WF Fiber	DS Double Seal	L Lock nut	P Dome Plug	
*Part number for blue cap is HIBM-..						
Example						
HIBM-X2 *HIBM-X2	S	- WC	DS	L	P	

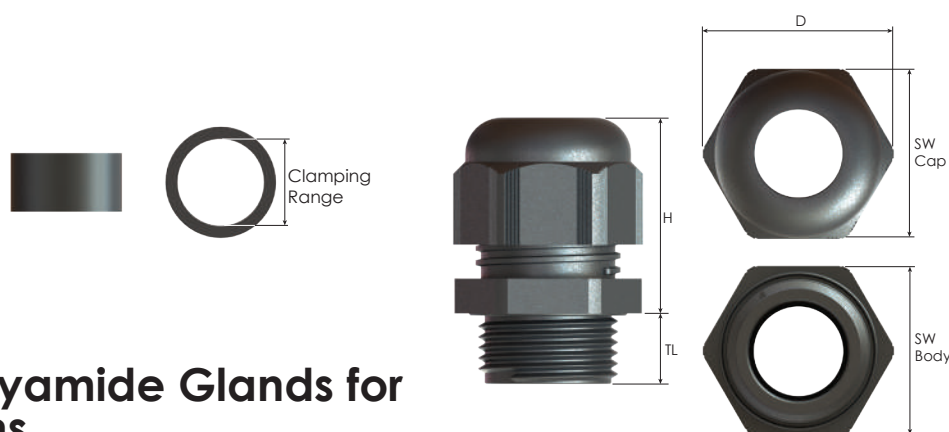

HI-LYRA

High Impact Polyamide Glands for Ex e Applications

Thread Type METRIC acc. to ISO 965-3								
Outer Thread Size (Male)	Clamping Range		Outer Thread Length	Spanner Width		Outer Ø	max. Height	Part Number
	Ø min-max mm	Seal Type		Cap	Body			
			TL mm	SW Cap mm	SW Body mm	D mm	H mm	
M12x1,5	4,0 - 6,5	Single	10,0	15	15	17,0	25,3	HIBM-0XS
	4,0 - 6,5	Single	15,0	15	15	17,0	25,3	HIBM-XS
M16x1,5	5,0 - 8,0	Single	10,0	19	19	21,7	27,4	HIBM-SX1
	5,0 - 8,0	Single	15,0	19	19	21,7	27,4	HIBM-SX1L
	6,0 - 10,0	Single	10,0	22	22	25,0	32,2	HIBM-X1
	6,0 - 10,0	Single	15,0	22	22	25,0	32,2	HIBM-X1L
M20x1,5	6,0 - 10,0	Single	10,0	22	24	27,0	32,2	HIBM-SX2
	7,0 - 12,0	Single	10,0	24	24	27,0	32,4	HIBM-X2
	7,0 - 12,0	Single	15,0	24	24	27,0	32,4	HIBM-X2L
	7,0 - 13,0	Single	10,0	25	25	27,5	34,0	HIBM-MX2
	11,0 - 14,0	Single	10,0	27	27	30,9	31,9	HIBM-X3
	11,0 - 14,0	Single	15,0	27	27	30,9	31,9	HIBM-X4
M25x1,5	11,0 - 14,0	Single	10,0	27	27	30,9	31,9	HIBM-SX5
	11,0 - 14,0	Single	15,0	27	27	30,9	31,9	HIBM-SX6
	14,0 - 18,0	Single	10,0	33	33	37,2	38,4	HIBM-X5
	14,0 - 18,0	Single	15,0	33	33	37,2	38,4	HIBM-X6
	12,0 - 17,0	Single	10,0	29	29	32,5	37,7	HIBM-XEU25
	12,0 - 17,0	Single	15,0	29	29	32,5	37,7	HIBM-XEU25L
M32x1,5	16,0 - 21,0	Single	10,0	36	36	41,0	42,3	HIBM-XEU32
	16,0 - 21,0	Single	15,0	36	36	41,0	42,3	HIBM-XEU32L
	14,0 - 18,0	Single	10,0	33	36	41,0	38,4	HIBM-SX7
	19,0 - 25,0	Single	15,0	42	42	47,1	43,3	HIBM-X7
M40x1,5	20,0 - 28,0	Single	10,0	46	46	52,4	47,4	HIBM-XEU40
	20,0 - 28,0	Single	15,0	46	46	52,4	47,4	HIBM-XEU40L
	23,0 - 32,0	Single	18,0	53	53	59,6	52,4	HIBM-X8
M50x1,5	31,0 - 38,0	Single	18,0	60	60	67,8	54,8	HIBM-X9
M63x1,5	35,0 - 44,0	Single	18,0	65	65	72,4	54,9	HIBM-X10

Thread Type NPT acc. to ANSI B1.20.1								
Outer Thread Size (Male)	Clamping Range		Outer Thread Length	Spanner Width		Outer Ø	max. Height	Part Number
	Ø min-max mm	Seal Type		Cap	Body			
			TL mm	SW Cap mm	SW Body mm	D mm	H mm	
NPT 3/8"	6,0 - 10,0	Single	15,0	22	22	25,0	32,2	HIBM-X1
NPT 1/2"	6,0 - 10,0	Single	15,0	22	24	27,0	32,2	HIBM-SX2
	7,0 - 12,0	Single	15,0	24	24	27,0	32,4	HIBM-X2
	11,0 - 14,0	Single	15,0	27	27	30,9	31,9	HIBM-LX2
NPT 3/4"	14,0 - 18,0	Single	15,0	33	33	37,2	38,4	HIBM-X3
NPT 1"	19,0 - 25,0	Single	18,0	42	42	47,1	43,3	HIBM-X4

High Impact Polyamide Glands for Ex e Applications

7 joule





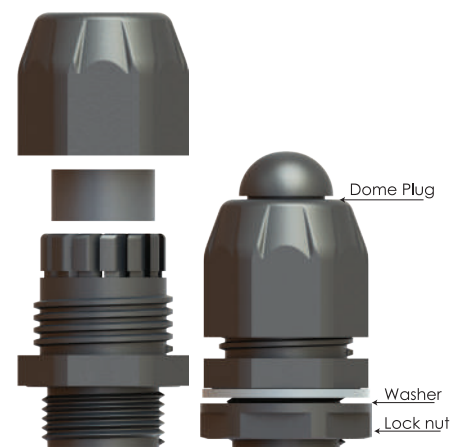

VEGA High Impact

Technical Details	
Material	Body, Cap Seal
	PA 6 (Polyamide 6) CR (Chloroprene), Silicone
Ingress Protection Rating	IP 68 - 5 Bar, 30 min IP 66
	Seal Material
Operating Temperature	CR (Chloroprene)
	Silicone
Ex e/tb / Ex tb / Ex-i	-40°C to +70°C -60°C to +70°C
Equipment For	• Gas & Dust potentially explosive atmospheres. • Cable glands should be also used for intrinsically safe circuits Ex-i. These cable glands shall have a light blue colored cap. The symbol "I" will be added beside of the "EHIBM" for order processing.
	Suitable for use in
Equipment Marking	Group II Gas Group IIC ZONE1/ZONE2 Group III Dust Group IIIC ZONE21/ZONE 22
	Ex II 2GD Ex eb IIC Gb Ex tb IIIC Db
Marking Example *	BMD EHIBM-X.. CE 0722  2GD Ex eb IIC Gb Ex tb IIIC Db Ta-40°C to +70°C IP66/68 IECEx IMQ 13.0003X IMQ 13 ATEX 010
Impact Test Result	7J
Thread Type	• Metric (M) ISO Pitch 1,5 • Other thread types also available upon request.
Cable Type	Non Armoured
Accessories	• Lock nuts • Gaskets (Washers) • Dome Plugs • Double Seals • Dust Plug
	Remarks
	• We recommend the use of locknuts and gaskets to ensure IP rating for rough surfaces or through holes. • Accessories must be ordered separately.



Option A



Approvals	Certificate Number	Standards
	IMQ 13 ATEX 010X	EN 60079-0:2012 + A11:2013 EN 60079-7:2015 EN 60079-31:2014
	IECEx IMQ 13.0003X	IEC 60079-0:2011 Edition:6.0 IEC 60079-31:2013 Edition:2.0 IEC 60079-7:2016 Edition: 6.0
		ISO 4892-2
	№ TC RU C-TR.AA87.B.00941	ГОСТ 31610.0-2014 ГОСТ IEC 60079-1:2013 ГОСТ IEC 60079-31:2013
	DNV 12.0051 X	ABNT NBR IEC 60079-0:2013, ABNT NBR IEC 60079-7:2008 ABNT NBR IEC 60079-31:2011
	E-14045	IEC/EN60079-0, IEC/EN60079-7, IEC/EN60079-31 IEC/EN 62444

-For more information see our webpage.
* The standard marking consists ATEX & IECEx only. Marking acc. to other standards on request.

Order Coding				
Part Number	Seal	Gasket (Washer)	Lock Nut	Sealing Plug
See table	Mandatory C Chloroprene S Silicone	- Option WC Chloroprene WF Fiber WS Silicone	Option L Lock nut	Option P Dome Plug
*Part number for blue cap is EHBMI-..				
Example				
EHIBM-X2L *EHIBM-X2L	C	- WC	L	P



VEGA

High Impact Polyamide Glands for Ex e Applications







Tread Type **METRIC** acc. to ISO 965 - 3

Outer Thread Size (Male)	Clamping Range		Outer Thread Length TL mm	Spanner Width		Outer Ø D mm	max. Height		Part Number
	Ø min - max mm	Seal Type		SW Cap mm	SW Body mm		H mm		
M12x1,5	3,0 - 6,5	Double	10,0	15	15	17,0	30,3		EHIBM-OXS(DS)
	3,0 - 6,5	Double	15,0	15	15	17,0	30,3		EHIBM-XS(DS)
	4,0 - 6,5	Single	10,0	15	15	17,0	30,3		EHIBM-OXS
	4,0 - 6,5	Single	15,0	15	15	17,0	30,3		EHIBM-XS
M16x1,5	4,0 - 8,0	Double	10,0	19	19	21,3	33,6		EHIBM-SX1(DS)
	4,0 - 8,0	Double	15,0	19	19	21,3	33,6		EHIBM-SX1L(DS)
	4,0 - 10,0	Double	10,0	22	22	25,0	37,2		EHIBM-X1(DS)
	4,0 - 10,0	Double	15,0	22	22	25,0	37,2		EHIBM-X1L(DS)
	5,0 - 8,0	Single	10,0	19	19	21,3	33,6		EHIBM-SX1
	5,0 - 8,0	Single	15,0	19	19	21,3	33,6		EHIBM-SX1L
	6,0 - 10,0	Single	10,0	22	22	25,0	37,2		EHIBM-X1
	6,0 - 10,0	Single	15,0	22	22	25,0	37,2		EHIBM-X1L
M20x1,5	4,0 - 10,0	Double	10,0	22	24	27,5	37,2		EHIBM-SX2(DS)
	4,0 - 13,0	Double	10,0	25	25	27,5	38,4		EHIBM-MX2(DS)
	6,0 - 10,0	Single	10,0	22	24	27,5	37,2		EHIBM-SX2
	6,0 - 12,0	Double	10,0	24	24	27,5	37,8		EHIBM-X2(DS)
	6,0 - 12,0	Double	15,0	24	24	27,5	37,8		EHIBM-X2L(DS)
	7,0 - 12,0	Single	10,0	24	24	27,5	37,8		EHIBM-X2
	7,0 - 12,0	Single	15,0	24	24	27,5	37,8		EHIBM-X2L
	7,0 - 13,0	Single	10,0	25	25	27,5	38,4		EHIBM-MX2
	8,0 - 14,0	Double	10,0	27	27	31,0	37,0		EHIBM-X3(DS)
	8,0 - 14,0	Double	15,0	27	27	31,0	37,0		EHIBM-X4(DS)
	11,0 - 14,0	Single	10,0	27	27	31,0	37,0		EHIBM-X3
	11,0 - 14,0	Single	15,0	27	27	31,0	37,0		EHIBM-X4
M25x1,5	8,0 - 14,0	Double	10,0	27	27	31,0	37,8		EHIBM-SX5(DS)
	8,0 - 14,0	Double	15,0	27	27	31,0	37,8		EHIBM-SX6(DS)
	9,0 - 17,0	Double	10,0	29	29	32,5	42,2		EHIBM-XEU25(DS)
	9,0 - 17,0	Double	15,0	29	29	32,5	42,2		EHIBM-XEU25L(DS)
	10,0 - 18,0	Double	10,0	33	33	37,0	43,6		EHIBM-X5(DS)
	10,0 - 18,0	Double	15,0	33	33	37,0	43,6		EHIBM-X6(DS)
	11,0 - 14,0	Single	10,0	27	27	31,0	37,8		EHIBM-SX5
	11,0 - 14,0	Single	15,0	27	27	31,0	37,8		EHIBM-SX6
	12,0 - 17,0	Single	10,0	29	29	32,5	42,2		EHIBM-XEU25
	12,0 - 17,0	Single	15,0	29	29	32,5	42,2		EHIBM-XEU25L
	14,0 - 18,0	Single	10,0	33	33	37,0	43,6		EHIBM-X5
	14,0 - 18,0	Single	15,0	33	33	37,0	43,6		EHIBM-X6
M32x1,5	10,0 - 18,0	Double	10,0	33	36	41,0	43,6		EHIBM-SX7(DS)
	12,0 - 21,0	Double	10,0	36	36	41,0	47,3		EHIBM-XEU32(DS)
	12,0 - 21,0	Double	15,0	36	36	41,0	47,3		EHIBM-XEU32L(DS)
	14,0 - 18,0	Single	10,0	33	36	41,0	43,6		EHIBM-SX7
	14,0 - 25,0	Double	15,0	42	42	47,5	48,7		EHIBM-X7(DS)
	16,0 - 21,0	Single	10,0	36	36	41,0	47,3		EHIBM-XEU32
	16,0 - 21,0	Single	15,0	36	36	41,0	47,3		EHIBM-XEU32L
	19,0 - 25,0	Single	15,0	42	42	47,5	48,7		EHIBM-X7
M40x1,5	17,0 - 28,0	Double	10,0	46	46	52,0	52,4		EHIBM-XEU40(DS)
	17,0 - 28,0	Double	15,0	46	46	52,0	52,4		EHIBM-XEU40L(DS)
	20,0 - 28,0	Single	10,0	46	46	52,0	52,4		EHIBM-XEU40
	20,0 - 28,0	Single	15,0	46	46	52,0	52,4		EHIBM-XEU40L
	21,0 - 32,0	Double	18,0	53	53	60,0	57,9		EHIBM-X8(DS)
	23,0 - 32,0	Single	18,0	53	53	60,0	57,9		EHIBM-X8
M50x1,5	22,0 - 38,0	Double	18,0	60	60	67,5	60,1		EHIBM-X9(DS)
	31,0 - 38,0	Single	18,0	60	60	67,5	60,1		EHIBM-X9
M63x1,5	28,0 - 44,0	Double	18,0	65	65	72,0	60,4		EHIBM-X10(DS)
	35,0 - 44,0	Single	18,0	65	65	72,0	60,4		EHIBM-X10

High Impact Polyamide Glands for Ex e Applications

7 joule

VEGA High Impact

Technical Details		
Material	Body, Cap Seal PA 6 (Polyamide 6) CR (Chloroprene), Silicone	
Ingress Protection Rating	IP 68 - 5 Bar, 30 min IP 66	
Operating Temperature	Seal Material CR (Chloroprene) -40°C to +70°C Silicone -60°C to +70°C	
Equipment For	<ul style="list-style-type: none"> Gas & Dust potentially explosive atmospheres. Cable glands should be also used for intrinsically safe circuits Ex-i. These cable glands shall have a light blue colored cap. The symbol "I" will be added beside of the "EHIBM" for order processing. 	
Suitable for use in	Group II Gas Group IIC ZONE1/ZONE2 Group III Dust Group IIIC ZONE21/ZONE 22	
Equipment Marking	Ex II 2GD Ex eb IIC Gb Ex tb IIIC Db	
Marking Example *	BMD EHIBM-X.. CE 0722  2GD Ex eb IIC Gb Ex tb IIIC Db T _a -40°C to +70°C IP66/68 IECEx IMQ 13.0003X IMQ 13 ATEX 010	
Impact Test Result	7J	
Thread Type	<ul style="list-style-type: none"> Metric (M) ISO Pitch 1,5 Other thread types also available upon request. 	
Cable Type	Non Armoured	
Accessories	<ul style="list-style-type: none"> Lock nuts Gaskets (Washers) Dome Plugs Double Seals Dust Plug 	
Remarks	<ul style="list-style-type: none"> We recommend the use of locknuts and gaskets to ensure IP rating for rough surfaces or through holes. Accessories must be ordered separately. 	
Approvals	Certificate Number	Standards
	IMQ 13 ATEX 010X	EN 60079-0:2012 + A11:2013 EN 60079-7:2015 EN 60079-31:2014
	IECEX IMQ 13.0003X	IEC 60079-0:2011 Edition:6.0 IEC 60079-31:2013 Edition:2.0 IEC 60079-7:2016 Edition: 6.0
		ISO 4892-2
	№ TC RU C-TR.AA87.B.00941	ГОСТ 31610.0-2014 ГОСТ IEC 60079-1:2013 ГОСТ IEC 60079-31:2013
	DNV 12.0051 X	ABNT NBR IEC 60079-0:2013, ABNT NBR IEC 60079-7:2008 ABNT NBR IEC 60079-31:2011
	E-14045	IEC/EN60079-0, IEC/EN60079-7, IEC/EN60079-31 IEC/EN 62444

-For more information see our webpage.

* The standard marking consists ATEX & IECEx only. Marking acc. to other standards on request.



Option A



Order Coding				
Part Number	Seal	Gasket (Washer)	Lock Nut	Sealing Plug
See table	Mandatory C Chloroprene S Silicone	- Option WC Chloroprene WF Fiber WS Silicone	Option L Lock nut	Option P Dome Plug
*Part number for blue cap is EHBMI-..				
Example				
EHIBM-X2L	C	- WC	L	P
*EHIBM-X2L				



VEGA

High Impact Polyamide Glands for Ex e Applications

Thread Type **NPT** acc. to ANSI B1.20.1

Outer Thread Size (Male)	Clamping Range		Outer Thread Length TL mm	Spanner Width		Outer Ø D mm	max. Height H mm	Part Number
	Ø min-max mm	Seal Type		SW Cap mm	SW Body mm			
NPT 3/8"	4,0 - 10,0	Double	15,0	22	22	25,0	37,2	EHIBN-X1(DS)
	6,0 - 10,0	Single	15,0	22	22	25,0	37,2	EHIBN-X1
NPT 1/2"	4,0 - 10,0	Double	15,0	22	24	27,5	37,2	EHIBN-SX2(DS)
	4,0 - 10,0	Single	15,0	22	24	27,5	37,2	EHIBN-SX2
	6,0 - 12,0	Double	15,0	24	24	27,5	37,8	EHIBN-X2(DS)
	7,0 - 12,0	Single	15,0	24	24	27,5	37,8	EHIBN-X2
	8,0 - 14,0	Double	15,0	27	27	31,0	37,0	EHIBN-LX2(DS)
11,0 - 14,0	Single	15,0	27	27	31,0	37,0	EHIBN-LX2	
NPT 3/4"	10,0 - 18,0	Double	15,0	33	33	37,0	43,6	EHIBN-X3(DS)
	14,0 - 18,0	Single	15,0	33	33	37,0	43,6	EHIBN-X3
NPT 1"	14,0 - 25,0	Double	18,0	42	42	47,5	48,7	EHIBN-X4(DS)
	19,0 - 25,0	Single	18,0	42	42	47,5	48,7	EHIBN-X4

bimed

CABLE GLANDS for NON-ARMOURED NON-CIRCULAR CABLES for Gas & Dust Application



Gemini
Hi-Gemini

262 - 263
264 - 265

Ex Glands / Group II-III / Gas & Dust







A cable gland is a fitting that connects a cable to an electrical source, and also is able to secure the cable so it will not escape. Cable gland units are placed into different categories, depending on whether the gland is used for general industrial work or needs hazard protection against high temperatures or explosions. The cables that fit into the glands are either armored or unarmored and a different type of gland will be required for each variety. The gland itself can be made of metals, such as brass or aluminum, or plastic; each material is useful in a different environment.

There are two major categories for cable glands: industrial and hazardous. An industrial cable gland is a general-use gland that meets general hazard requirements, so it is useful in environments without high temperatures or the risk of explosions. If the environment is hazardous, a hazardous gland is used, because these glands meet the necessary extra requirements. They are extra fortified, so they are resistant to temperatures and outside forces that general glands cannot withstand.

Polyamide Cable Glands for Ex e Applications and Heat Trace Cables

4joule

GEMINI

Technical Details		
Material	Body, Cap	PA 6 (Polyamide 6)
	Seal	CR (Chloroprene), Silicone
Ingress Protection Rating	IP 68 - 5 Bar, 30 min IP 66	
Operating Temperature	Seal Material	
	CR (Chloroprene)	Silicone
	Ex e/tb / Ex tb	-40°C to +80°C
Ex-i	-40°C to +70°C	-60°C to +70°C
Equipment For	<ul style="list-style-type: none"> Gas & Dust potentially explosive atmospheres. Cable glands should be also used for intrinsically safe circuits Ex-i. These cable glands shall have a light blue colored cap. The symbol "I" will be added beside of the "BM" for order processing. 	
Suitable for use in	Group II	Gas Group IIC ZONE1/ZONE2
	Group III	Dust Group IIIC ZONE21/ZONE 22
Equipment Marking	Ex II 2GD Ex eb IIC Gb Ex tb IIIC Db	
Marking Example *	BMD BM-X2L.. CE 0722  II 2GD Ex eb IIC Gb Ex tb IIIC Db IP66/68 Ta-40°C to +80°C IMQ 13 ATEX 011X IECEx IMQ 13.0004X	
Impact Test Result	4J	
Thread Type	<ul style="list-style-type: none"> Metric (M) ISO Pitch 1,5 Other thread types also available upon request. 	
Cable Type	Non Armoured, Non Circular, Heat Trace	
Accessories	<ul style="list-style-type: none"> Lock nuts Gaskets (Washers) Dust plugs 	
Remarks	<ul style="list-style-type: none"> We recommend the use of locknuts and gaskets to ensure IP rating for rough surfaces or through holes. Accessories must be ordered separately. 	
Approvals	Certificate Number	Standards
	IMQ 13 ATEX 011X	EN 60079-0:2009 EN 60079-7:2007 EN 60079-31:2009
	IECEx IMQ 13.0004X	IEC 60079-0:2007 Edition:5 IEC 60079-31:2008 Edition:1 IEC 60079-7:2006 Edition: 4
		ISO 4892-2
	№ TC RU C-TR.AA87.B.00941	ГОСТ 31610.0-2014 ГОСТ IEC 60079-1:2013 ГОСТ IEC 60079-31:2013
	DNV 12.0051 X	ABNT NBR IEC 60079-0:2013, ABNT NBR IEC 60079-7:2008 ABNT NBR IEC 60079-31:2011
	E-14045	IEC/EN60079-0, IEC/EN60079-7, IEC/EN60079-31 IEC/EN 62444
-For more information see our webpage.		
* The standard marking consists ATEX & IECEx only. Marking acc. to other standards on request.		

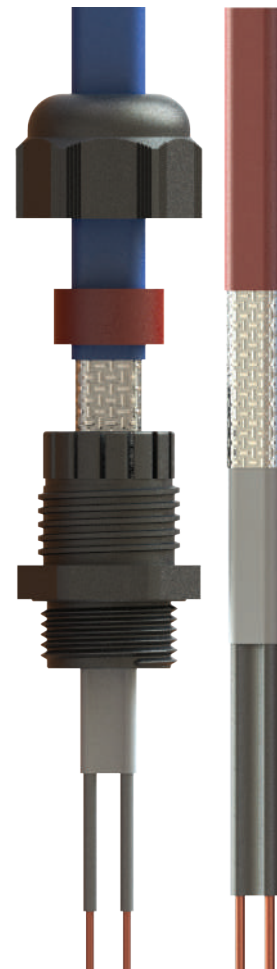

Order Coding			
Part Number	Seal	Gasket (Washer)	Lock Nut
Mandatory	Mandatory	- Option	Option
See table	C Chloroprene S Silicone	- WC Chloroprene WF Fiber WS Silicone	L Lock nut
*Part number for blue cap is BMI-..			
Example			
BM-X2L (10,8x6,0)	C	- WC	L
* BMI-X2L (10,8x6,0)			

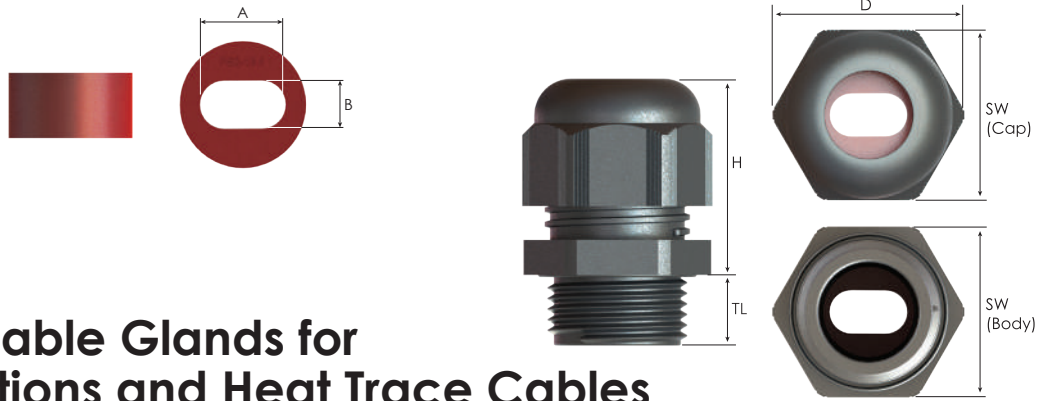

GEMINI

Polyamide Cable Glands for Ex e Applications and Heat Trace Cables







Tread Type **METRIC** acc. to ISO 965-3

Outer Thread Size (Male)	Flat Hole		Outer Thread Length	Spanner Width		Outer Ø	max. Height	Part Number
	Height	Width		Cap	Body			
	B	A	TL	SW Cap	SW Body	D	H	
	mm	mm	mm	mm	mm	mm	mm	
M20x1,5	4,0	10,0	10,0	24	24	27,0	32,4	BM-X2 (10,0x4,0)
	4,0	10,0	15,0	24	24	27,0	32,4	BM-X2L (10,0x4,0)
	5,0	12,8	10,0	27	27	30,9	31,9	BM-X3 (12,8x5,0)
	5,0	12,8	15,0	27	27	30,9	31,9	BM-X4 (12,8x5,0)
	6,0	10,8	10,0	24	24	27,0	32,4	BM-X2 (10,8x6,0)
	6,0	10,8	10,0	27	27	30,9	31,9	BM-X3 (10,8x6,0)
	6,0	10,8	15,0	24	24	27,0	32,4	BM-X2L (10,8x6,0)
	6,0	10,8	15,0	27	27	30,9	31,9	BM-X4 (10,8x6,0)
	6,5	11,0	15,0	24	24	27,0	32,4	BM-X2L (11,0x6,5)
	6,5	11,0	10,0	24	24	27,0	32,4	BM-X2 (11,0x6,5)
	6,5	12,4	10,0	27	27	30,9	31,9	BM-X3 (12,4x6,5)
	6,5	12,4	15,0	27	27	30,9	31,9	BM-X4 (12,4x6,5)
M25x1,5	4,0	10,0	10,0	24	27	30,9	32,4	BM-XSX5 (10,0x4,0)
	4,0	10,0	15,0	24	27	30,9	32,4	BM-XSX6 (10,0x4,0)
	5,0	12,8	10,0	27	27	30,9	31,9	BM-SX5 (12,8x5,0)
	5,0	12,8	15,0	27	27	30,9	31,9	BM-SX6 (12,8x5,0)
	5,0	15,0	10,0	33	33	37,2	38,4	BM-X5 (15,0x5,0)
	5,0	15,0	15,0	33	33	37,2	38,4	BM-X6 (15,0x5,0)
	6,0	10,8	10,0	24	27	30,9	32,4	BM-XSX5 (10,8x6,0)
	6,0	10,8	10,0	27	27	30,9	31,9	BM-SX5 (10,8x6,0)
	6,0	10,8	15,0	24	27	30,9	32,4	BM-XSX6 (10,8x6,0)
	6,0	10,8	15,0	27	27	30,9	31,9	BM-SX6 (10,8x6,0)
	6,0	12,0	15,0	33	33	37,2	38,4	BM-X6 (12,0x6,0)
	6,0	12,0	10,0	33	33	37,2	38,4	BM-X5 (12,0x6,0)
	6,5	11,0	10,0	24	27	30,9	32,4	BM-XSX5 (11,0x6,5)
	6,5	11,0	15,0	24	27	30,9	32,4	BM-XSX6 (11,0x6,5)
	6,5	12,4	10,0	27	27	30,9	31,9	BM-SX5 (12,4x6,5)
	6,5	12,4	15,0	27	27	30,9	31,9	BM-SX6 (12,4x6,5)
M32x1,5	5,0	15,0	10,0	33	36	41,0	38,4	BM-SX7 (15,0x5,0)
	6,0	12,0	10,0	33	36	41,0	38,4	BM-SX7 (12,0x6,0)

High Impact Polyamide Cable Glands for Ex e Applications and Heat Trace Cables

7 joule

HI-GEMINI

Technical Details	
Material	Body, Cap PA 6 (Polyamide 6) Seal CR (Chloroprene)
Ingress Protection Rating	IP 68 - 5 Bar, 30 min IP 66
Operating Temperature	Seal Material CR (Chloroprene) -40°C to +70°C Silicone -60°C to +70°C
Equipment For	<ul style="list-style-type: none"> Gas & Dust potentially explosive atmospheres. Cable glands should be also used for intrinsically safe circuits Ex-i. These cable glands shall have a light blue colored cap. The symbol "I" will be added beside of the "HIBM" for order processing.
Suitable for use in	Group II Gas Group IIC ZONE1/ZONE2 Group III Dust Group IIIC ZONE21/ZONE 22
Equipment Marking	Ex II 2GD Ex eb IIC Gb Ex tb IIIC Db
Marking Example *	BMD HIBM-X2.. CE 0722  II 2GD Ex eb IIC Gb Ex tb IIIC Db IP66/68 Ta-40°C to +80°C IECEx IMQ 13.0003X IMQ 13 ATEX 010
Impact Test Result	7J
Thread Type	<ul style="list-style-type: none"> Metric (M) ISO Pitch 1,5 Other thread types also available upon request.
Cable Type	Non armoured non circular heat trace
Accessories	<ul style="list-style-type: none"> Lock nuts Gaskets (Washers) Dust plugs
Remarks	<ul style="list-style-type: none"> We recommend the use of locknuts and gaskets to ensure IP rating for rough surfaces or through holes. Accessories must be ordered separately.
Approvals	Certificate Number Standards
	IMQ 13 ATEX 010X EN 60079-0:2012 + A11:2013 EN 60079-7:2015 EN 60079-31:2014
	IECEx IMQ 13.0003X IEC 60079-0:2011 Edition:6.0 IEC 60079-31:2013 Edition:2.0 IEC 60079-7:2016 Edition: 6.0
	ISO 4892-2
	№ TC RU C-TR.AA87.B.00941 GOCT 31610.0-2014 GOCT IEC 60079-1:2013 GOCT IEC 60079-31:2013
	DNV 12.0051 X ABNT NBR IEC 60079-0:2013, ABNT NBR IEC 60079-7:2008 ABNT NBR IEC 60079-31:2011
	E-14045 IEC/EN60079-0, IEC/EN60079-7, IEC/EN60079-31 IEC/EN 62444

-For more information see our webpage.

* The standard marking consists ATEX & IECEx only. Marking acc. to other standards on request.

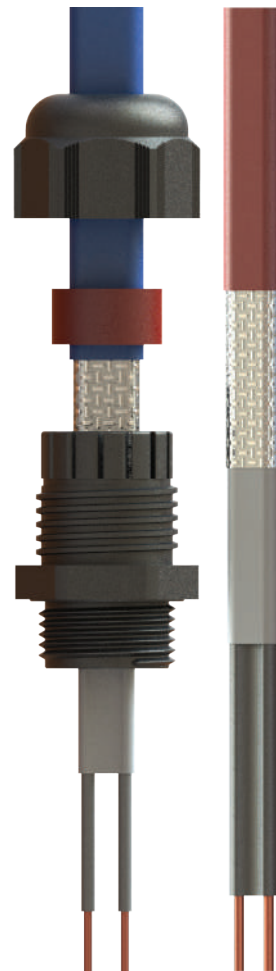

Order Coding			
Part Number	Seal	Gasket (Washer)	Lock Nut
Mandatory	Mandatory	- Option	Option
See table	C Chloroprene S Silicone	- WC Chloroprene WS Silicone	L Lock nut
*Part number for blue cap is HIBMI-...			
Example			
HIBM-X5 (10,8x6,0) * HIBM-X5 (10,8x6,0)	C	- WC	L

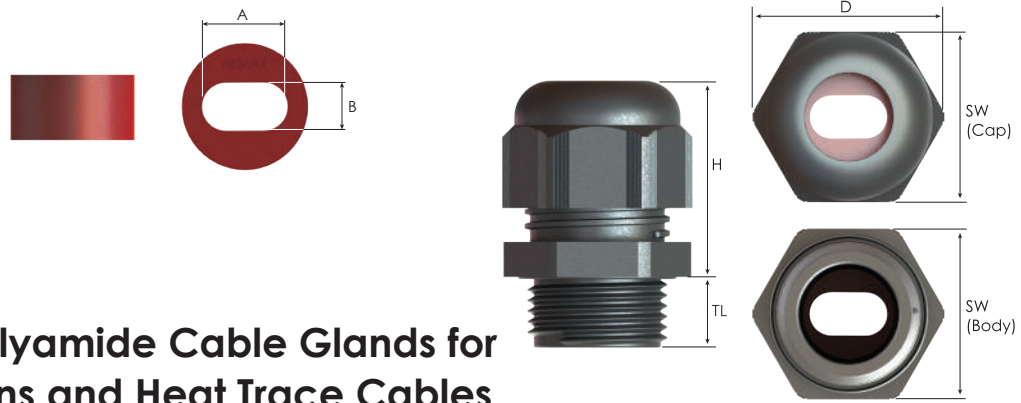

High Impact Polyamide Cable Glands for Ex e Applications and Heat Trace Cables

Thread Type **METRIC** acc. to ISO 965-3

Outer Thread Size (Male)	Flat Hole		Outer Thread Length	Spanner Width		Outer Ø	max. Height	Part Number
	Height	Width		Cap	Body			
	B mm	A mm	TL mm	SW Cap mm	SW Body mm	D mm	H mm	
M25x1,5	5,0	12,8	10,0	27	27	30,9	31,9	HIBM-SX5 (12,8x5,0)
	5,0	12,8	10,0	29	29	32,5	37,7	HIBM-XEU25 (12,8x5,0)
	5,0	12,8	10,0	33	33	37,2	38,4	HIBM-X5 (12,8x5,0)
	5,0	12,8	15,0	27	27	30,9	31,9	HIBM-SX6 (12,8x5,0)
	5,0	12,8	15,0	29	29	32,5	37,7	HIBM-XEU25L (12,8x5,0)
	5,0	12,8	15,0	33	33	37,2	38,4	HIBM-X6 (12,8x5,0)
	5,0	15,0	10,0	29	29	32,5	37,7	HIBM-XEU25 (15,0x5,0)
	5,0	15,0	10,0	33	33	37,2	38,4	HIBM-X5 (15,0x5,0)
	5,0	15,0	15,0	29	29	32,5	37,7	HIBM-XEU25L (15,0x5,0)
	5,0	15,0	15,0	33	33	37,2	38,4	HIBM-X6 (15,0x5,0)
	6,0	10,8	10,0	27	27	30,9	31,9	HIBM-SX5 (10,8x6,0)
	6,0	10,8	10,0	29	29	32,5	37,7	HIBM-XEU25 (10,8x6,0)
	6,0	10,8	10,0	33	33	37,2	38,4	HIBM-X5 (10,8x6,0)
	6,0	10,8	15,0	27	27	30,9	31,9	HIBM-SX6 (10,8x6,0)
	6,0	10,8	15,0	29	29	32,5	37,7	HIBM-XEU25L (10,8x6,0)
	6,0	10,8	15,0	33	33	37,2	38,4	HIBM-X6 (10,8x6,0)

bimed

PLUGS for Gas & Dust Applications



Draco
Hi-Draco

268 - 269
270 - 271

Ex Glands / Group II-III / Gas & Dust



Polyamide Hexagonal Plugs for Ex e Applications

4 joule

DRACO

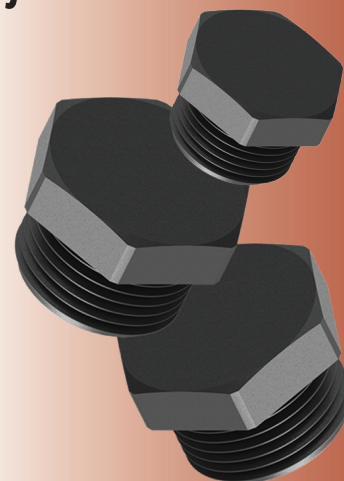

Technical Details		
Material	Body PA 6 (Polyamide 6) O-ring CR (Chloroprene) , Silicone	
Ingress Protection Rating	IP 68 - 5 Bar, 30 min IP 66	
Operating Temperature	O-ring Material CR (Chloroprene) Silicone	
Ex eb/tb / Ex tb	-40°C to +80°C -60°C to +80°C	
Ex i	-40°C to +70°C -60°C to +70°C	
Equipment For	<ul style="list-style-type: none"> Gas & Dust potentially explosive atmospheres. Cable glands should be also used for intrinsically safe circuits Ex-i. These cable glands shall have a light blue colored lock nut. The symbol "I" will be added beside of the "TP" for order processing. 	
Suitable for use in	Group II Gas Group IIC ZONE1/ZONE2 Group III Dust Group IIIC ZONE21/ZONE 22	
Equipment Marking	Ex II 2GD Ex eb IIC Gb / Ex tb IIIC Db	
Marking Example *	BMD TP-X... CE 0722 II 2GD Ex e IIC Gb Ex tb IIIC Db IP66/68 Ta -40°C to +80°C IMQ 13 ATEX 010X IECEx IMQ 13.0003X	
Impact Test Result	4J	
Thread Type	<ul style="list-style-type: none"> Metric (M) ISO Pitch 1,5 Npt (N) ANSI ASME B1.20.1 	
Accessories	<ul style="list-style-type: none"> Lock nuts Gaskets (Washers) 	
Remarks	<ul style="list-style-type: none"> We recommend the use of locknuts and gaskets to ensure IP rating for rough surfaces or through holes. Accessories must be ordered separately. 	
Approvals	Certificate Number	Standards
	IMQ 13 ATEX 010X	EN 60079-0:2012 + A11:2013 EN 60079-7:2015 EN 60079-31:2014
	IECEx IMQ 13.0003X	IEC 60079-0:2011 Edition:6 IEC 60079-31:2013 Edition:2 IEC 60079-7:2006 Edition: 4
		ISO 4892-2
	№ TC RU C-TR.AA87.B.00941	ГОСТ 31610.0-2014 ГОСТ IEC 60079-1:2013 ГОСТ IEC 60079-31:2013
	DNV 12.0051 X	ABNT NBR IEC 60079-0:2013 ABNT NBR IEC 60079-7:2008 ABNT NBR IEC 60079-31:2011
	E-14045	IEC/EN60079-0 IEC/EN60079-7 IEC/EN60079-31 IEC/EN 62444

-For more information see our webpage.
* The standard marking consists ATEX & IECEx only. Marking acc. to other standards on request.

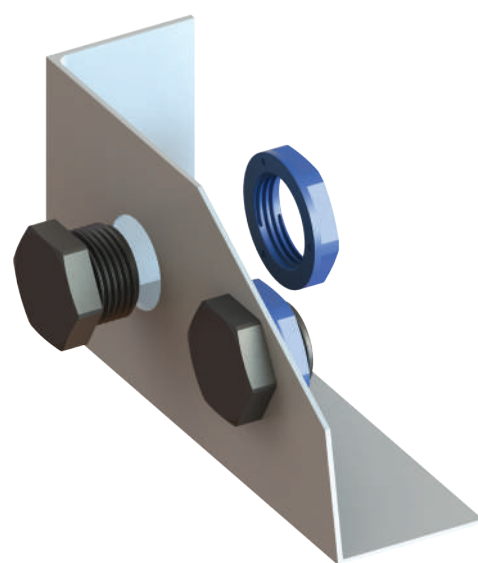

Order Coding		
Part Number	-	Gasket (Washer) Lock Nut
Mandatory	-	Option
See table	-	WC Chloroprene L Lock nut WF Fiber WS Silicone
*Part number for blue cap is TPI-..		
Example		
TP-X02	-	WC
*TPI-X02	-	L

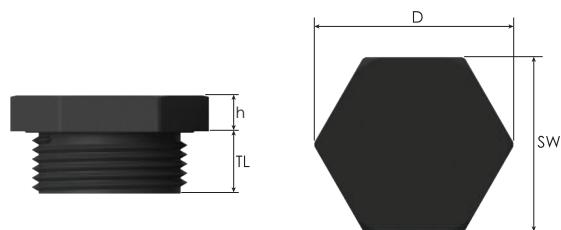

DRACO

Polyamide Hexagonal Plugs for Ex e Applications

Thread Type METRIC acc. to ISO 965-3					
Outer Thread Size (Male)	Outer Thread Length	Spanner Width	Outer Ø	Height	Part Number
	TL mm	SW mm	D mm	h mm	
M12x1,5	10,0	15	17,0	5,0	TP-X02
M16x1,5	11,0	19	22,0	4,3	TP-X01
M20x1,5	11,0	23	26,0	6,0	TP-X1
M25x1,5	10,0	28	32,0	5,8	TP-X2
M32x1,5	15,0	36	41,5	7,8	TP-X3
M40x1,5	18,0	46	53,0	8,5	TP-X4
M50x1,5	18,0	55	63,5	9,5	TP-X5
M63x1,5	18,0	69	79,5	9,5	TP-X6

See Example "A" for IP protection degree and clamping note:

The plugs Ex e II can be used with circuits Ex i. These cable glands should have a lock nut painted **light blue**. The plugs must be supplied with the flat washer for IP protection degree.

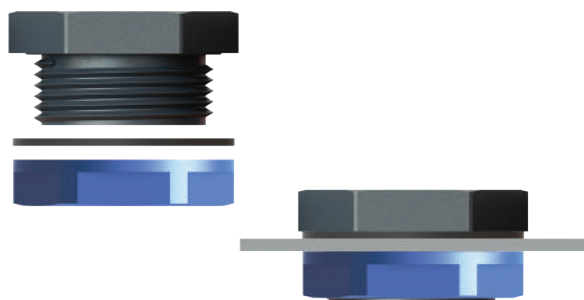

High Impact Hexagonal Plugs for Ex e Applications

7 joule

HI-DRACO

High Impact

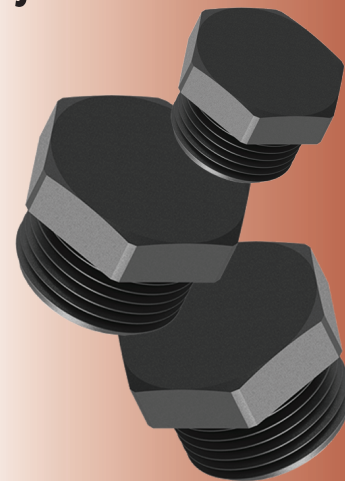

Technical Details		
Material	Body	PA 6 (Polyamide 6)
	O-ring	CR (Chloroprene), Silicone
Ingress Protection Rating	IP 68 - 5 Bar, 30 min IP 66	
Operating Temperature	O-ring Material	
	CR (Chloroprene)	Silicone
Ex eb/tb / Ex tb / Ex-i	-40°C to +70°C -60°C to +70°C	
Equipment For	<ul style="list-style-type: none"> Gas & Dust potentially explosive atmospheres. Cable glands should be also used for intrinsically safe circuits Ex-i. These cable glands shall have a light blue colored lock nut. The symbol "I" will be added beside of the "HITP" for order processing. 	
Suitable for use in	Group II	Gas Group IIC ZONE1/ZONE2
	Group III	Dust Group IIIC ZONE21/ZONE 22
Equipment Marking	Ex II 2GD Ex eb IIC Gb Ex tb IIIC Db	
Marking Example *	BMD HITP-X... CE 0722 II 2GD Ex eb IIC Gb Ex tb IIIC Db IP66/68 Ta -40°C to +70°C IMQ 13 ATEX 010X IECEx IMQ 13.0003X	
Impact Test Result	7J	
Thread Type	<ul style="list-style-type: none"> Metric (M) ISO Pitch 1,5 NPT (N) ANSI ASME B1.20.1 	
Accessories	<ul style="list-style-type: none"> Lock nuts Gaskets (Washers) 	
Remarks	<ul style="list-style-type: none"> We recommend the use of locknuts and gaskets to ensure IP rating for rough surfaces or through holes. Accessories must be ordered separately. 	
Approvals	Certificate Number	Standards
	IMQ 13 ATEX 010X	EN 60079-0:2012 + A11:2013 EN 60079-7:2015 EN 60079-31:2014
	IECEx IMQ 13.0003X	IEC 60079-0:2011 Edition:6 IEC 60079-31:2013 Edition:2 IEC 60079-7:2006 Edition: 4
		ISO 4892-2
	№ TC RU C-TR.AA87.B.00941	FOCT 31610.0-2014 FOCT IEC 60079-1:2013 FOCT IEC 60079-31:2013
	DNV 12.0051 X	ABNT NBR IEC 60079-0:2013 ABNT NBR IEC 60079-7:2008 ABNT NBR IEC 60079-31:2011
	E-14045	IEC/EN60079-0 IEC/EN60079-7 IEC/EN60079-31 IEC/EN 62444
-For more information see our webpage.		
* The standard marking consists ATEX & IECEx only. Marking acc. to other standards on request.		

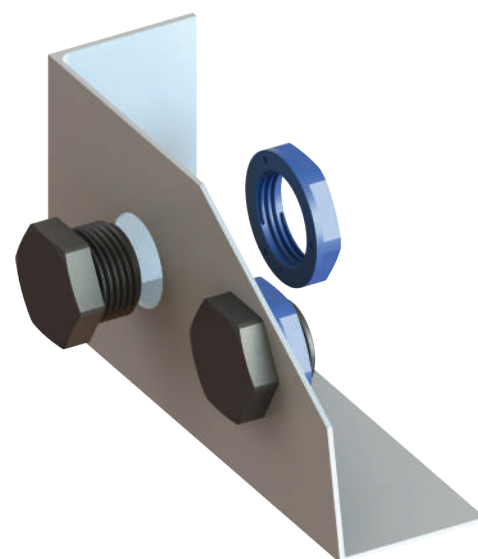

Order Coding			
Part Number	-	Gasket (Washer)	Lock Nut
Mandatory	-	Option	Option
See table	-	WC Chloroprene WF Fiber WS Silicone	L Lock nut
*Part number for blue cap is HITPI-...			
Example			
HITP-X02	-	WC	L
*HITPI-X02	-		

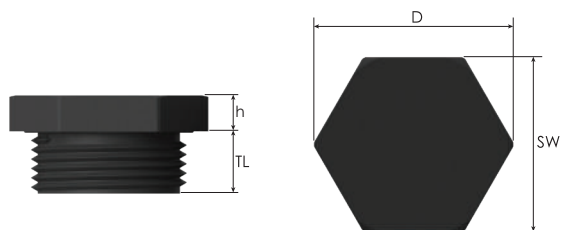

HI-DRACO

Polyamide High Impact Hexagonal Plugs for Ex e Applications

Thread Type METRIC acc. to ISO 965-3					
Outer Thread Size (Male)	Outer Thread Length	Spanner Width	Outer Ø	Height	Part Number
	TL mm				
M12x1,5	10,0	15	17,0	5,0	HITP-X02
M16x1,5	11,0	19	22,0	4,3	HITP-X01
	15,0	19	22,0	4,3	HITP-X01HL
M20x1,5	11,0	23	26,0	6,0	HITP-X1
	15,0	23	26,0	6,0	HITP-X1HL
M25x1,5	10,0	28	32,0	5,8	HITP-X2
	15,0	28	32,0	5,8	HITP-X2HL
M32x1,5	15,0	36	41,5	7,8	HITP-X3
M40x1,5	18,0	46	53,0	8,5	HITP-X4
M50x1,5	18,0	55	63,5	9,5	HITP-X5
M63x1,5	18,0	69	79,5	9,5	HITP-X6

Thread Type NPT acc. to ANSI ASME B1.20.1					
Outer Thread Size (Male)	Outer Thread Length	Spanner Width	Outer Ø	Height	Part Number
	TL mm				
NPT 1/2"	15,0	23	26,0	6,0	HITN-X1HL
NPT 3/4"	15,0	28	32,0	5,8	HITN-X2HL
NPT 1"	15,0	36	41,0	7,8	HITN-X3

See Example "A" for IP protection degree and clamping note:

The plugs Ex e II can be used with circuits Ex i. These cable glands should have a lock nut painted **light blue**. The plugs must be supplied with the flat washer for IP protection degree.

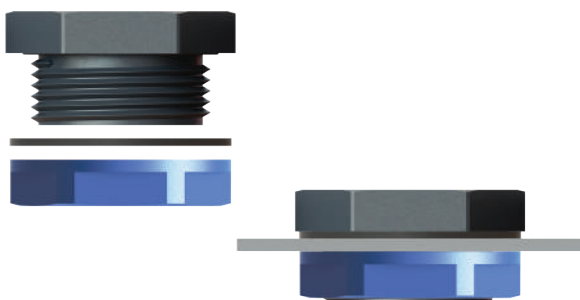

ACCESSORIES



Reducing Seals, Single, Rubber	274
Reducing Seals, Double, Rubber	275
Flat Cable Seals, Rubber	276
Dome Plugs for Industrial Applications	277
Multihole Seals	278 - 279
Cetus, Dome Plugs for Hazardous Applications	280 - 281
Gaskets (Washers)	282 - 283
Serrated Washers	284
Earth Tags	285
Lock Nuts, Flanged, Polyamide	286
Lock Nuts, Without Flange, Polyamide	287
Lock Nuts, Metal	288 - 289
Lock Nuts, EMC, Metal	290
Shrouds	291

ACCESSORIES



Reducing Seals Single, Rubber

Reducing seals, single

- For reducing the clamping ranges of cable glands.
- High quality strain relief and sealing, reliable performance for standard industrial applications.

Technical Details

Material	<ul style="list-style-type: none"> • CR (Chloroprene) • NBR • Silicone • EPDM
-----------------	---

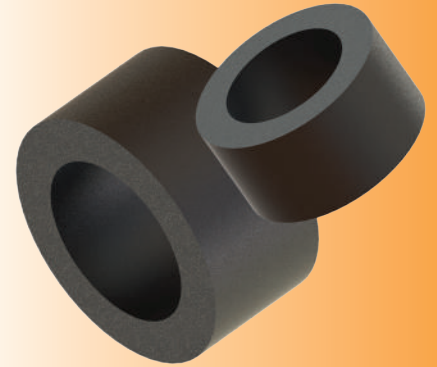
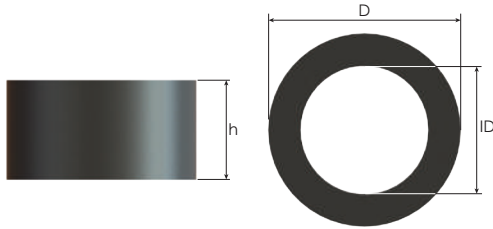

Reducing seals, single

Replaced Standard Seal Ø min-max mm	Clamping Range Reducing Seal Ø min-max mm	Inner Ø ID mm	Outer Ø D mm	Height h mm	Part Number				Minimum Order Quantity
					CR	NBR	Silicone	EPDM	
					black	black	red	black	
3,0 - 6,5	2,0 - 5,0	5,2	8,6	7,1	MS-05C	MS-05N	MS-05SR	MS-05E	500
4,0 - 8,0	2,0 - 6,0	6,3	10,9	7,0	MS-01C	MS-01N	MS-01SR	MS-01E	500
5,0 - 10,0	3,0 - 7,0	7,3	13,7	10,1	MS-01LC	MS-01LN	MS-01LSR	MS-01LE	500
6,0 - 12,0	5,0 - 9,0	9,4	16,0	8,4	MS-02C	MS-02N	MS-02SR	MS-02E	500
10,0 - 14,0	7,0 - 12,0	12,4	18,0	9,3	MS-02LC	MS-02LN	MS-02LSR	MS-02LE	500
11,0 - 17,0	9,0 - 13,0	13,5	20,4	10,7	MS-03LC	MS-03LN	MS-03LSR	MS-03LE	500
13,0 - 18,0	9,0 - 16,0	16,4	22,9	12,2	MS-03C	MS-03N	MS-03SR	MS-03E	500
15,0 - 21,0	11,0 - 15,0	15,5	25,4	14,2	MS-04LC	MS-04LN	MS-04LSR	MS-04LE	500
18,0 - 25,0	12,0 - 20,0	20,5	30,4	14,0	MS-04C	MS-04N	MS-04SR	MS-04E	500
19,0 - 28,0	16,0 - 23,0	23,5	33,40	17,0	MS-05LC	MS-05LN	MS-05LSR	MS-05LE	500
22,0 - 32,0	20,0 - 26,0	26,5	40,0	16,8	MS-05C	MS-05N	MS-05SR	MS-05E	500
30,0 - 38,0	25,0 - 31,0	31,5	45,0	16,5	MS-06C	MS-06N	MS-06SR	MS-06E	500
34,0 - 44,0	29,0 - 35,0	35,5	51,0	16,5	MS-07C	MS-07N	MS-07SR	MS-07E	500

Reducing Seals Double, Rubber



Reducing seals, Double

- For reducing the clamping ranges of cable glands.
- Double seal optimizes the range used.
- Special design for high quality strain relief and sealing, reliable performance for standard industrial applications.

Technical Details

Material	• CR (Chloroprene)
	• NBR
	• Silicone
	• EPDM

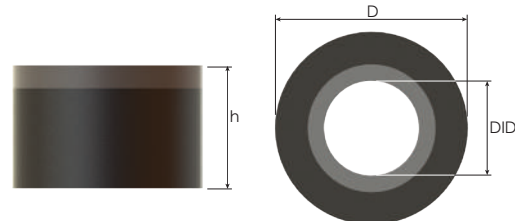

Bottom View

Reducing seals, double MDS (For Metal Glands)

Replaced Standard Seal		Clamping Range		Outer Ø	Inner Ø	Height	Part Number				Minimum Order Quantity
#1	#2	Double Seal	Outer Seal				CR	NBR	Silicone	EPDM	
Ø min-max mm	Ø min-max mm	Ø min-max mm	Ø min-max mm	D mm	ID mm	h mm	black	black	red	black	
3,0 - 6,5	2,0 - 5,0	2,0 - 4,0	3,0 - 6,5	8,6	4,2	9,1	MDS-05C	MDS-05N	MDS-05SR	MDS-05E	500
4,0 - 8,0	2,0 - 6,0	3,0 - 5,0	4,0 - 8,0	10,7	5,2	9,0	MDS-01C	MDS-01N	MDS-01SR	MDS-01E	500
5,0 - 10,0	3,0 - 7,0	3,0 - 7,0	5,0 - 10,0	13,7	7,2	12,4	MDS-01LC	MDS-01LN	MDS-01LSR	MDS-01LE	500
7,0 - 13,0	-	3,0 - 7,0	7,0 - 13,0	16,7	7,3	9,4	MDS-02SC	MDS-02SN	MDS-02SSR	MDS-02SE	500
6,0 - 12,0	5,0 - 9,0	5,0 - 8,5	6,0 - 12,0	16,0	8,7	10,4	MDS-02C	MDS-02N	MDS-02SR	MDS-02E	500
10,0 - 14,0	7,0 - 12,0	7,0 - 12,0	10,0 - 14,0	18,0	11,3	11,3	MDS-02LC	MDS-02LN	MDS-02LSR	MDS-02LE	500
11,0 - 17,0	9,0 - 13,0	8,0 - 13,0	11,0 - 17,0	20,4	13,2	11,5	MDS-03LC	MDS-03LN	MDS-03LSR	MDS-03LE	500
13,0 - 18,0	9,0 - 16,0	9,0 - 14,0	13,0 - 18,0	22,9	14,2	14,7	MDS-03C	MDS-03N	MDS-03SR	MDS-03E	500
15,0 - 21,0	11,0 - 15,0	11,0 - 16,0	15,0 - 21,0	25,2	16,3	16,7	MDS-04LC	MDS-04LN	MDS-04LSR	MDS-04LE	500
18,0 - 25,0	12,0 - 20,0	13,0 - 20,0	18,0 - 25,0	30,5	20,5	16,5	MDS-04C	MDS-04N	MDS-04SR	MDS-04E	500
19,0 - 28,0	16,0 - 23,0	16,0 - 21,0	19,0 - 28,0	33,2	21,3	19,5	MDS-05LC	MDS-05LN	MDS-05LSR	MDS-05LE	500
22,0 - 32,0	20,0 - 26,0	20,0 - 26,0	22,0 - 32,0	40,0	26,5	19,3	MDS-05C	MDS-05N	MDS-05SR	MDS-05E	500
30,0 - 38,0	25,0 - 31,0	21,0 - 31,0	30,0 - 38,0	46,0	31,4	19,5	MDS-06C	MDS-06N	MDS-06SR	MDS-06E	500
34,0 - 44,0	29,0 - 35,0	27,0 - 35,0	34,0 - 44,0	51,0	35,4	19,5	MDS-07C	MDS-07N	MDS-07SR	MDS-07E	500

Reducing seals, double PDS (For Plastic Glands)

Replaced Standard Seal		Clamping Range		Outer Ø	Inner Ø	Height	Part Number				Minimum Order Quantity
#1	#2	Double Seal	Outer Seal				CR	NBR	Silicone	EPDM	
Ø min-max mm	Ø min-max mm	Ø min-max mm	Ø min-max mm	D mm	ID mm	h mm	black	black	red	black	
3,0 - 6,5	2,0 - 5,0	2,0 - 3,0	3,0 - 6,5	8,6	4,2	8,1	PDS-05C	PDS-05N	PDS-05SR	PDS-05E	500
4,0 - 8,0	2,0 - 6,0	3,0 - 4,0	4,0 - 8,0	10,7	5,2	8,0	PDS-01C	PDS-01N	PDS-01SR	PDS-01E	500
5,0 - 10,0	3,0 - 7,0	3,0 - 5,0	5,0 - 10,0	13,7	7,2	11,4	PDS-01LC	PDS-01LN	PDS-01LSR	PDS-01LE	500
7,0 - 13,0	-	3,0 - 7,0	7,0 - 13,0	16,7	7,3	9,4	PDS-02SC	PDS-02SN	PDS-02SR	PDS-02SE	500
6,0 - 12,0	5,0 - 9,0	5,0 - 6,0	6,0 - 12,0	16,0	8,7	9,4	PDS-02C	PDS-02N	PDS-02SR	PDS-02E	500
10,0 - 14,0	7,0 - 12,0	7,0 - 10,0	10,0 - 14,0	18,0	11,3	10,3	PDS-02LC	PDS-02LN	PDS-02LSR	PDS-02LE	500
11,0 - 17,0	9,0 - 13,0	8,0 - 11,0	11,0 - 17,0	20,4	13,2	11,7	PDS-03LC	PDS-03LN	PDS-03LSR	PDS-03LE	500
13,0 - 18,0	9,0 - 16,0	9,0 - 13,0	13,0 - 18,0	22,9	14,2	13,2	PDS-03C	PDS-03N	PDS-03SR	PDS-03E	500
15,0 - 21,0	11,0 - 15,0	11,0 - 15,0	15,0 - 21,0	25,2	16,3	15,2	PDS-04LC	PDS-04LN	PDS-04LSR	PDS-04LE	500
18,0 - 25,0	12,0 - 20,0	13,0 - 18,0	18,0 - 25,0	30,5	20,5	15,0	PDS-04C	PDS-04N	PDS-04SR	PDS-04E	500
19,0 - 28,0	16,0 - 23,0	16,0 - 19,0	19,0 - 28,0	33,2	21,3	18,0	PDS-05LC	PDS-05LN	PDS-05LSR	PDS-05LE	500
22,0 - 32,0	20,0 - 26,0	20,0 - 22,0	22,0 - 32,0	40,0	26,5	17,8	PDS-05C	PDS-05N	PDS-05SR	PDS-05E	500
30,0 - 38,0	25,0 - 31,0	21,0 - 30,0	30,0 - 38,0	46,0	31,4	17,5	PDS-06C	PDS-06N	PDS-06SR	PDS-06E	500
34,0 - 44,0	29,0 - 35,0	27,0 - 34,0	34,0 - 44,0	51,0	35,4	17,5	PDS-07C	PDS-07N	PDS-07SR	PDS-07E	500

Flat Cable Seals Rubber

Flat cable seals

- To modify the clamping range to the shape of flat cables.
- High quality strain relief and sealing, reliable performance for standard industrial applications.

Technical Details

Material	<ul style="list-style-type: none"> • CR (Chloroprene) • NBR • Silicone • EPDM
-----------------	---

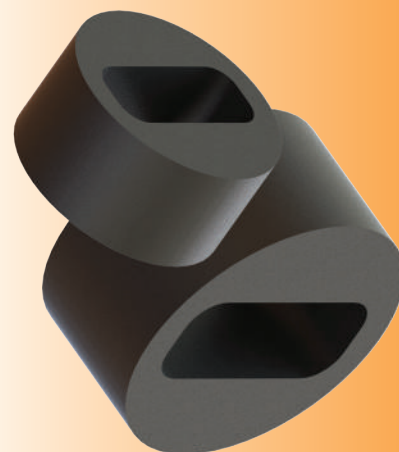
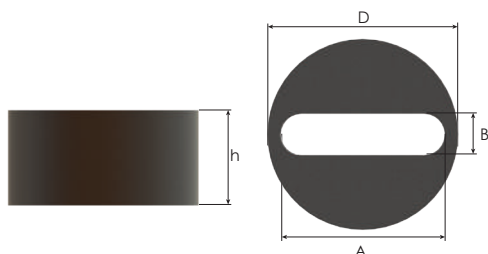

Flat Cable Seals

Replaced Standard Seal		Flat Hole		Outer Ø D mm	Height h mm	Part Number				Minimum Order Quantity
Seal min-max mm	Seal 2 min-max mm	Height B mm	Width A mm			CR black	NBR black	Silicone red	EPDM black	
3,0 - 6,5	2,0 - 5,0	3,0	5,0	8,6	7,1	MFS-01AC	MFS-01AN	-	MFS-01AE	500
		4,0	10,0	16,0	8,1	-	-	MFS-02ASR	-	500
6,0 - 12,0	5,0 - 9,0	6,5	11,0	16,0	8,1	-	-	MFS-02BSR	-	500
		6,0	10,8	16,0	8,1	-	-	MFS-02DSR	-	500
		6,0	10,8	18,0	9,3	-	-	MFS-03ASR	-	500
10,0 - 14,0	7,0 - 12,0	6,5	12,4	18,0	9,3	-	-	MFS-03BSR	-	500
		5,0	12,8	18,0	9,3	-	-	MFS-03CSR	-	500
		5,0	11,5	18,0	9,3	-	-	MFS-03DSR	-	500
11,0 - 17,0	9,0 - 13,0	2x5,3	10,1	20,4	9,5	MFS-04DC	MFS-04DN	-	MFS-04DE	500
		5,0	12,8	22,9	12,2	-	-	MFS-04ASR	-	500
13,0 - 18,0	9,0 - 16,0	5,0	10,0	22,9	12,2	-	-	MFS-04BSR	-	500
		6,0	10,8	22,9	12,2	-	-	MFS-04CSR	-	500
		6,0	12,0	22,9	12,2	-	-	MFS-04ESR	-	500
		5,0	15,0	22,9	12,2	-	-	MFS-04FSR	-	500
		5,8	18,0	22,9	12,2	MFS-04GC	MFS-04GN	-	MFS-04GE	500
18,0 - 25,0	12,0 - 20,0	5,8	19,0	30,4	14,0	MFS-05CC	MFS-05CN	-	MFS-05CE	500
		7,8	22,0	30,4	14,0	MFS-05DC	MFS-05DN	-	MFS-05DE	500

Dome Plugs for Industrial Applications

Plugs for sealing cable insert

- For standard industrial applications.
- Sealing of cable glands when no cable is used.

Technical Details

Material	PA 6 (Polyamide 6)	
Flammability	V2 acc. to UL94	
Operating Temperature	Permanent	Intermittent
	-20 °C to +100 °C	-30 °C to +150 °C

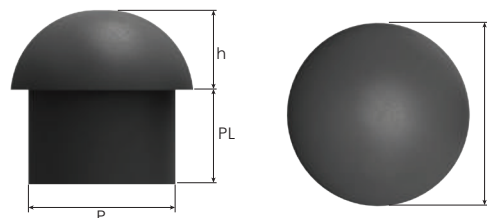

Dome Plugs

Size	Plug		Outer Ø D mm	Height h mm	Dome Plug Fit Into Clamping Range Ø min-max				Part Number			Minimum Order Quantity	
	Ø P mm	Length PL mm			Standard Seal mm	Reducing Seal mm	Double Seal mm	Outer Seal mm	RAL 7035	RAI 7001	RAL 9005		
									light grey	grey	black		
9	4,0	12,0	9,2	4,0	-	2,0 - 5,0	2,0 - 6,5	-	-	BDP-09-11	BDP-09-01	BDP-09-21	1000
	6,4	12,0	9,2	4,0	3,0 - 6,5	-	-	3,0 - 6,5	-	BDP-09-12	BDP-09-02	BDP-09-22	1000
11	5,0	14,0	10,5	5,0	-	2,0 - 6,0	3,0 - 8,0	-	-	BDP-11-11	BDP-11-01	BDP-11-21	1000
	8,0	13,7	10,5	4,7	4,0 - 8,0	-	-	4,0 - 8,0	-	BDP-11-12	BDP-11-02	BDP-11-22	1000
13	7,0	15,0	13,3	5,7	-	3,0 - 7,0	3,0 - 10,0	-	-	BDP-13-11	BDP-13-01	BDP-13-21	1000
	9,7	9,0	13,3	5,3	5,0 - 10,0	-	-	5,0 - 10,0	-	BDP-13-12	BDP-13-02	BDP-13-22	1000
13	9,7	15,0	13,3	5,7	5,0 - 10,0	-	-	5,0 - 10,0	-	BDP-13-12S	BDP-13-02S	BDP-13-22S	1000
	7,0	14,0	15,8	7,5	-	-	3,0 - 13,0	-	-	BDP-16-10	BDP-16-00	BDP-16-20	1000
16	8,5	13,0	15,8	7,7	-	5,0 - 9,0	5,0 - 12,0	-	-	BDP-16-11	BDP-16-01	BDP-16-21	1000
	12,0	13,0	15,8	8,0	6,0 - 12,0	-	-	6,0 - 12,0	-	BDP-16-12	BDP-16-02	BDP-16-22	1000
16	13,0	14,0	15,8	7,5	7,0 - 13,0	-	-	7,0 - 13,0	-	BDP-16-13	BDP-16-03	BDP-16-23	1000
	11,0	13,5	18,0	8,5	-	7,0 - 12,0	7,0 - 14,0	-	-	BDP-18-11	BDP-18-01	BDP-18-21	1000
18	13,6	13,5	18,0	8,7	10,0 - 14,0	-	-	10,0 - 14,0	-	BDP-18-12	BDP-18-02	BDP-18-22	1000
	13,0	14,5	20,0	7,0	-	9,0 - 13,0	8,0 - 17,0	-	-	BDP-20-11	BDP-20-01	BDP-20-21	1000
20	16,4	14,5	19,9	7,3	11,0 - 17,0	-	-	11,0 - 17,0	-	BDP-20-12	BDP-20-02	BDP-20-22	1000
	14,0	14,0	22,0	9,5	-	11,0 - 15,0	9,0 - 18,0	-	-	BDP-22-11	BDP-22-01	BDP-22-21	1000
22	17,8	14,0	22,0	10	13,0 - 18,0	-	-	13,0 - 18,0	-	BDP-22-12	BDP-22-02	BDP-22-22	1000
	16,1	15,5	24,0	9,0	-	9,0 - 16,0	11,0 - 21,0	-	-	BDP-24-11	BDP-24-01	BDP-24-21	1000
24	20,4	15,5	24,1	9,2	15,0 - 21,0	-	-	15,0 - 21,0	-	BDP-24-12	BDP-24-02	BDP-24-22	1000
	19,7	15,0	28,5	9,7	-	12,0 - 20,0	13,0 - 25,0	-	-	BDP-29-11	BDP-29-01	BDP-29-21	1000
29	25,0	15,0	28,5	9,7	18,0 - 25,0	-	-	18,0 - 25,0	-	BDP-29-12	BDP-29-02	BDP-29-22	1000
	20,5	15,8	31,5	9,2	-	16,0 - 23,0	16,0 - 28,0	-	-	BDP-32-11	BDP-32-01	BDP-32-21	1000
32	27,3	15,8	31,5	9,2	19,0 - 28,0	-	-	19,0 - 28,0	-	BDP-32-12	BDP-32-02	BDP-32-22	1000
	25,7	17,0	36,8	10,7	-	20,0 - 26,0	20,0 - 32,0	-	-	BDP-37-11	BDP-37-01	BDP-37-21	1000
37	31,8	17,0	36,8	10,7	22,0 - 32,0	-	-	19,0 - 28,0	-	BDP-37-12	BDP-37-02	BDP-37-22	1000
	30,6	20,2	43,3	11,9	-	25,0 - 31,0	21,0 - 38,0	-	-	BDP-45-11	BDP-45-01	BDP-45-21	1000
45	38,0	20,2	43,3	11,9	30,0 - 38,0	-	-	30,0 - 38,0	-	BDP-45-12	BDP-45-02	BDP-45-22	1000
	34,6	22,5	51,0	16,0	-	29,0 - 35,0	27,0 - 44,0	-	-	BDP-52-11	BDP-52-01	BDP-52-21	1000
52	44,2	22,5	51,0	16,0	34,0 - 44,0	-	-	34,0 - 44,0	-	BDP-52-12	BDP-52-02	BDP-52-22	1000

Multihole Seals

Multihole seals

- To use a number of small cables in one cable gland.
- High quality strain relief and sealing, reliable performance for standard industrial applications.

Technical Details

Material	<ul style="list-style-type: none"> • CR (Chloroprene) • NBR • Silicone • EPDM
-----------------	---

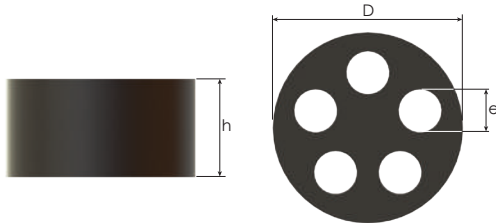

Multihole Seals

Replaced Standard Seal #1 Ø min-max mm	Standard Seal #2 Ø min-max mm	No. of Cores n	Core Ø e mm	Outer Ø D mm	Height h mm	Part Number				Minimum Order Quantity
						CR	NBR	Silicone	EPDM	
						black	black	red	black	
4,0 - 8,0	2,0 - 6,0	2	3,0	10,9	7,0	MMS-012C	MMS-012N	-	MMS-012E	500
			4,0			MMS-011C	MMS-011N	MMS-011SR	MMS-011E	500
		4	3,0			MMS-013C	MMS-013N	MMS-013SR	MMS-013E	500
5,0 - 10,0	3,0 - 7,0	2	3,0	13,7	10,4	MMS-017C	MMS-017N	-	MMS-017E	500
			4,0			MMS-014C	MMS-014N	-	MMS-014E	500
		4,5	MMS-015C			MMS-015N	MMS-015SR	MMS-015E	500	
		5,0	MMS-018C			MMS-018N	-	MMS-018E	500	
		4,0	MMS-019C			MMS-019N	-	MMS-019E	500	
		3	4,0			MMS-021C	MMS-021N	-	MMS-021E	500
6,0 - 12,0	5,0 - 9,0	2	1x4,7-1x6,6	16,0	8,0	MMS-02M1C	MMS-02M1N	-	MMS-02M1E	500
			5,0			MMS-025C	MMS-025N	-	MMS-025E	500
		6,0	MMS-021C			MMS-021N	-	MMS-021E	500	
		4,0	MMS-022C			MMS-022N	-	MMS-022E	500	
		5,0	MMS-023C			MMS-023N	-	MMS-023E	500	
		4	3,0			MMS-024C	MMS-024N	-	MMS-024E	500
10,0 - 14,0	7,0 - 12,0	2	4,0	18,0	9,3	MMS-026C	MMS-026N	-	MMS-026E	500
			6,0			MMS-02LC	MMS-02LN	-	MMS-02LE	500
		6,5	MMS-02AC			MMS-02AN	-	MMS-02AE	500	
		7,0	MMS-02CC			MMS-02CN	-	MMS-02CE	500	
		3	2x7,0-1x4,0			MMS-02GC	MMS-02GN	-	MMS-02GE	500
		4,0	MMS-02HC			MMS-02HN	-	MMS-02HE	500	
		5,6	MMS-029C			MMS-029N	-	MMS-029E	500	
		6,0	MMS-02JC			MMS-02JN	-	MMS-02JE	500	
		4	5,0			MMS-02DC	MMS-02DN	-	MMS-02DE	500
		6,0	MMS-02BC			MMS-02BN	-	MMS-02BE	500	
		5	6,0			MMS-02KC	MMS-02KN	-	MMS-02KE	500
		6	4,0			MMS-02EC	MMS-02EN	-	MMS-02EE	500
		6	4,0			MMS-02MC	MMS-02MN	-	MMS-02ME	500
		11,0 - 17,0	9,0 - 13,0			2	6,0	20,4	10,7	MMS-03CC
5,0	MMS-03EC			MMS-03EN	-		MMS-03EE			500
3	6,0			MMS-03DC	MMS-03DN	-	MMS-03DE			500
7,0	MMS-03FC			MMS-03FN	-	MMS-03FE	500			
4	5,0			MMS-03GC	MMS-03GN	-	MMS-03GE			500
5	4,0			MMS-03HC	MMS-03HN	-	MMS-03HE			500
6	4,0			MMS-03IC	MMS-03IN	-	MMS-03IE			500
7	3,0			MMS-03JC	MMS-03JN	-	MMS-03JE			500
13,0 - 18,0	9,0 - 16,0	2	6,6	22,9	12,2	MMS-032C	MMS-032N	-	MMS-032E	500
			7,0			MMS-033C	MMS-033N	-	MMS-033E	500
		8,0	MMS-034C			MMS-034N	-	MMS-034E	500	
		9,0	MMS-035C			MMS-035N	-	MMS-035E	500	
		3	6,6			MMS-036AC	MMS-036AN	-	MMS-036AE	500
		7,0	MMS-03BC			MMS-03BN	-	MMS-03BE	500	
		8,0	MMS-037C			MMS-037N	-	MMS-037E	500	
		4	6,6			MMS-039C	MMS-039N	-	MMS-039E	500
		7,0	MMS-039AC			MMS-039AN	-	MMS-039AE	500	
		8	4x2,0-2x4,0-2x6,0			MMS-039DC	MMS-039DN	-	MMS-039DE	500

Multihole Seals



Multihole seals

- To use a number of small cables in one cable gland.
- High quality strain relief and sealing, reliable performance for standard industrial applications.

Technical Details

Material	• CR (Chloroprene)
	• NBR
	• Silicone
	• EPDM

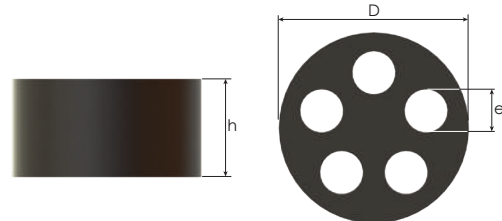

Replaced Standard Seal		No. of Cores	Core Ø	Outer Ø	Height	Part Number				Minimum Order Quantity
#1 Ø min-max mm	#2 Ø min-max mm					n	e mm	D mm	h mm	
15,0 - 21,0	11,0 - 15,0	2	7,0	25,4	14,2	MMS-04CC	MMS-04CN	-	MMS-04CE	500
			8,0			MMS-04AC	MMS-04AN	MMS-04ASR	MMS-04AE	500
			9,0			MMS-04DC	MMS-04DN	-	MMS-04DE	500
		3	8,0			MMS-04BC	MMS-04BN	-	MMS-04BE	500
			2x9,0-1x6,2			MMS-043AC	MMS-043AN	-	MMS-043AE	500
			6,0			MMS-04HC	MMS-04HN	-	MMS-04HE	500
		4	7,0			MMS-04IC	MMS-04IN	-	MMS-04IE	500
			8,0			MMS-04EC	MMS-04EN	MMS-04ESR	MMS-04EE	500
			6,0			MMS-04FC	MMS-04FN	-	MMS-04FE	500
		5	5,0			MMS-04JC	MMS-04JN	-	MMS-04JE	500
			6,0			MMS-04KC	MMS-04KN	-	MMS-04KE	500
			4,0			MMS-04MC	MMS-04MN	-	MMS-04ME	500
			5,0			MMS-04NC	MMS-04NN	-	MMS-04NE	500
			3,0			MMS-04LC	MMS-04LN	-	MMS-04LE	500
			4,0			MMS-04OC	MMS-04ON	-	MMS-04OE	500
			6			8,0	MMS-041C	MMS-041N	-	MMS-041E
9,0	MMS-042C			MMS-042N	-	MMS-042E	500			
7,5	MMS-043C	MMS-043N		-	MMS-043E	500				
8,0	MMS-045C	MMS-045N		-	MMS-045E	500				
8,5	MMS-046C	MMS-046N		-	MMS-046E	500				
3x4,9-2x4,2	MMS-046AC	MMS-046AN		-	MMS-046AE	500				
5,0	MMS-049C	MMS-049N		-	MMS-049E	500				
6,0	MMS-047C	MMS-047N		-	MMS-047E	500				
18,0 - 25,0	12,0 - 20,0	3	7,5	30,4	14,0	MMS-048C	MMS-048N	-	MMS-048E	500
			8,0			MMS-051C	MMS-051N	-	MMS-051E	500
			10,0			MMS-052C	MMS-052N	-	MMS-052E	500
		4	8,0			MMS-052AC	MMS-052AN	-	MMS-052AE	500
			8,0			MMS-053C	MMS-053N	-	MMS-053E	500
			9,0			MMS-054C	MMS-054N	-	MMS-054E	500
		5	8,0			MMS-055C	MMS-055N	-	MMS-055E	500
			7,0			MMS-056C	MMS-056N	-	MMS-056E	500
			6,0			MMS-057C	MMS-057N	-	MMS-057E	500
		6	7,0			MMS-058C	MMS-058N	-	MMS-058E	500
			6,0			MMS-059BC	MMS-059BN	-	MMS-059BE	500
			5,3			MMS-060AC	MMS-060AN	-	MMS-060AE	500
9,0	MMS-071C		MMS-071N	-	MMS-071E	500				
8,0	MMS-072C		MMS-072N	-	MMS-072E	500				
8,0	MMS-082C		MMS-082N	-	MMS-082E	500				
19,0 - 28,0	16,0 - 23,0	2	10,0	33,4	17,0	MMS-082AC	MMS-082AN	-	MMS-082AE	500
			8,0			MMS-083C	MMS-083N	-	MMS-083E	500
22,0 - 32,0	20,0 - 26,0	5	9,0	40,0	16,8	MMS-083AC	MMS-083AN	-	MMS-083AE	500
			8,0			MMS-082C	MMS-082N	-	MMS-082E	500
30,0 - 38,0	25,0 - 31,0	9	6x3,4-2x6,9-1x8,3	45,0	16,5	MMS-082C	MMS-082N	-	MMS-082E	500
			6x3,6-1x7,9-1x7,2-1x9,2			MMS-082AC	MMS-082AN	-	MMS-082AE	500
			1x7,1-4x6,2-5x5,2-1x10,8			MMS-083C	MMS-083N	-	MMS-083E	500
11	5x6,0-5x5,0-1x10,5	MMS-083AC	MMS-083AN	-	MMS-083AE	500				

Dome Plugs for Hazardous Applications

Technical Details	
Material	PA 6 (Polyamide 6)
Ingress Protection Rating	IP 68 - 5 Bar, 30 min IP 66
Equipment For	• Gas & Dust potentially explosive atmospheres.
Suitable for use in	Group II Gas Group IIC ZONE1/ZONE2 Group III Dust Group IIIC ZONE21/ZONE 22
Marking Example	
Gland Marking for	Octans BMD EBU.. CE 0722 II 2GD Ex d IIC Gb Ex e IIC Gb Ex tb IIIC Db Ta-40°C +80°C IP66/68 IECEx CES 13.0006X CESI 13 ATEX 018X
	Vela BMD EBS.. CE 0722 II 2GD Ex d IIC Gb Ex e IIC Gb Ex tb IIIC Db Ta-40°C +80°C IP66/68 IECEx CES 13.0006X CESI 13 ATEX 018X
	Lyra BMD BM-X. CE 0722 II 2GD Ex e IIC Gb Ex tb IIIC Db Ta-40°C +80°C IP66/68 IP66/68 IECEx IMQ 13.0003X IMQ 13 ATEX 010X
	Hi-Lyra BMD HIBM-X.. CE 0722 II 2GD Ex e IIC Gb Ex tb IIIC Db Ta-40°C +70°C IP66/68 IECEx IMQ 13.0003X IMQ 13 ATEX 010X
	Vega BMD EHIBM-X.. CE 0722 II 2GD Ex e IIC Gb Ex tb IIIC Db Ta-40°C +70°C IP66/68 IECEx IMQ 13.0003X IMQ 13 ATEX 010X
Impact Test Result	7J
Remarks	• For standard Ex-Proof applications.



Approvals	Octans and Vela		Lyra, Hi-Lyra and Vega	
	Certificate Number	Standards	Certificate Number	Standards
	IMQ 13 ATEX 018X	EN 60079-0:2012 EN 60079-7:2007 EN 60079-31:2014 EN 60079-1:2007	IMQ 13 ATEX 010X	EN 60079-0:2012 + A11:2013 EN 60079-7:2015 EN 60079-31:2014
	IECEx IMQ 13.0006X	IEC 60079-0:2011 Edition:6 IEC 60079-7:2006 Edition:4 IEC 60079-31:2013 Edition:2 IEC 60079-1:2014 Edition:7	IECEx IMQ 13.0003X	IEC 60079-0:2011 Edition:6.0 IEC 60079-31:2013 Edition:2.0 IEC 60079-7:2016 Edition: 6.0
	20150501-E474828	UL 2225, CAN/CSA-C22.2 No. 60079-0:11 CAN/CSA C22.2 No. 60079-7:12 CAN/CSA-C22.2 No. 60079-31:12		ISO 4892-2
	№ TC RU C-TR.Г505.В.00840	ГОСТ IEC 60079-1:2011 ГОСТ P МЭК 60079-0:2011 ГОСТ P МЭК 60079-7:2012 ГОСТ P МЭК 60079-31:2010 ГОСТ P МЭК 60079-14:2008	№ TC RU C-TR.Г505.В.00840	ГОСТ IEC 60079-1:2011 ГОСТ P МЭК 60079-0:2011 ГОСТ P МЭК 60079-7:2012 ГОСТ P МЭК 60079-31:2010 ГОСТ P МЭК 60079-14:2008
	DNV 12.0052 X	ABNT NBR IEC 60079-0:2013, ABNT NBR IEC 60079-1:2009, ABNT NBR IEC 60079-7:2008 e ABNT NBR IEC 60079-31:2011	DNV 12.0051 X	ABNT NBR IEC 60079-0:2013, ABNT NBR IEC 60079-7:2008 ABNT NBR IEC 60079-31:2011
	E-14044	IEC/EN60079-0, IEC/EN60079-7, IEC/EN60079-31 IEC/EN60079-1, IEC/EN 62444	E-14045	IEC/EN60079-0, IEC/EN60079-7, IEC/EN60079-31 IEC/EN 62444

-For more information see our webpage.



Dome Plugs for Hazardous Applications

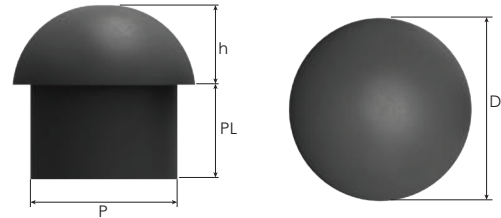

Dome plugs for Metal Glands (Octans & Vela)

Size	Plug		Dome Ø	Height	Dome Plug Fit Into Clamping Range Ø min-max		Part Number	Minimum Order Quantity
	Ø	Length			Octans	Vela		
	P mm	PL mm	D mm	h mm	Standard Seal mm	Standard Seal mm	RAL 9005 black	
15	5,8	10,0	15,0	4,0	3,0 - 6,0 / 4,0 - 6,0	4,0 - 6,0	BDPX-15-21	1000
22	11,8	15,0	21,5	6,0	10,0 - 12,0	10,0 - 12,0	BDPX-22-20	1000
28	16,8	17,0	27,5	8,0	14,0 - 17,0	14,0 - 17,0	BDPX-28-21	1000
36	23,8	20,0	36,0	10,0	22,0 - 24,0	22,0 - 24,0	BDPX-36-21	1000
40	27,8	24,0	40,0	10,0	26,0 - 28,0	26,0 - 28,0	BDPX-40-21	1000
50	37,8	24,0	50,0	12,0	35,0 - 38,0	35,0 - 38,0	BDPX-50-21	1000
63	47,8	26,0	63,0	14,0	46,0 - 48,0	-	BDPX-63-21	1000

*Only for Octans and Vela.

Dome plugs for Polyamide Glands (Lyra & Hi-Lyra & Vega)

Size	Plug		Dome Ø	Height	Dome Plug Fit Into Clamping Range Ø min-max				Part Number	Minimum Order Quantity
	Ø	Length			Lyra	Hi-Lyra & Vega	Hi-Lyra (DS) & Vega (DS)			
	P mm	PL mm	D mm	h mm	Standard Seal mm	Standard Seal mm	Outer Seal mm	Double Seal mm	RAL 9005 black	
9	4,0	12,0	9,2	4,0	-	-	-	3,0 - 6,5	BDPX-09-21	1000
	6,4	12,0	9,2	4,0	-	4,0 - 6,5	4,0 - 6,5	-	BDPX-09-22	1000
11	5,0	14,0	10,5	5,0	-	-	-	4,0 - 8,0	BDPX-11-21	1000
	8,0	13,7	10,5	4,7	-	5,0 - 8,0	5,0 - 8,0	-	BDPX-11-22	1000
13	7,0	15,0	13,3	5,7	-	-	-	4,0 - 10,0	BDPX-13-21	1000
	9,7	9,0	13,3	5,3	5,0 - 10,0	6,0 - 10,0	6,0 - 10,0	-	BDPX-13-22*	1000
	9,7	15,0	13,3	5,7	5,0 - 10,0	6,0 - 10,0	6,0 - 10,0	-	BDPX-13-22S	1000
16	7,0	14,0	15,8	7,5	-	-	-	4,0 - 13,0	BDPX-16-20	1000
	8,5	13,0	15,8	7,7	-	-	-	6,0 - 12,0	BDPX-16-21	1000
	12,0	13,0	15,8	8,0	6,0 - 12,0	7,0 - 12,0	7,5 - 12,0	-	BDPX-16-22	1000
	13,0	14,0	15,8	7,5	-	7,0 - 13,0	7,0 - 13,0	-	BDPX-16-23	1000
18	11,0	13,5	18,0	8,5	-	-	-	8,0 - 14,0	BDPX-18-21	1000
	13,6	13,5	18,0	8,7	10,0 - 14,0	11,0 - 14,0	11,0 - 14,0	-	BDPX-18-22	1000
20	13,0	14,5	20,0	7,0	-	-	-	9,0 - 17,0	BDPX-20-21	1000
	16,4	14,5	19,9	7,3	11,0 - 17,0	12,0 - 17,0	13,0 - 17,0	-	BDPX-20-22	1000
22	14,0	14,0	22,0	9,5	-	-	-	10,0 - 18,0	BDPX-22-21	1000
	17,8	14,0	22,0	10	13,0 - 18,0	14,0 - 18,0	13,0 - 18,0	-	BDPX-22-22	1000
24	16,1	15,5	24,0	9,0	-	-	-	12,0 - 21,0	BDPX-24-21	1000
	20,4	15,5	24,1	9,2	15,0 - 21,0	16,0 - 21,0	16,0 - 21,0	-	BDPX-24-22	1000
29	19,7	15,0	28,5	9,7	-	-	-	14,0 - 25,0	BDPX-29-21	1000
	25,0	15,0	28,5	9,7	18,0 - 25,0	19,0 - 25,0	20,0 - 25,0	-	BDPX-29-22	1000
32	20,5	15,8	31,5	9,2	-	-	-	17,0 - 28,0	BDPX-32-21	1000
	27,3	15,8	31,5	9,2	19,0 - 28,0	20,0 - 28,0	21,0 - 28,0	-	BDPX-32-22	1000
37	25,7	17,0	36,8	10,7	-	-	-	21,0 - 32,0	BDPX-37-21	1000
	31,8	17,0	36,8	10,7	22,0 - 32,0	23,0 - 32,0	25,0 - 32,0	-	BDPX-37-22	1000
45	30,6	20,2	43,3	11,9	-	-	-	22,0 - 38,0	BDPX-45-21	1000
	38,0	20,2	43,3	11,9	30,0 - 38,0	31,0 - 38,0	31,0 - 38,0	-	BDPX-45-22	1000
52	34,6	22,5	51,0	16,0	-	-	-	28,0 - 44,0	BDPX-52-21	1000
	44,2	22,5	51,0	16,0	34,0 - 44,0	35,0 - 44,0	35,0 - 44,0	-	BDPX-52-22	1000

*Only for Lyra, Hi-Lyra and Vega.

Gaskets (Washers)

Gaskets

- To ensure IP rating for rough surfaces or through holes.

Technical Details

Material

- CR (Chloroprene)
- NBR
- Silicone
- Polyamide 6
- Fibre

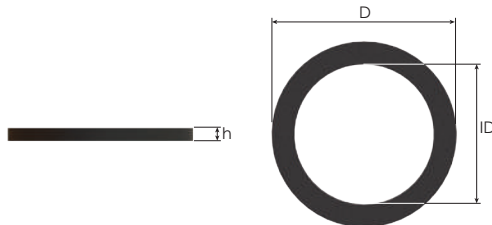

Gaskets (Washers) for Metric Size

For Thread Size Metric	Outer Ø D mm	Inner Ø ID mm	Height h mm	CR	NBR	Part Number Silicone	Polyamide	Fibre	Minimum Order Quantity
				black	black	red	white	green	
				BMSW-21C	BMSW-21N	BMSW-21SR	-	-	
M12	15,5	10,3	1,5	BMSW-21C	BMSW-21N	BMSW-21SR	-	-	20000
	15,5	12,1	1,5	-	-	-	BMSW-1PA	BMSW-1FB	20000
M16	21,5	14,3	1,5	BMSW-22C	BMSW-22N	BMSW-22SR	-	-	20000
	19,6	16,1	1,5	-	-	-	BMSW-2PA	BMSW-2FB	20000
M20	26,0	18,5	1,5	BMSW-23C	BMSW-23N	BMSW-23SR	-	-	20000
	23,8	20,1	1,5	-	-	-	BMSW-3PA	BMSW-3FB	20000
M25	31,5	23,3	1,5	BMSW-24C	BMSW-24N	BMSW-24SR	-	-	20000
	32,2	25,1	1,5	-	-	-	BMSW-4PA	BMSW-4FB	20000
M32	38,5	30,5	1,5	BMSW-25C	BMSW-25N	BMSW-25SR	-	-	10000
	39,8	32,1	1,5	-	-	-	BMSW-5PA	BMSW-5FB	10000
M40	48,5	38,5	1,5	BMSW-26C	BMSW-26N	BMSW-26SR	-	-	5000
	49,6	40,1	1,5	-	-	-	BMSW-6PA	BMSW-6FB	5000
M50	58,0	48,0	1,5	BMSW-27C	BMSW-27N	BMSW-27SR	-	-	5000
	62,0	50,2	1,5	-	-	-	BMSW-7PA	BMSW-7FB	5000
M60	68,0	58,0	1,5	BMSW-28SC	BMSW-28SN	BMSW-28SSR	-	-	5000
	72,0	60,2	1,5	-	-	-	BMSW-60PA	BMSW-60FB	5000
M63	70,0	61,2	1,5	BMSW-28C	BMSW-28N	BMSW-28SR	-	-	5000
	78,4	63,2	1,5	-	-	-	BMSW-8PA	BMSW-8FB	5000
M70	83,0	68,0	1,5	BMSW-29SC	BMSW-29SN	BMSW-29SSR	-	-	5000
	82,0	70,2	1,5	-	-	-	BMSW-70PA	BMSW-70FB	5000
M75	88,0	72,5	1,5	BMSW-29C	BMSW-29N	BMSW-29SR	-	-	5000
	93,4	75,2	1,5	-	-	-	BMSW-9PA	BMSW-9FB	3000
M80	92,0	78,0	1,5	BMSW-29LC	BMSW-29LN	BMSW-29LSR	-	-	3000
	98,0	80,2	1,5	-	-	-	BMSW-80PA	BMSW-80FB	3000
M85	97,0	83,0	1,5	BMSW-30SC	BMSW-30SN	BMSW-30SSR	-	-	3000
	103,0	85,2	1,5	-	-	-	BMSW-85PA	BMSW-85FB	3000
M90	102,0	88,0	1,5	BMSW-30C	BMSW-30N	BMSW-30SR	-	-	2000
	112,0	90,2	1,5	-	-	-	BMSW-10PA	BMSW-10FB	2000
M100	112,0	98,0	1,5	BMSW-31SC	BMSW-31SN	BMSW-31SSR	-	-	2000
	124,5	100,2	1,5	-	-	-	BMSW-11PA	BMSW-11FB	2000
M110	122,0	108,0	1,5	BMSW-31C	BMSW-31N	BMSW-31SR	-	-	1000
	134,0	110,2	2,0	-	-	-	BMSW-12PA	BMSW-12FB	1000
M115	127,0	113,0	1,5	BMSW-31LC	BMSW-31LN	BMSW-31LSR	-	-	1000
	139,0	115,2	2,0	-	-	-	BMSW-13PA	BMSW-13FB	1000
M130	142,0	128,0	1,5	BMSW-33C	BMSW-33N	BMSW-33SR	-	-	1000
	154,0	130,2	2,0	-	-	-	BMSW-14PA	BMSW-14FB	1000

Gaskets (Washers)



Gaskets

- To ensure IP rating for rough surfaces or through holes.

Technical Details

Material

- CR (Chloroprene)
- NBR
- Silicone
- Polyamide 6
- Fibre

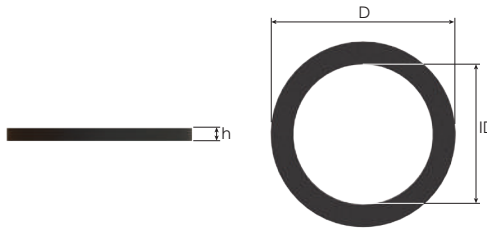

Gaskets (Washers) for NPT and G Size

For Thread Size NPT	Outer Ø D mm	Inner Ø ID mm	Height h mm	CR	NBR	Part Number Silicone	Polyamide	Fibre	Minimum Order Quantity
				black	black	red	white	green	
NPT 1/4"	16,8	11,7	2,0	BFSW-05C	BFSW-05N	BFSW-05SR	-	-	20000
	17,5	13,8	1,5	-	-	-	BNSW-1PA	BNSW-1FB	20000
NPT 3/8"	24,0	16,4	2,0	BFSW-01C	BFSW-01N	BFSW-01SR	-	-	20000
	21,0	17,5	1,5	-	-	-	BNSW-2PA	BNSW-2FB	20000
NPT 1/2"	29,0	20,4	2,0	BFSW-02C	BFSW-02N	BFSW-02SR	-	-	20000
	25,0	21,5	1,5	-	-	-	BNSW-3PA	BNSW-3FB	20000
NPT 3/4"	37,0	26,0	2,0	BFSW-03C	BFSW-03N	BFSW-03SR	-	-	20000
	33,0	26,8	1,5	-	-	-	BNSW-4PA	BNSW-4FB	20000
NPT 1"	45,0	32,6	2,0	BFSW-04C	BFSW-04N	BFSW-04SR	-	-	10000
	40,5	33,5	1,5	-	-	-	BNSW-5PA	BNSW-5FB	10000
NPT 1 1/4"	53,0	41,4	2,0	BFSW-05C	BFSW-05N	BFSW-05SR	-	-	5000
	50,0	42,3	1,5	-	-	-	BNSW-6PA	BNSW-6FB	5000
NPT 1 1/2"	61,0	47,2	2,0	BFSW-06C	BFSW-06N	BFSW-06SR	-	-	5000
	60,0	48,4	1,5	-	-	-	BNSW-7PA	BNSW-7FB	5000
NPT 2"	75,0	59,0	2,0	BFSW-07C	BFSW-07N	BFSW-07SR	-	-	5000
	78,4	60,5	1,5	-	-	-	BNSW-8PA	BNSW-8FB	5000
NPT 2 1/2"	85,0	73,2	1,5	-	-	-	BNSW-9PA	BNSW-9FB	5000
	-	-	-	-	-	-	BNSW-10PA	BNSW-10FB	5000
NPT 3"	110,0	89,0	1,5	-	-	-	BNSW-10PA	BNSW-10FB	5000
	125,0	101,8	1,5	-	-	-	BNSW-11PA	BNSW-11FB	5000
NPT 3 1/2"	138,0	114,4	2,0	-	-	-	BNSW-12PA	BNSW-12FB	5000
	165,0	141,5	2,0	-	-	-	BNSW-13PA	BNSW-13FB	5000

Gaskets (Washers) for PG Size

For Thread Size PG	Outer Ø D mm	Inner Ø ID mm	Height h mm	CR	NBR	Part Number Silicone	Polyamide	Fibre	Minimum Order Quantity
				black	black	red	white	green	
PG 7	16,8	11,8	1,5	BSSW-01C	BSSW-01N	BSSW-01SR	-	-	20000
	17,0	12,6	1,5	-	-	-	BSSW-1PA	BSSW-1FB	20000
PG 9	21,8	14,5	1,5	BSSW-02C	BSSW-02N	BSSW-02SR	-	-	20000
	20,0	15,3	1,5	-	-	-	BSSW-2PA	BSSW-2FB	20000
PG 11	25,8	17,5	1,5	BSSW-03C	BSSW-03N	BSSW-03SR	-	-	20000
	23,5	18,7	1,5	-	-	-	BSSW-3PA	BSSW-3FB	20000
PG 13,5	27,8	19,8	1,5	BSSW-04C	BSSW-04N	BSSW-04SR	-	-	20000
	27,5	20,5	1,5	-	-	-	BSSW-4PA	BSSW-4FB	20000
PG 16	29,8	21,8	1,5	BSSW-05C	BSSW-05N	BSSW-05SR	-	-	20000
	29,5	22,6	1,5	-	-	-	BSSW-5PA	BSSW-5FB	20000
PG 21	35,8	27,0	1,5	BSSW-06C	BSSW-06N	BSSW-06SR	-	-	20000
	35,5	28,4	1,5	-	-	-	BSSW-6PA	BSSW-6FB	20000
PG 29	46,8	35,5	1,5	BSSW-07C	BSSW-07N	BSSW-07SR	-	-	20000
	46,5	37,1	1,5	-	-	-	BSSW-7PA	BSSW-7FB	20000
PG 36	59,0	45,5	1,5	BSSW-08C	BSSW-08N	BSSW-08SR	-	-	10000
	57,5	47,2	1,5	-	-	-	BSSW-8PA	BSSW-8FB	10000
PG 42	66,8	52,8	1,5	BSSW-09C	BSSW-09N	BSSW-09SR	-	-	5000
	66,5	54,2	1,5	-	-	-	BSSW-9PA	BSSW-9FB	5000
PG 48	71,8	57,8	1,5	BSSW-10C	BSSW-10N	BSSW-10SR	-	-	5000
	72,0	59,5	1,5	-	-	-	BSSW-10PA	BSSW-10FB	5000

Serrated Washers

Serrated washers

- To fix lock nuts when mechanical stress occurs.

Technical Details

Material Brass Nickel plated, Stainless Steel

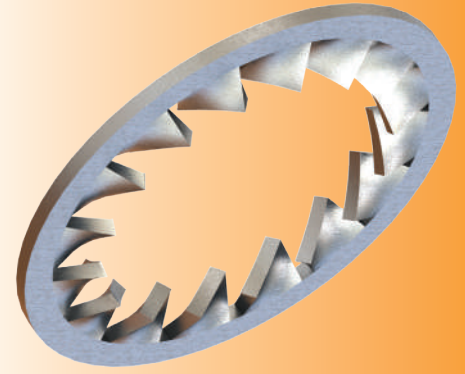
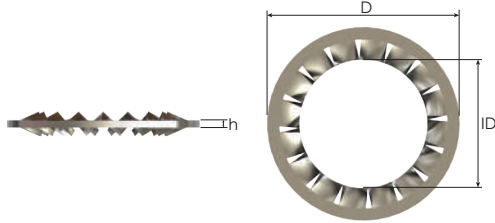

Serrated Washers

For Thread Size		Outer Ø	Inner Ø	Height	Part Number		Minimum Order Quantity
Metric	NPT	D mm	ID mm	h mm	Brass Nickel plated	Stainless Steel	
M16	NPT 3/8"	25,5	17,2	1,5	BMTW-02BN	BMTW-02X	1000
M20	NPT 1/2"	32,5	21,4	1,5	BMTW-03BN	BMTW-03X	1000
M25	NPT 3/4"	40,0	26,7	1,5	BMTW-04BN	BMTW-04X	1000
M32	NPT 1"	43,5	33,5	1,5	BMTW-05BN	BMTW-05X	500
M40	NPT 1 1/4"	64,5	42,2	1,5	BMTW-06BN	BMTW-06X	500
M50	NPT 1 1/2"	80,0	50,7	1,5	BMTW-07BN	BMTW-07X	300
M60	-	97,0	60,3	1,5	BMTW-08SBN	BMTW-08SX	200
M63	NPT 2"	100,0	63,4	1,5	BMTW-08BN	BMTW-08X	200
M70	-	112,0	70,2	1,5	BMTW-09SBN	BMTW-09SX	100
M75	NPT 2 1/2"	112,0	76,4	1,5	BMTW-09BN	BMTW-09X	100
M80	-	121,0	80,2	1,5	BMTW-10SBN	BMTW-10SX	100
M85	-	128,0	85,3	1,5	BMTW-10MBN	BMTW-10MX	100
M90	NPT 3"	135,0	90,5	1,5	BMTW-10BN	BMTW-10X	100
M100	NPT 3 1/2"	145,0	102,1	1,5	BMTW-11BN	BMTW-11X	100
M110	-	151,0	110,3	1,5	BMTW-11MBN	BMTW-11MX	100
M115	NPT 4"	159,0	116,6	1,5	BMTW-11LBN	BMTW-11LX	100
M130	-	181,5	131,5	1,5	BMTW-13BN	BMTW-13X	50
-	NPT 5"	185,0	141,5	1,5	BMTW-14BN	BMTW-14X	50



Technical Details	
Material	Brass, Brass Nickel Plated, Stainless Steel
For more information see our webpage.	

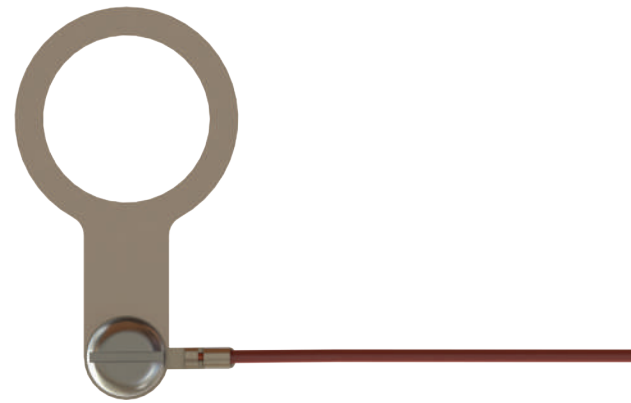
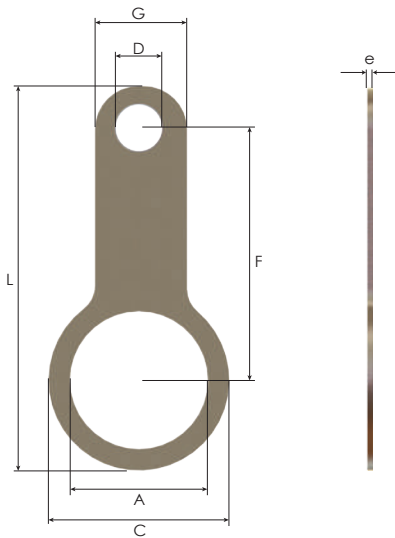

Type METRIC										Type NPT									
For Thread Size	Dimensions							Part Number	Minimum Order Quantity	For Thread Size	Dimensions							Part Number	Minimum Order Quantity
	A Ø mm	e mm	C Ø mm	D Ø mm	L mm	F mm	G mm				A Ø mm	e mm	C Ø mm	D Ø mm	L mm	F mm	G mm		
M12	12,20	1,5	22,0	6,2	46,00	30,0	12,0	BMET02	1000	NPT 1/4"	13,90	1,5	22,0	6,2	47,0	30,0	12,0	BNET02	1000
M16	16,20	1,5	25,0	6,2	48,75	30,0	12,5	BMET01	1000	NPT 3/8"	17,35	1,5	25,0	6,2	48,75	30,0	12,5	BNET01	1000
M20	20,20	1,5	28,6	6,2	53,55	33,0	12,5	BMET1	1000	NPT 1/2"	21,70	1,5	28,6	6,2	53,55	33,0	12,5	BNET1	1000
M25	25,20	1,5	34,0	6,2	59,50	36,0	13,0	BMET2	1000	NPT 3/4"	26,90	1,5	34,0	6,2	59,50	36,0	13,0	BNET2	1000
M32	32,20	1,5	42,0	12,2	73,00	41,0	22,0	BMET3	1000	NPT 1"	33,60	1,5	42,0	12,2	73,00	41,0	22,0	BNET3	700
M40	40,20	1,5	54,0	14,2	86,50	46,5	26,0	BMET4	700	NPT 1 1/4"	42,35	1,5	54,0	14,2	86,50	46,5	26,0	BNET4	500
M50	50,20	1,5	67,0	14,2	111,50	63,5	29,0	BMET5	500	NPT 1 1/2"	48,50	1,5	67,0	14,2	111,50	63,5	29,0	BNET5	350
M60	60,20	1,5	74,0	14,2	121,50	70,0	29,0	BMET60	400	NPT 2"	60,50	1,5	77,0	14,2	125,50	72,5	29,0	BNET6	30
M63	63,20	1,5	77,0	14,2	125,50	72,5	29,0	BMET6	400	NPT 2 1/2"	73,50	1,5	89,0	14,2	137,00	77,0	32,0	BNET7	200
M70	70,20	1,5	84,0	14,2	133,00	75,0	32,0	BMET70	300	NPT 3"	89,50	1,5	109,5	14,2	167,00	94,5	35,5	BNET8	100
M75	75,20	1,5	89,0	14,2	137,50	77,0	32,0	BMET7	300	NPT 3 1/2"	102,20	1,5	122,5	14,2	179,00	100,0	35,5	BNET9	50
M80	80,20	1,5	100,0	14,2	158,00	91,5	32,0	BMET80	200	NPT 4"	114,80	1,5	138,0	14,2	214,00	125,0	40,0	BNET10	50
M85	85,20	1,5	105,0	14,2	161,00	92,5	32,0	BMET85	200										
M90	90,20	1,5	109,5	14,2	167,00	94,5	35,5	BMET8	200										
M100	100,20	1,5	128,0	14,2	209,00	125,0	40,0	BMET9	150										
M110	110,20	1,5	138,0	14,2	214,00	125,0	40,0	BMET10	100										
M115	115,20	1,5	143,0	14,2	219,50	128,0	40,0	BMET115	50										
M130	130,20	1,5	158,0	14,2	232,00	133,0	40,0	BMET130	50										

Lock Nuts Flanged, Polyamide

Lock nuts, flanged

- For standard industrial applications.
- Safe fastening of cable glands.
- Flanged design offers safe sealing.

Technical Details

Material	PA 6 GF 30 (Polyamide 6, 30% Glass Fiber Reinforced)	
Flammability	HB according to UL94	
Operating Temperature	Permanent	Intermittent
	-20 °C to +100 °C	-30 °C to +150 °C
Thread Type	<ul style="list-style-type: none"> • Metric EN 60423 • NPT ANSI B1.20.1 • PG DIN 40430 • Gas ISO 228 	

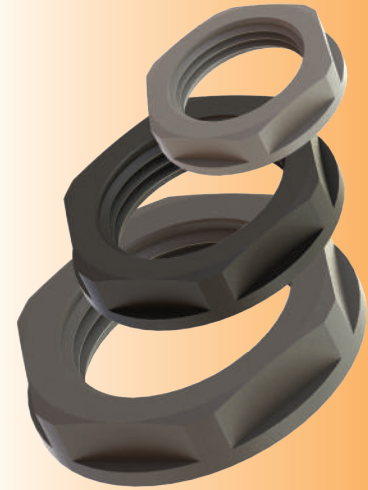
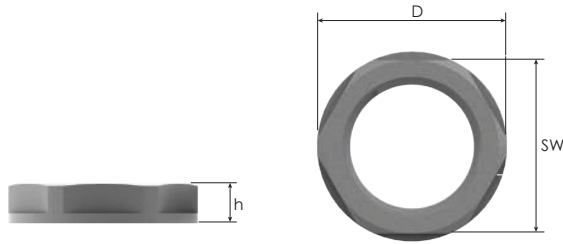

Lock Nuts for METRIC application acc. to EN 60423

Inner Thread Size (Female)	Spanner Width SW mm	Outer Ø D mm	Height h mm	RAL 7035	Part Number		Minimum Order Quantity
				light grey	RAL 7001	RAL 9005	
M12x1,5	18	19,5	5,0	BML-1S	BML-0S	BML-2S	10000
M16x1,5	22	24,2	5,0	BML-11	BML-01	BML-21	10000
M20x1,5	26	28,6	6,0	BML-12	BML-02	BML-22	5000
M25x1,5	32	35,0	6,0	BML-13	BML-03	BML-23	5000
M32x1,5	41	46,1	7,0	BML-14	BML-04	BML-24	2500
M40x1,5	50	55,3	7,0	BML-15	BML-05	BML-25	1500
M50x1,5	60	65,7	8,0	BML-16	BML-06	BML-26	1000
M63x1,5	75	82,5	8,0	BML-17	BML-07	BML-27	1000
M75x2,0	85	94,0	15,0	BML-18	BML-08	BML-28	500

Lock Nuts for NPT application acc. to ANSI B1.20.1

Inner Thread Size (Female)	Spanner Width SW mm	Outer Ø D mm	Height h mm	RAL 7035	Part Number		Minimum Order Quantity
				light grey	RAL 7001	RAL 9005	
for NPT 3/8"	22	25,0	7,0	BPL-11	BPL-01	BPL-21	10000
for NPT 1/2"	27	30,5	7,0	BPL-12	BPL-02	BPL-22	5000
for NPT 3/4"	33	37,5	7,0	BPL-13	BPL-03	BPL-23	3000
for NPT 1"	41	46,2	7,0	BPL-14	BPL-04	BPL-24	2000

Lock Nuts for PG application acc. to DIN 40430

Inner Thread Size (Female)	Spanner Width SW mm	Outer Ø D mm	Height h mm	RAL 7035	Part Number		Minimum Order Quantity
				light grey	RAL 7001	RAL 9005	
PG 7	19	20,9	5,0	BL-11	BL-01	BL-21	10000
PG 9	22	23,9	5,0	BL-12	BL-02	BL-22	10000
PG 11	24	25,9	5,0	BL-13	BL-03	BL-23	10000
PG 13,5	27	28,9	6,0	BL-14	BL-04	BL-24	5000
PG 16	30	32,9	6,0	BL-15	BL-05	BL-25	5000
PG 21	36	38,8	7,0	BL-16	BL-06	BL-26	3000
PG 29	46	49,8	7,0	BL-17	BL-07	BL-27	2000
PG 36	60	65,7	8,0	BL-18	BL-08	BL-28	1500
PG 42	65	72,7	8,0	BL-19	BL-09	BL-29	1000
PG 48	70	77,7	8,0	BL-20	BL-10	BL-30	1000

Lock Nuts for G application acc. to G ISO 228

Inner Thread Size (Female)	Spanner Width SW mm	Outer Ø D mm	Height h mm	RAL 7035	Part Number		Minimum Order Quantity
				light grey	RAL 7001	RAL 9005	
G 3/8"	22	25,0	6,0	BFL-11	BFL-01	BFL-21	10000
G 1/2"	27	30,5	6,0	BFL-12	BFL-02	BFL-22	5000
G 3/4"	33	37,5	6,4	BFL-13	BFL-03	BFL-23	3000
G 1"	42	47,5	6,5	BFL-14	BFL-04	BFL-24	2000

Lock Nuts Without Flange, Polyamide



Technical Details

Material PA 6 GF 30 (Polyamide 6, 30% Glass Fiber Reinforced)

For more information see our webpage.

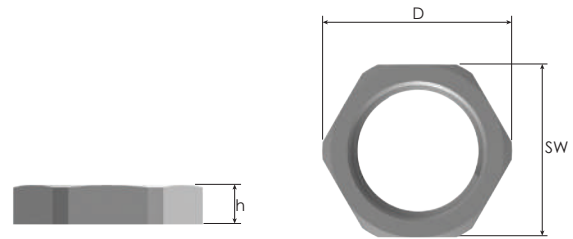

Thread Type **METRIC** acc. to EN 60423

Inner Thread Size (Female)	Spanner Width SW mm	Outer Ø D mm	Height h mm	Part Number			Minimum Order Quantity
				RAL 7035 light grey	RAL 7001 grey	RAL 9005 black	
M6x0,75	10	11,0	5,0	BLMN-1S6	BLMN-0S6	BLMN-2S6	100
M8x1,0	12	13,0	5,0	BLMN-1S8	BLMN-0S8	BLMN-2S8	100
M12x1,5	18	19,5	5,0	BLMN-1S	BLMN-0S	BLMN-2S	100
M16x1,5	22	24,2	5,0	BLMN-11	BLMN-01	BLMN-21	50
M20x1,5	26	28,6	6,0	BLMN-12	BLMN-02	BLMN-22	50
M25x1,5	32	35,0	6,0	BLMN-13	BLMN-03	BLMN-23	50
M32x1,5	41	46,1	7,0	BLMN-14	BLMN-04	BLMN-24	25
M40x1,5	50	55,3	7,0	BLMN-15	BLMN-05	BLMN-25	10
M50x1,5	60	66,1	8,0	BLMN-16	BLMN-06	BLMN-26	10
M63x1,5	75	82,5	8,0	BLMN-17	BLMN-07	BLMN-27	10

Thread Type **PG** acc. to DIN 40430

Inner Thread Size (Female)	Spanner Width SW mm	Outer Ø D mm	Height h mm	Part Number			Minimum Order Quantity
				RAL 7035 light grey	RAL 7001 grey	RAL 9005 black	
PG 7	19	20,9	5,0	BLN-11	BLN-01	BLN-21	100
PG 9	22	23,9	5,0	BLN-12	BLN-02	BLN-22	100
PG 11	24	25,9	5,0	BLN-13	BLN-03	BLN-23	50
PG 13,5	27	28,9	6,0	BLN-14	BLN-04	BLN-24	50
PG 16	30	32,9	6,0	BLN-15	BLN-05	BLN-25	50
PG 21	36	38,8	7,0	BLN-16	BLN-06	BLN-26	25
PG 29	46	49,8	7,0	BLN-17	BLN-07	BLN-27	25
PG 36	60	65,7	8,0	BLN-18	BLN-08	BLN-28	25
PG 42	65	72,7	8,0	BLN-19	BLN-09	BLN-29	10
PG 48	70	77,7	8,0	BLN-20	BLN-10	BLN-30	10

Lock Nuts, Metal

Lock Nuts, Metal

- For standard industrial applications in harsh environments.
- Safe fastening of cable glands.

Technical Details

Material	Brass Nickel plated, Stainless Steel
Thread Type	<ul style="list-style-type: none"> • Metric EN 60423 • NPSL ANSI B1.20.1 • PG DIN 40430 • G (PF) DIN ISO 228

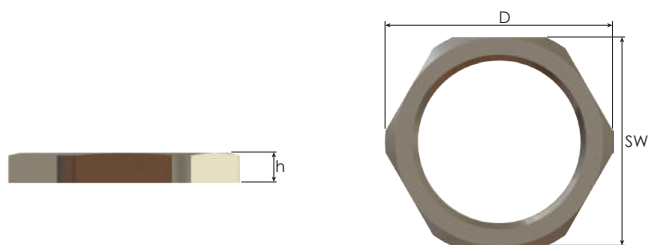

Thread Type METRIC acc. to EN 60423

Inner Thread Size (Female)	Spanner Width	Brass Nickel Plated			Part Number	Spanner Width	Stainless Steel			Minimum Order Quantity
		Outer Ø	Height				Outer Ø	Height		
	SW mm	D mm	h mm			D mm	h mm			
M12x1,5	15	16,6	2,8	BMBL-01	15	16,6	2,8	BMBLS-01	8000	
M16x1,5	19	21,0	3,0	BMBL-02	19	21,0	3,0	BMBLS-02	5000	
M20x1,5	24	26,5	3,5	BMBL-03	24	26,5	3,5	BMBLS-03	2500	
M25x1,5	30	33,0	4,0	BMBL-04	30	33,0	4,0	BMBLS-04	1500	
M32x1,5	36	39,5	5,0	BMBL-05	36	39,5	5,0	BMBLS-05	1200	
M40x1,5	46	51,0	5,0	BMBL-06	46	51,0	5,0	BMBLS-06	700	
M50x1,5	60	66,0	5,0	BMBL-07	60	66,0	5,0	BMBLS-07	350	
M63x1,5	70	77,0	6,0	BMBL-08	70	77,0	6,0	BMBLS-08	300	
M70x1,5	75	83,0	7,0	BMBL-09S	75	83,0	7,0	BMBLS-09S	250	
M72x2,0	77	86,0	7,0	BMBL-09	77	86,0	7,0	BMBLS-09	250	
M75x1,5	80	89,0	7,0	BMBL-10S	80	89,0	7,0	BMBLS-10S	200	
M75x2,0	80	89,6	7,0	BMBL-10	80	89,6	7,0	BMBLS-10	200	
M80x2,0	90	100,0	8,0	BMBL-11	90	100,0	8,0	BMBLS-11	100	
M85x1,5	95	106,2	8,0	BMBL-12S	95	106,2	8,0	BMBLS-12S	100	
M85x2,0	95	106,2	8,0	BMBL-12	95	106,2	8,0	BMBLS-12	100	
M90x1,5	100	112,0	8,0	BMBL-13S	100	112,0	8,0	BMBLS-13S	100	
M90x2,0	100	112,0	8,0	BMBL-13	100	112,0	8,0	BMBLS-13	100	
M100x1,5	120	128,0	10,0	BMBL-14	120	128,0	10,0	BMBLS-14	50	
M110x1,5	130	145,0	10,0	BMBL-15	130	145,0	10,0	BMBLS-15	50	
M115x2,0	135	151,0	10,0	BMBL-16	135	151,0	10,0	BMBLS-16	50	
M130x2,0	150	167,0	12,0	BMBL-18	150	167,0	12,0	BMBLS-18	50	

Thread Type NPSL acc. to ANSI B1.20.1

Inner Thread Size (Female)	Spanner Width	Brass Nickel Plated			Part Number	Spanner Width	Stainless Steel			Minimum Order Quantity
		Outer Ø	Height				Outer Ø	Height		
	SW mm	D mm	h mm			D mm	h mm			
NPSL 1/4"	17,0	18,8	5,0	BNLN-01S	17,0	18,8	5,0	BNLNS-01S	3000	
NPSL 3/8"	24,0	26,5	5,0	BNLN-01	24,0	26,5	5,0	BNLNS-01	3000	
NPSL 1/2"	24,0	26,5	5,0	BNLN-02	24,0	26,5	5,0	BNLNS-02	2500	
NPSL 3/4"	34,0	37,5	6,0	BNLN-03	35,0	39,0	6,0	BNLNS-03	1200	
NPSL 1"	42,0	46,4	6,0	BNLN-04	46,0	51,0	6,0	BNLNS-04	1200	
NPSL 1 1/4"	52,0	57,4	7,0	BNLN-05	55,0	61,0	7,0	BNLNS-05	350	
NPSL 1 1/2"	60,0	65,1	7,0	BNLN-06	60,0	65,1	7,0	BNLNS-06	300	
NPSL 2"	74,0	81,8	8,0	BNLN-07	74,0	81,8	8,0	BNLNS-07	250	
NPSL 2 1/2"	80,0	89,0	10,0	BNLN-08	80,0	89,0	10,0	BNLNS-08	100	
NPSL 3"	95,0	105,0	10,0	BNLN-09	95,0	105,0	10,0	BNLNS-09	50	
NPSL 3 1/2"	115,0	128,5	10,0	BNLN-10	115,0	128,5	10,0	BNLNS-10	50	
NPSL 4"	130,0	145,0	10,0	BNLN-11	130,0	145,0	10,0	BNLNS-11	50	
NPSL 5"	160,0	178,5	12,0	BNLN-12	160,0	178,5	12,0	BNLNS-12	50	

Lock Nuts, Metal

Lock Nuts, Metal

- For standard industrial applications in harsh environments.
- Safe fastening of cable glands.

Technical Details

Material	Brass Nickel plated, Stainless Steel
Thread Type	<ul style="list-style-type: none"> • Metric EN 60423 • NPSL ANSI B1.20.1 • PG DIN 40430 • G (PF) DIN ISO 228

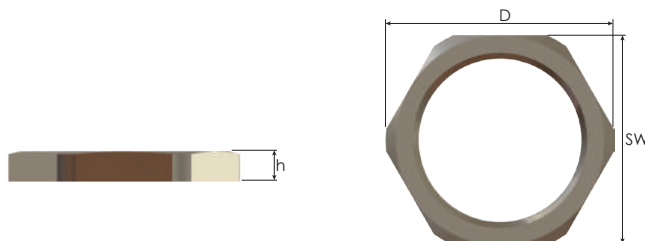

Thread Type PG acc. to DIN 40430

Inner Thread Size (Female)	Spanner Width	Brass Nickel Plated			Part Number	Stainless Steel			Minimum Order Quantity
		Outer Ø	Height			Outer Ø	Height		
	SW mm	D mm	h mm		SW mm	D mm	h mm		
PG 7	15	16,6	2,8	BSL-01	17	18,6	2,8	BSLS-01	8000
PG 9	18	20,0	2,8	BSL-02	19	21,0	2,8	BSLS-02	5000
PG 11	21	23,5	3,0	BSL-03	22	24,5	3,0	BSLS-03	5000
PG 13,5	23	25,5	3,0	BSL-04	24	26,5	3,0	BSLS-04	4000
PG 16	26	29,0	3,0	BSL-05	27	30,0	3,0	BSLS-05	3500
PG 21	32	35,5	3,5	BSL-06	32	35,5	3,5	BSLS-06	2000
PG 29	41	45,0	4,0	BSL-07	41	45,0	4,0	BSLS-07	1300
PG 36	51	56,0	5,0	BSL-08	60	66,0	5,0	BSLS-08	800
PG 42	60	66,0	5,0	BSL-09	60	66,0	5,0	BSLS-09	400
PG 48	64	70,5	5,5	BSL-10	65	71,5	5,5	BSLS-10	350

Thread Type G acc. to DIN ISO 228

Inner Thread Size (Female)	Spanner Width	Brass Nickel Plated			Part Number	Stainless Steel			Minimum Order Quantity
		Outer Ø	Height			Outer Ø	Height		
	SW mm	D mm	h mm		SW mm	D mm	h mm		
G 3/8"	22	24,5	5,0	BPFL-01	22	24,5	5,0	BPFLS-01	4000
G 1/2"	27	30,0	5,0	BPFL-02	27	30,0	5,0	BPFLS-02	2500
G 3/4"	33	36,5	5,0	BPFL-03	36	39,5	5,0	BPFLS-03	1200
G 1"	43	46,5	5,0	BPFL-04	46	51,0	5,0	BPFLS-04	1200
G 1 1/4"	48	53,0	5,0	BPFL-05	50	55,5	5,0	BPFLS-05	350
G 1 1/2"	55	61,0	5,0	BPFL-06	55	61,0	5,0	BPFLS-06	300
G 2"	64	70,5	5,5	BPFL-07	65	71,5	5,5	BPFLS-07	300
G 4"	130	145,0	8,0	BPFL-11	130	145,0	8,0	BPFLS-11	200

Lock Nuts EMC, Metal

Lock Nuts, EMC, Metal

- For EMC applications of high quality metal machines and housings.
- For high quality applications in corrosive environments.
- Safe fastening of EMC cable glands.

Technical Details

Material	Brass Nickel plated, Stainless Steel
Thread Type	<ul style="list-style-type: none"> • Metric EN 60423 • PG DIN 40430

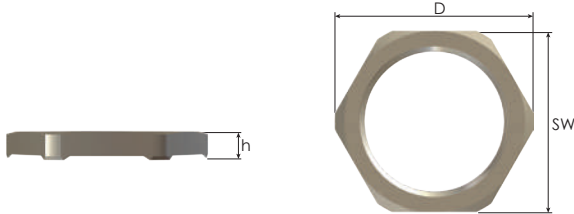

Thread Type **METRIC** acc. to EN 60423

Inner Thread Size (Female)	Brass Nickel Plated				Stainless Steel				Minimum Order Quantity
	SW mm	Outer Ø D mm	Height h mm	Part Number	SW mm	Outer Ø D mm	Height h mm	Part Number	
M12x1,5	15	16,5	3,3	BMEL-01	15	16,5	3,3	BMELS-01	8000
M16x1,5	19	21,0	3,5	BMEL-02	19	21,0	3,5	BMELS-02	5000
M20x1,5	24	26,5	3,7	BMEL-03	24	26,5	3,7	BMELS-03	2500
M25x1,5	30	33,0	3,7	BMEL-04	30	33,0	3,7	BMELS-04	1500
M32x1,5	36	39,5	4,0	BMEL-05	36	39,5	4,0	BMELS-05	1200
M40x1,5	46	51,0	4,6	BMEL-06	46	51,0	4,6	BMELS-06	700
M50x1,5	60	66,0	5,6	BMEL-07	60	66,0	5,6	BMELS-07	350
M63x1,5	70	77,0	6,7	BMEL-08	70	77,0	6,7	BMELS-08	300

Thread Type **PG** acc. to DIN 40430

Inner Thread Size (Female)	Brass Nickel Plated				Stainless Steel				Minimum Order Quantity
	SW mm	Outer Ø D mm	Height h mm	Part Number	SW mm	Outer Ø D mm	Height h mm	Part Number	
PG 7	15	16,5	3,3	BSEL-01	15	16,5	3,3	BSELS-01	8000
PG 9	18	20,0	3,3	BSEL-02	18	20,0	3,3	BSELS-02	5000
PG 11	21	23,5	3,5	BSEL-03	21	23,5	3,5	BSELS-03	5000
PG 13,5	23	25,5	3,5	BSEL-04	23	25,5	3,5	BSELS-04	4000
PG 16	26	29,0	3,5	BSEL-05	26	29,0	3,5	BSELS-05	3500
PG 21	32	35,5	4,0	BSEL-06	32	35,5	4,0	BSELS-06	2000
PG 29	41	45,0	4,6	BSEL-07	41	45,0	4,6	BSELS-07	1300
PG 36	51	56,0	5,6	BSEL-08	51	56,0	5,6	BSELS-08	800
PG 42	60	66,0	5,6	BSEL-09	60	66,0	5,6	BSELS-09	400
PG 48	64	70,5	6,1	BSEL-10	64	70,5	6,1	BSELS-10	350

Thread Type **NPSL** acc. to DIN 40430

Inner Thread Size (Female)	Brass Nickel Plated				Stainless Steel				Minimum Order Quantity
	SW mm	Outer Ø D mm	Height h mm	Part Number	SW mm	Outer Ø D mm	Height h mm	Part Number	
NPSL 1/4"	17	18,8	5,5	BNEL-01S	17	18,8	5,5	BNELS-01S	3000
NPSL 3/8"	22	24,0	5,7	BNEL-01	22	24,0	5,7	BNELS-01	3000
NPSL 1/2"	24	26,5	6,7	BNEL-02	24	26,5	6,7	BNELS-02	2500
NPSL 3/4"	30	33,0	6,5	BNEL-03	30	33,0	6,5	BNELS-03	1200
NPSL 1"	40	44,5	7,6	BNEL-04	40	44,5	7,6	BNELS-04	1200
NPSL 1 1/4"	50	55,5	7,6	BNEL-05	50	55,5	7,6	BNELS-05	350
NPSL 1 1/2"	58	64,0	8,7	BNEL-06	58	64,0	8,7	BNELS-06	300
NPSL 2"	70	78,0	10,8	BNEL-07	70	78,0	10,8	BNELS-07	250
NPSL 2 1/2"	80	89,0	10,8	BNEL-08	80	89,0	10,8	BNELS-08	100
NPSL 3"	95	105,0	10,8	BNEL-09	95	105,0	10,8	BNELS-09	50
NPSL 3 1/2"	115	128,0	10,8	BNEL-10	115	128,0	10,8	BNELS-10	50
NPSL 4"	130	145,0	10,8	BNEL-11	130	145,0	10,8	BNELS-11	50
NPSL 5"	160	176,0	13,0	BNEL-12	160	176,0	13,0	BNELS-12	50

Shrouds



Technical Details			
Orion Type		E-Octans and E-Vela Type	
Material	Type 1	Type 2	Type 2
	CR (Chloroprene), EPDM	PVC	PVC

For more information see our webpage.

Type 1

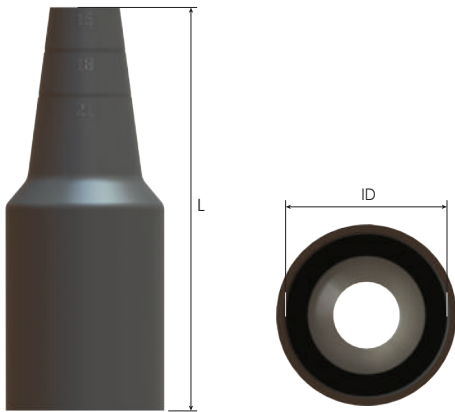

Type 2

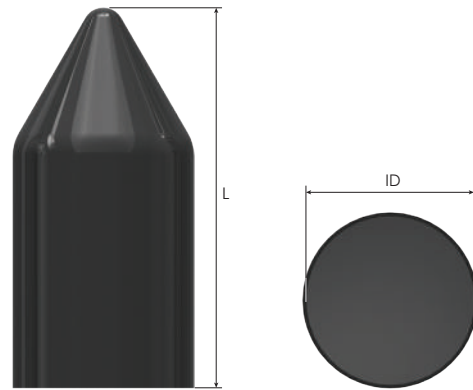

Type 1

ORION Type Shrouds (CR or EPDM)				
For Gland Code	Inner Ø Total Length		Part Number	
	ID mm	L mm	CR	EPDM
KBA01, KBA1, KBA2S	31,7	92,5	BMCR1KBA	BMEP1KBA
KBA2	37,2	102,1	BMCR2KBA	BMEP2KBA

Type 2

ORION Type Shrouds (PVC)				E-OCTANS And E-VELA Type Shrouds (PVC)			
For Gland Code	Inner Ø ID mm	Total Length L mm	Part Number	For Gland Code	Inner Ø ID mm	Total Length L mm	Part Number
							For E-Octans and E-Vela
KBA0S, KBA01S, KBA1S	29,1	67,0	BMSH1SKBA	EBU0, EBU01S, EBS01S	22,0	52,7	BMSH01EBU
KBA01, KBA1, KBA2XS, KBA2S	31,7	68,0	BMSH1KBA	EBU0S, EBU01, EBU1, EBU1S, EBS01, EBS1	24,5	56,1	BMSH1EBU
KBA1L	35,2	76,6	BMSH1LKBA	EBU12, EBU2, EBU2S, EBS2	31,0	67,5	BMSH2EBU
KBA2, KBA3XS	37,2	78,6	BMSH2KBA	EBU23, EBU3, EBU3S, EBS3	39,0	72,6	BMSH3EBU
KBA2L, KBA3S	44,2	81,6	BMSH2LKBA	EBU34, EBU4, EBU4S, EBS4	49,5	91,7	BMSH4EBU
KBA4X	49,0	90,8	BMSH4XSKBA	EBU45	56,1	88,0	BMSH45EBU
KBA3, KBA4S, KBA5XS	57,2	112,0	BMSH3KBA	EBU5, EBU5S, EBS5	61,0	88,0	BMSH5BU
KBA4, KBA5XM	66,2	117,1	BMSH4KBA	EBU56	70,1	93,9	BMSH56EBU
KBA5S, KBA6XS	82,2	132,6	BMSH5SKBA	EBU6, EBU6S, EBS6	74,9	95,5	BMSH6EBU
KBA5, KBA6XM	83,2	132,6	BMSH5KBA	EBU67, EBU7, EBU7S, EBS7	89,0	108,6	BMSH7EBU
KBA6S, KBA7XSN	89,7	148,0	BMSH6SKBA	EBU78, EBU8, EBU8S, EBS8	105,0	126,5	BMSH8EBU
KBA6, KBA7XSM, KBA7S	94,2	143,8	BMSH6KBA	EBU810, EBU10, EBU10SM, EBU108N, EBS10M	117,0	163,5	BMSH10EBU
KBA8XSN	103,0	171,1	BMSH8XSNKBA	EBU11, EBS10N, EBS11	128,0	175,5	BMSH11EBU
KBA6L, KBA7, KBA8XSM, KBA8S	110,6	182,7	BMSH7KBA	EBU115, EBU115XSM, EBU115SM	144,0	194,5	BMSH115EBU
KBA9SN	120,0	184,0	BMSH9SNKBA	EBU13, EBU130N	154,0	209,2	BMSH13EBU
KBA10SM	126,0	184,5	BMSH10SMKBA				
KBA8, KBA9N, KBA10M	127,2	222,1	BMSH10MKBA				

CABLE GLAND for Industrial Application



Glands

Thread Diameters and Hole Sizes	294
Strain Relief acc. to EN and acc. to UL	295
IP Rating	296
Type 4x Rating	297
Plastic Cable Gland and Plug Assembling	298 - 299
Metal Cable Gland and Plug Assembling	300 - 301
Product Number INDEX	302 - 303

ACCESSORIES for Industrial Application



Thread Diameters and Hole Sizes

Clearence Hole Diameter

• for non-threaded holes with use of lock nuts

• We recommend the data below. For other dimensions, please consult your point of contact.

Thread Standard Metric acc. to EN 60423				
Size	Outer Diameter max.		Clearence Hole Diameter max.	
	mm	inch	mm	inch
M4	4	0,16	4,1	0,16
M6	6	0,24	6,1	0,24
M8	8	0,31	8,1	0,32
M12	12	0,47	12,2	0,48
M16	16	0,63	16,2	0,64
M20	20	0,79	20,2	0,80
M25	25	0,98	25,2	0,99
M32	32	1,26	32,2	1,27
M40	40	0,39	40,2	1,66
M50	50	1,97	50,3	1,98
M63	63	2,48	63,3	2,49
M72	72	2,83	72,3	2,85
M75	75	2,95	75,3	2,96
M80	80	3,15	80,3	3,16
M85	85	3,35	85,3	3,36
M90	90	3,54	90,3	3,56
M100	100	3,94	100,3	3,95
M110	110	4,33	110,3	4,34
M115	115	4,53	115,3	4,54
M130	130	5,12	130,3	5,13

Thread Standard NPT acc. to ANSI B1.20.1				
Size	Outer Diameter max.		Clearence Hole Diameter max.	
	mm	inch	mm	inch
NPT 1/4"	13,72	0,54	14,0	0,55
NPT 3/8"	17,15	0,68	17,5	0,69
NPT 1/2"	21,34	0,84	21,5	0,85
NPT 3/4"	26,67	1,05	27,0	1,06
NPT 1"	33,40	1,31	34,0	1,34
NPT 1 1/4"	42,16	1,66	42,5	1,67
NPT 1 1/2"	48,26	1,90	48,5	1,91
NPT 2"	60,33	2,38	60,5	2,38
NPT 2 1/2"	73,03	2,88	73,5	2,89
NPT 3"	88,90	3,50	89,5	3,52
NPT 3 1/2"	101,60	4,00	102,0	4,02
NPT 4"	114,30	4,50	115,0	4,53
NPT 5"	141,30	5,56	142,0	5,59

Thread Standard PG acc. to DIN 40430				
Size	Outer Diameter max.		Clearence Hole Diameter max.	
	mm	inch	mm	Inch
PG 7	12,5	0,49	12,7	0,50
PG 9	15,2	0,60	15,4	0,61
PG 11	18,6	0,73	18,8	0,74
PG 13,5	20,4	0,80	20,7	0,81
PG 16	22,5	0,89	22,7	0,89
PG 21	28,3	1,11	28,5	1,12
PG 29	37,0	1,46	37,2	1,46
PG 36	47,0	1,85	47,3	1,86
PG 42	54,0	2,13	54,3	2,14
PG 48	59,3	2,33	59,6	2,35

Thread Standard G acc. to DIN ISO 228				
Size	Outer Diameter max.		Clearence Hole Diameter max.	
	mm	inch	mm	inch
G 1/4"	13,16	0,52	13,4	0,53
G 3/8"	16,66	0,66	17,0	0,67
G 1/2"	20,96	0,83	21,2	0,83
G 3/4"	26,44	1,04	26,7	1,05
G 1"	33,25	1,31	33,5	1,32
G 1 1/4"	41,91	1,65	42,2	1,66
G 1 1/2"	47,80	1,88	48,0	1,89
G 2"	59,61	2,35	60,0	2,36
G 2 1/2"	75,18	2,96	75,5	2,97
G 3"	87,88	3,46	88,4	3,48
G 3 1/2"	100,33	3,95	101,0	3,98
G 4"	113,03	4,45	113,5	4,47
G 5"	138,43	5,45	139,0	5,47

Strain Relief

Laboratory tests and approvals acc. to **EN 62444**:2013

- non-armoured cables are tested according to Type A and B;
- armoured cables are tested according to Type C (equals Type B).

cable diameter	Pull forces for non-armoured cables Type A	Pull forces for non-armoured cables Type B and armoured cables Type C
up to 4 mm	5 N (cable retention)	5 N (cable retention)
> 4 - 8 mm	30 N	75 N
> 8 - 11 mm	42 N	120 N
> 11 - 16 mm	55 N	130 N
> 16 - 23 mm	70 N	140 N
> 23 - 31 mm	80 N	250 N
> 31 - 43 mm	90 N	350 N
> 43 - 55 mm	100 N	400 N
> 55 mm	115 N	450 N

Laboratory tests and approvals acc. to **UL 514B**

cable gland thread size	Pull forces for non-armoured cables (flexible cord)	Pull forces for armoured cables
16 mm 1/2"	159 N	333 N
21 mm 3/4"		444 N
27 mm 1"		556 N
35 - 103 mm 1 1/4" - 4"		667 N

Pull force for non-armoured cables

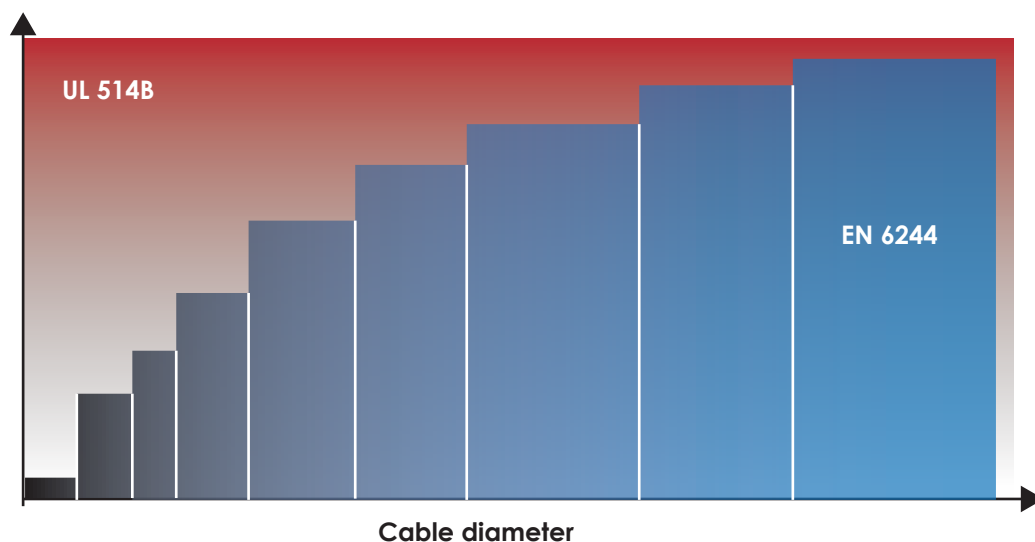

IP Rating

IP means Ingress Protection.

Laboratory tests and approvals acc. to IEC 60529:1989 + A1:1999 + A2:2013, IEC 60529 Edition 2.2 Corrigendum 2:2015.

First digit of IP-code

Protected against foreign objects (incl. dust)	
0	not protected
1	with diameter ≥ 50 mm
2	with diameter $\geq 12,5$ mm
3	with diameter $\geq 2,5$ mm
4	with diameter $\geq 1,0$ mm
5	dust-protected
6	dust-tight

Second digit of IP-code

Protected against water	
0	not protected
1	vertical water drips
2	water drips, 15° inclination
3	water spray
4	splash water
5	high-velocity water
6	strong high-velocity water

Additional protection conditions	
7	temporary immersion (up to 1 m)
8	continuous submersion
9	high-pressure / steam-jet cleaning

Laboratory tests and approvals acc. to UL 50 E; NEMA Standards Publication 250-2003

Type 4X

Either indoor or outdoor use to provide a degree of protection against:

- Incidental contact with the enclosed equipment;
- Falling dirt;
- Falling liquids and light splashing;
- Dust, lint, fibers, and flyings;
- Rain, snow, and sleet;
- Windblown dust;
- Hose-directed water, and splashing water;
- Corrosive agents;
- Undamaged by the formation of ice on the enclosure.

NEMA Type 4X is similar to IP 66.

Cable Gland Assembling Instruction

Assembling with lock nut on **non threaded** enclosure

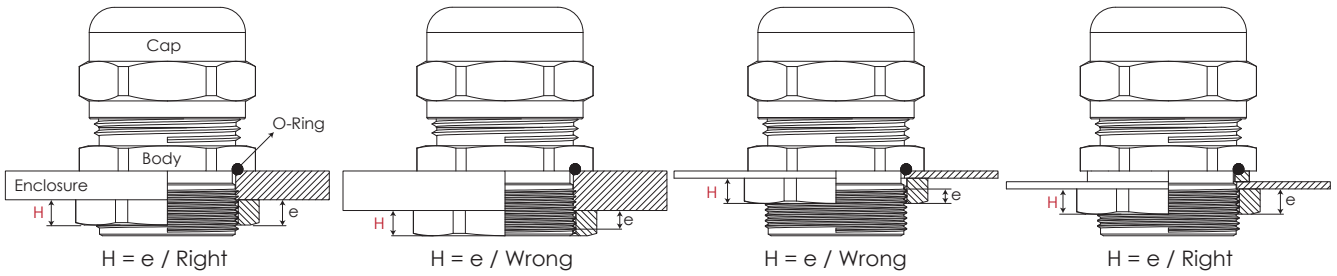

Relevant Lock Nut Thickness

Size	H (±0,5 mm)
M12 Pg 7 to Pg 9	2,8
M16 Pg 11 to Pg 16	3,0
M20 Pg 21	3,5
M25 Pg 29	4,0
M40 to M50 Pg 36 to Pg 42	5,0
- Pg 48	5,5
M63 -	6,0



Assembling with lock nut on **threaded** enclosure

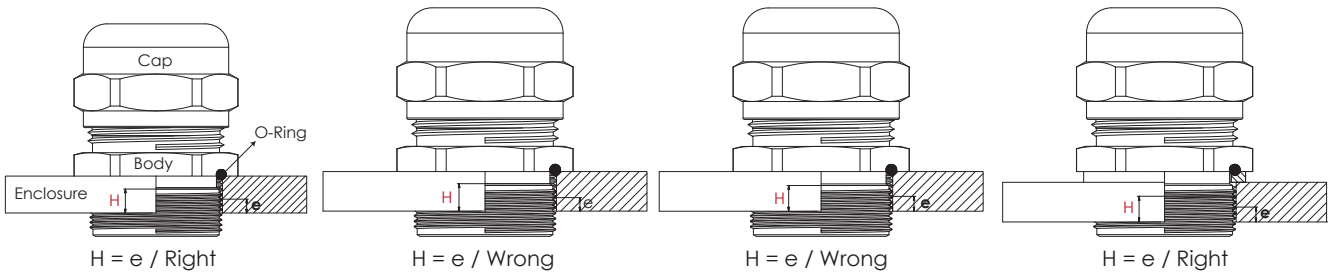

Complementary Instruction

- The engaged thread length "e" must be equal or longer than relevant lock nut thickness "H"
- The thread dimensions and tolerances on threaded enclosures must be convenient with the relevant thread standard.
- Firstly, the gland body must be mounted to the enclosure.
- The body or the lock nut must be tightened according to torque indicated on the instruction chart.
- As much as possible double wrench have to be used for non threaded enclosures.
- For cable assembling the cap must be tightened according to torque indicated on the instruction chart.
- During the cable assembling or disassembling gland body must be keep fixed. Double wrench have to be used for this purpose.

Npt threads application

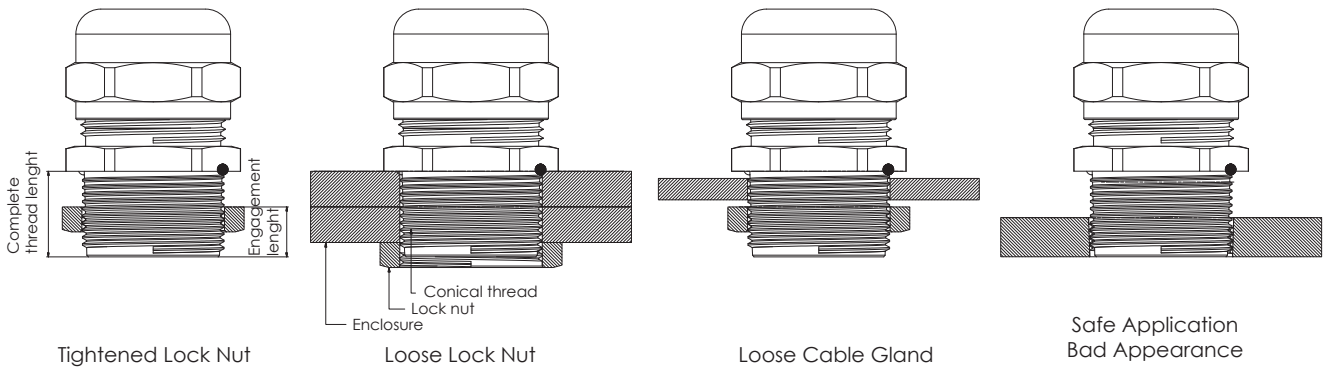

Thread standard	ANSI B1.20.1
Thread name	National Pipe Threads
Thread definition	NPT is an US Standard for "Tapered Threads" used in threaded pipes and fittings. The thread can provide an effective seal for liquids, gases, hydraulic, fluids and steam. They are used generally for steel, brass, cast-iron, PTFE, PVC, PA materials.
Other Appellations	MPT : Male Pipe Threads FPT : Female Pipe Threads
Applications	The NPT threads are always used for male and female pipe / fitting joints. Regarding the conicity of the thread they are not suitable for lock-nut applications.
"Cable Glands" and "Electrical Fitting" applications	The NPT threaded cable glands or male threaded electrical fittings as reducers, blind stops etc must used a NPT female threaded enclosures or cabinets. The usage of lock nuts for NPT threads is not a recommended application. According the relevant standard, the male and female threads have a defined engagement length. When we use a lock nut (even if is NPT threaded), we know that this one will be blocked, after the defined length portion of the male thread. In result we can not be sure that this blocking distance will be suitable for the wall thickness of the enclosure or cabinet. If we are using an equivalent parallel thread lock nut the result will be worst because the male and female thread, will not be in complete contact.

Plug Assembling Instruction

Assembling with lock nut on **non threaded** enclosure

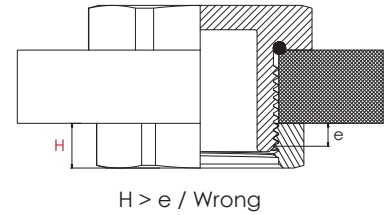
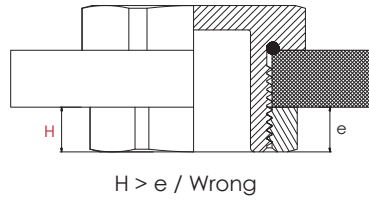
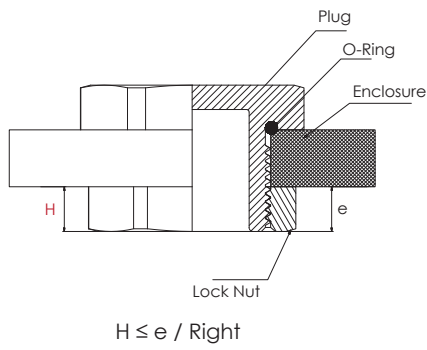

Relevant Lock Nut Thickness

Size	H ($\pm 0,5$ mm)
M12 Pg 7 to Pg 9	2,8
M16 Pg 11 to Pg 16	3,0
M20 Pg 21	3,5
M25 Pg 29	4,0
M40 to M50 Pg 36 to Pg 42	5,0
- Pg 48	5,5
M63 -	6,0



Assembling with lock nut on **threaded** enclosure

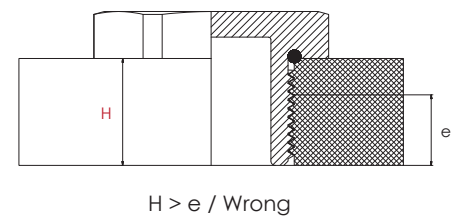
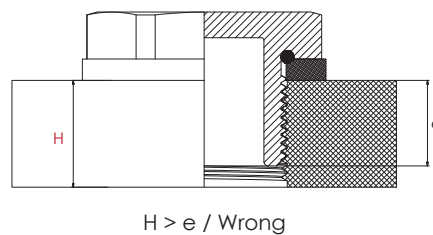
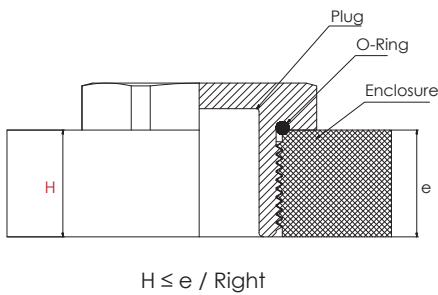

Complementary Instructions:

- The engaged thread length "e" must be equal or longer than relevant lock nut thickness "H"
- The thread dimensions and tolerances on threaded enclosures must be convenient with the relevant thread standard.
- Firstly, the blind stop must be mounted to the enclosure.
- The blind stop or the lock nut must be tightened according to torque indicated on the instruction chart.
- As much as possible double tool have to be used for non threaded enclosures.(Screw driver+wrench)

Cable Gland Assembling Instruction

Assembling with lock nut on **non threaded** enclosure

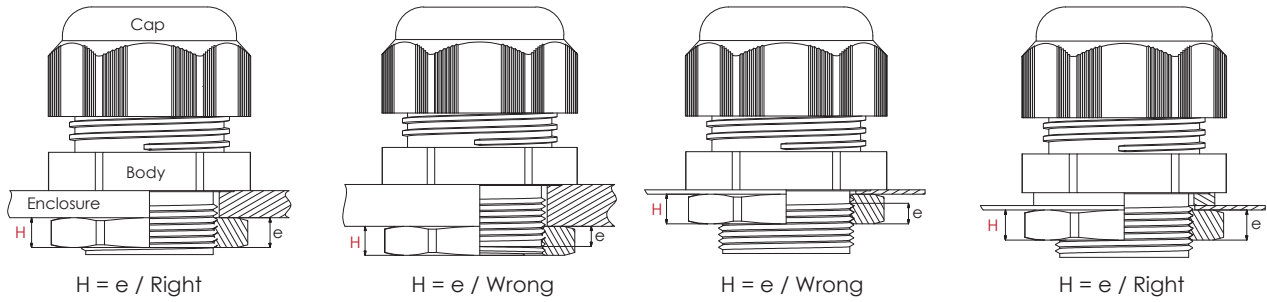

Relevant Lock Nut Thickness

Size	H ($\pm 0,5$ mm)
M12 to M16 Pg 7 to Pg 11	5,0
M20 to M25 Pg 13,5 to Pg 16	6,0
M32 to M40 Pg 21 to Pg 29	7,0
M50 to M63 Pg 36 to Pg 42	8,0



Assembling with lock nut on **threaded** enclosure

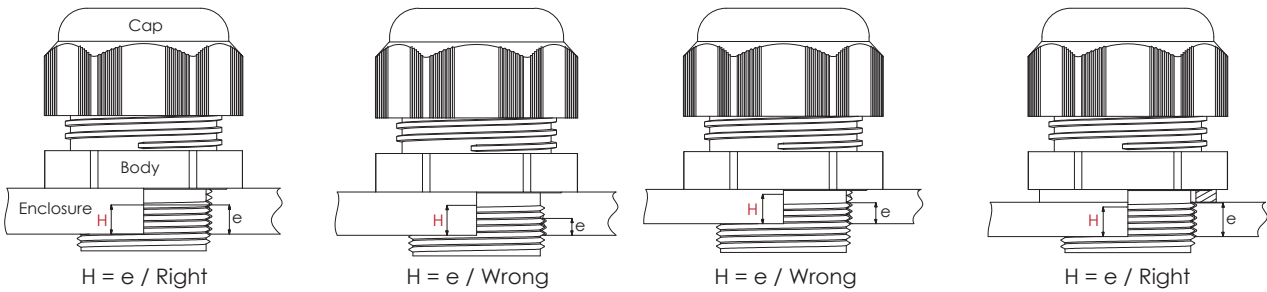

Complementary Instruction

- The engaged thread length "e" must be equal or longer than relevant lock nut thickness "H"
- The thread dimensions and tolerances on threaded enclosures must be convenient with the relevant thread standard.
- Firstly, the gland body must be mounted to the enclosure.
- The body or the lock nut must be tightened according to torque indicated on the instruction chart.
- As much as possible double wrench have to be used for non threaded enclosures.
- For cable assembling the cap must be tightened according to torque indicated on the instruction chart.
- During the cable assembling or disassembling gland body must be keep fixed. Double wrench have to be used for this purpose.

Npt threads application

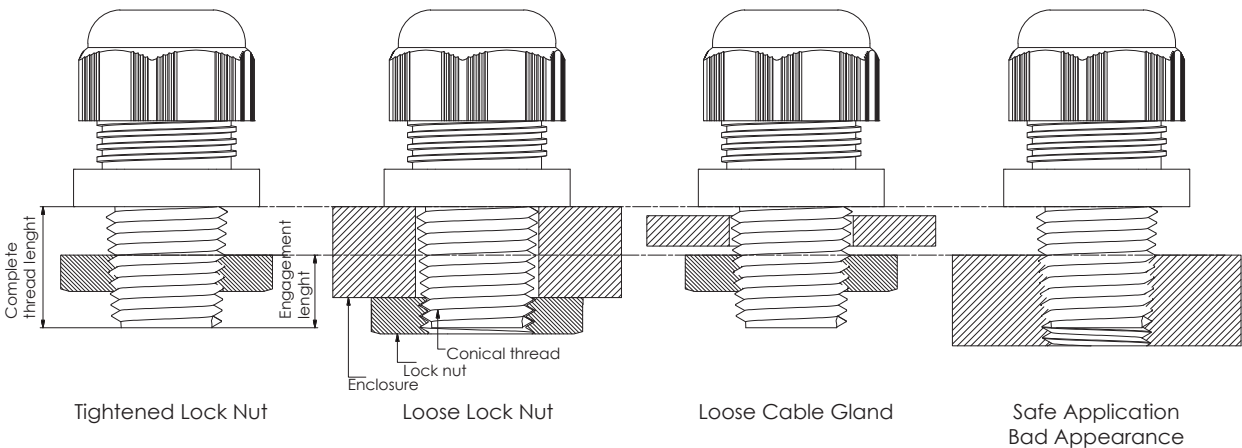

Thread standard	ANSI B1.20.1
Thread name	National Pipe Threads
Thread definition	NPT is an US Standard for "Tapered Threads" used in threaded pipes and fittings. The thread can provide an effective seal for liquids, gases, hydraulic, fluids and steam. They are used generally for steel, brass, cast-iron, PTFE, PVC, PA materials.
Other Appellations	MPT : Male Pipe Threads FPT : Female Pipe Threads
Applications	The NPT threads are always used for male and female pipe / fitting joints. Regarding the conicity of the thread they are not suitable for lock-nut applications.
"Cable Glands" and "Electrical Fitting" applications	The NPT threaded cable glands or male threaded electrical fittings as reducers, blind stops etc must used a NPT female threaded enclosures or cabinets. The usage of lock nuts for NPT threads is not a recommended application. According the relevant standard, the male and female threads have a defined engagement length. When we use a lock nut (even if is NPT threaded), we know that this one will be blocked, after the defined length portion of the male thread. In result we can not be sure that this blocking distance will be suitable for the wall thickness of the enclosure or cabinet. If we are using an equivalent parallel thread lock nut the result will be worst because the male and female thread, will not be in complete contact.

Plug Assembling Instruction

Assembling with lock nut on **non threaded** enclosure

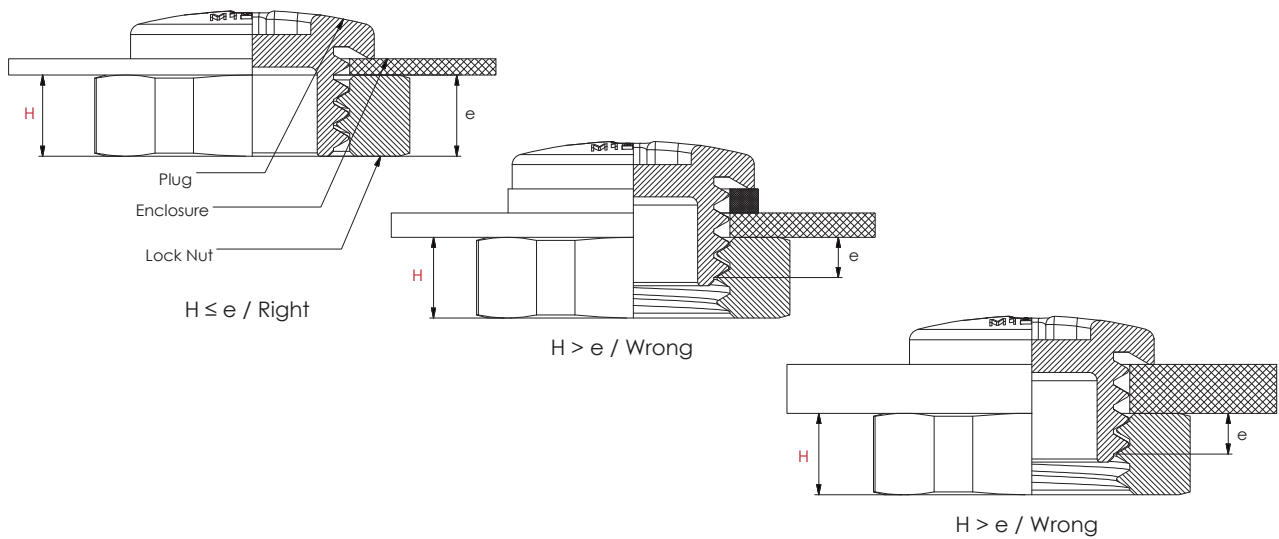

Relevant Lock Nut Thickness		
Size		H (±0,5 mm)
M12 to M16	Pg 7 to Pg 11	5,0
M20 to M25	Pg 13,5 to Pg 16	6,0
M32 to M40	Pg 21 to Pg 29	7,0
M50 to M63	Pg 36 to Pg 42	8,0



Assembling with lock nut on **threaded** enclosure

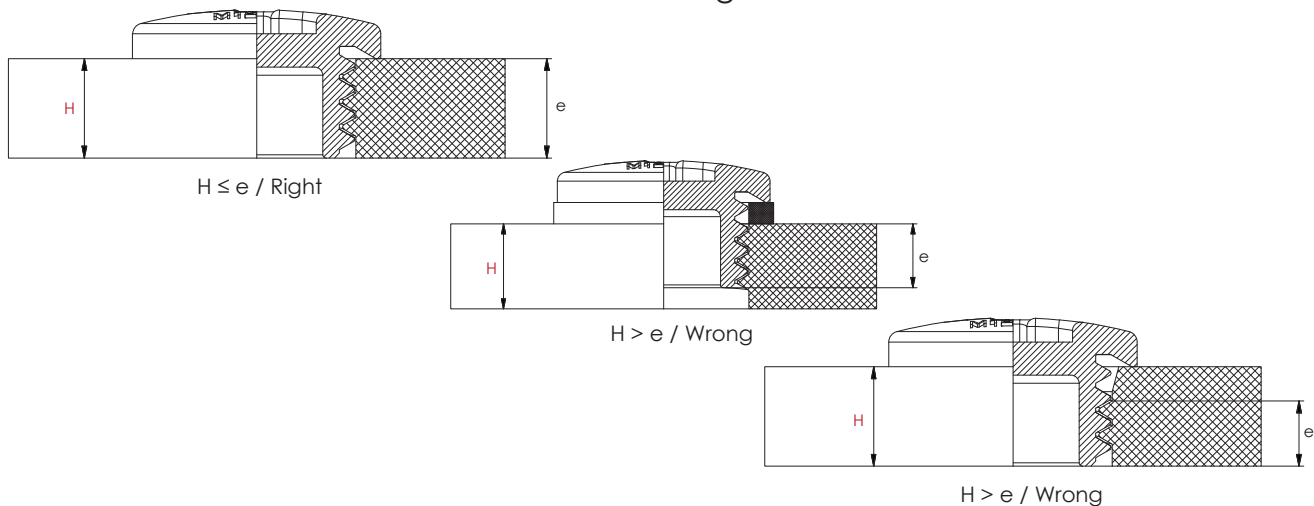

Complementary Instructions:

- The engaged thread length "e" must be equal or longer than relevant lock nut thickness "H"
- The thread dimensions and tolerances on threaded enclosures must be convenient with the relevant thread standard.
- Firstly, the blind stop must be mounted to the enclosure.
- The blind stop or the lock nut must be tightened according to torque indicated on the instruction chart.
- As much as possible double tool have to be used for non threaded enclosures.(Screw driver+wrench)

Part Number INDEX

B-	
B-RA ...	234-237
B-RB ...	230-233
B-RM ...	238-241
B-RN ...	242-245
B-TS ... C	246-247
B-TS ... M	246-247
B-TS ... N	248-249
B-TS ... P	246-247
BB	
BBFB- ...	102-103
BBFB- ... 45	104-105
BBFB- ... 90	106-107
BBFB- ... CH	110-111
BBFB- ... F	108-109
BBFM- ...	102-103
BBFM- ... 45	104-105
BBFM- ... 90	106-107
BBFM- ... CH	110-111
BBFM- ... F	108-109
BBFN- ...	102-103
BBFN- ... 45	104-105
BBFN- ... 90	106-107
BBFN- ... F	108-109
BBOS- ...	28-29
BBS- ... (Y+)	116
BC	
BCF- ...	96
BCM- ...	96
BD	
BDP- ...	277
BDPX- ...	280-281
BDRL- ...	80-81, 200-201
BDRLN- ...	80-81, 200-201
BDRV- ...	200-201
BDSM-08 --- BDSM-13	30-31
BDSM-0S, BDSM-01 --- BDSM-05	34
BDSP- ...	34
BE	
BEX- ...	8-9, 28-29, 54-55
BF	
BFL- ...	286
BFSP- ...	10-13
BFSR- ...	10-13
BFSW- ...	282-283
BI	
BI- ...	4-7
BISP- ...	10-13
BL	
BL- ...	286
BLMN- ...	287
BLN- ...	287
BM	
BM- ...	4-7
BM-EN- ...	4-7
BM-SX ...	252-253
BM-SX ... (...x...)	262-263
BM-X ...	252-253
BM-X ... (...x...)	262-263
BMBC- ...	20-23
BMBCRJ- ...	35
BMBCSP- ...	32
BMBCVG- ...	76-77
BMBD- ...	20-23
BMBDSP- ...	32
BMBE- ...	20-23
BMBERJ- ...	35
BMBL- ...	288-289
BMBLS- ...	288-289
BMBS- ... (A)	117
BMBS- ... (Y+)	116
BMCRCR- ...	291
BMDL- ...	74-75
BMEFGX- ...	88-89
BMEL- ...	290
BMELS- ...	290
BMEM- ...	44-45
BMEM- ... (...T)	52-53
BMEM-E ...	48-49
BMEMSP- ...	56-57
BMEN- ...	44-45

BMEOS- ... (T)	54-55
BMEP ...	291
BMET ...	285
BMFGST- ...	86-87
BMFGT- ...	86-89
BMFGX- ...	86-87
BMHFX- ...	90-91
BML- ...	286
BMNGB- ...	33
BMNGC- ...	33
BMOS- ...	8-9
BMPL- ...	118
BMRJ- ...	15
BMSC- ...	24-27
BMSD- ...	24-27
BMSE- ...	24-27
BMSH ...	291
BMSP- ...	10-13
BMSSW- ...	112
BMSW- ...	282-283
BMTW- ...	284
BMVG- ...	70-71

BN	
BN-LX ...	252-253
BN-SX ...	252-253
BN-X ...	252-253
BNBC- ...	20-23
BNBS- ... (A)	117
BNEL- ...	290
BNELS- ...	290
BNEM- ...	44-45
BNEM- ... (...T)	52-53
BNET ...	285
BNLN- ...	288-289
BNLNS- ...	288-289
BNSC- ...	24-27
BNSD- ...	24-27
BNSPA- ...	10-13
BNSPB- ...	10-13
BNSPC- ...	10-13
BNSPD- ...	10-13
BNSW- ...	282-283

BP	
BPDRP- ...	74-75
BPF- ...	4-7
BPFL- ...	288-289
BPFLS- ...	288-289
BPFR- ...	4-7
BPL- ...	286

BR	
BRC90F- ...	98
BRC90R- ...	101
BRC- ...	99
BRCF- ...	97
BRCM- ...	100

BS	
BS- ...	4-7
BSBC- ...	20-23
BSBCRJ- ...	35
BSBCSP- ...	32
BSBCVG- ...	76-77
BSBD- ...	20-23
BSBDSP- ...	32
BSBE- ...	20-23
BSBERJ- ...	35
BSEL- ...	290
BSELS- ...	290
BSEM- ...	44-45
BSEM- ... (...T)	52-53
BSEN- ...	44-45
BSL- ...	288-289
BSLS- ...	288-289
BSP- ...	4-7
BSPA- ...	4-7
BSPB- ...	4-7
BSPC- ...	4-7
BSPD- ...	4-7
BSP- ...	118
BSR- ...	4-7
BSRJ- ...	15

BSRP- ...	10-13
BSSC- ...	24-27
BSSD- ...	24-27
BSSF- ...	24-27
BSSP- ...	10-13
BSSW- ...	282-283
BSVG- ...	70-71

EB

EBLN ...	224-225
EBLQ ...	222-223
EBLS ...	220-221
EBM ...	204-207
EBM ... (Fx...)	208-211
EBMC ...	226-227
EBMS ...	212-215
EBS ...	182-183
EBU ...	186-189
EBU ... (Fx...)	190-191
EBUOXSM	182-183

EG

EG- ...	14
EGR- ...	14

EH

EHBM- ...	256-259
EHBN- ...	256-259

HB

HBAVP- ...	78-79
HBBVP- ...	78-79
HBBVP-X ...	198-199
HBBVPP- ...	78-79
HBBVPX- ...	78-79
HBVPA- ...	72-73
HBVPB- ...	72-73
HBVPD- ...	72-73
HBVPE- ...	72-73
HBVPF- ...	72-73
HBVPX- ...	72-73
HBVQ- ...	72-73

HI

HIBM- ...	254-255
HIBM- ... (...x...)	264-265
HIBN- ...	254-255
HITN- ...	270-271
HITP- ...	270-271

IB

IB-RA ... M ... M	122-123
IB-RA ... P ... M	120-121
IB-RA ... P ... P	122-123
IB-RB ... M ... M	119
IB-RB ... M ... P	120-121
IB-RB ... P ... M	120-121
IB-RB ... P ... P	119
IBDRV- ...	80-81

IT

ITSH- ...	124
ITSR- ...	125

KB

KBA ...	160-163
KBA ... -LSK	164-167
KBA ... -M	132-135
KBAO ...	156-159
KBAU ...	152-155
KBC ...	176-179
KBC ... -M	136-139
KBCO ...	172-175
KBCTA ...	180-181
KBCTA ... -M	140-141
KBCTN ...	194-195
KBCTN ... -M	148-149
KBCU ...	168-171
KBET ...	36-37
KBU ...	192-193

MB

MB-TS ...	248-249
MBAVP- ...	78-79
MBBVP- ...	78-79
MBBVP-X ...	198-199
MBBVPP- ...	78-79
MBBVPX- ...	78-79
MBVPA- ...	72-73
MBVPB- ...	72-73

MBVPD- ...	72-73
MBVPE- ...	72-73
MBVPF- ...	72-73
MBVPG- ...	72-73
MBVPGQ- ...	72-73
MBVPX- ...	72-73
MBVQ- ...	72-73

MD

MDS- ...	275
----------	-----

MF

MFS- ...	276
----------	-----

MK

MKBU ...	144-147
----------	---------

MM

MMS- ...	277
----------	-----

MS

MS- ...	274
---------	-----

NB

NB-TS ...	246-247
-----------	---------

PD

PDS- ...	275
----------	-----

QF

QF- ...	16-17
QFR- ...	16-17
QFVR- ...	16-17

RB

R-BM- ...	66-67
R-BMBC- ...	62-63
R-BMBE- ...	62-63
R-BMEM- ... (...T)	64-65
R-BU ...	60-61

SB

SBAVP- ...	78-79
SBBVP- ...	78-79
SBBVP-X ...	198-199
SBBVPP- ...	78-79
SBBVPX- ...	78-79
SBVPA- ...	72-73
SBVPB- ...	72-73
SBVPD- ...	72-73
SBVPE- ...	72-73
SBVPF- ...	72-73
SBVPX- ...	72-73
SBVQ- ...	72-73

SV

SV ...	216-217
--------	---------

TP

TP- ...	268-269
---------	---------

UH

UHBAVP- ...	78-79
UHBBVP- ...	78-79
UHBBVP-X ...	198-199
UHBBVPP- ...	78-79
UHBBVPX- ...	78-79
UHBVPA- ...	72-73
UHBVPB- ...	72-73
UHBVPD- ...	72-73
UHBVPE- ...	72-73
UHBVPF- ...	72-73
UHBVPX- ...	72-73
UHBVQ- ...	72-73